

# A Review on Space Time Coding Techniques

<sup>1</sup>Ravi Kurariya

Research Scholar, M. Tech.  
Digital Communication, SRIT, Jabalpur

<sup>2</sup>Rashika Gupta

Assistant Professor,  
Dept. of ECE, SRIT, Jabalpur

<sup>3</sup>Ravimohan

Professor & H.O.D.  
Dept. of ECE, SRIT, Jabalpur

**Abstract** - In this paper, we surveyed the basic concepts of one of the most emerging field of space-time coding for wireless communication systems. Spatial & the capacity of the Multiple Input Multiple Output (MIMO) wireless channel in Rayleigh fading are studied & literature survey of them are discussed. The structure of the signal enables us to exploit diversity in the spatial & temporal dimensions in order to obtain improved bit error performance & higher data rates without bandwidth expansion. Thus it is observed that transmit diversity plays an integral role in space-time code design. A brief survey of such existing communication techniques are discussed in this paper. Various encoding schemes & receiver architectures for space time coding are also discussed along with their comparison. This paper also explores the research avenues in design of perfect (NxN). Alamouti space-time codes which have been introduced as the class of linear dispersion space-time codes having full rate, non-vanishing determinant, a signal constellation isomorphic to either the rectangular or hexagonal lattices & uniform average transmitted energy per antenna.

**Keywords** — MIMO, spatial diversity, perfect code, Alamouti STBC, Rayleigh Fading.

## I. INTRODUCTION

In a MIMO system, Multi-Element Antenna array structures are installed at both the transmitter & receiver. From a communications engineering aspect, the huddle is to design the signals are to be sent by the transmit array & the algorithms for processing these signals at the receive array, so that the quality of the transmission (i.e., bit error rate) & its data rate are performance should be improved. This gain can be further used to provide increased reliability, lower power requirements (per transmit antenna) or higher composite data rates (either higher rates per user or more users per link). The benefits offered by MIMO technology is it can be deployed without the need for additional spectral resources.

Historically, work on transmit diversity techniques started as early as 1990s. In [4], the authors consider transmitting delayed copies of the information-bearing signal on each antenna in order to obtain a diversity gain at the receiver. A more generalized approach presented in [5] proposes the use of a bank of linear time invariant precoding filters at the transmitter, combined with Maximum Likelihood (ML) detection at the receiver, to achieve the desired diversity gain.

## II. SPATIAL DIVERSITY TECHNIQUES

The wireless environment presents a challenging communications problem because of the possibly time-, frequency- & spatially-varying degradations caused by signal fading. As we shall see, these impairments are not

necessarily harmful. Under certain conditions it is possible to take advantage of the variations in the channel's responses to improve the received Signal-to-Noise Ratio (SNR). For instance, suppose that the channel is such that two identical signals transmitted in parallel over two distinct frequency subchannels, experience independent fading effects. The receiver can then obtain two copies of the desired signal, & the probability that both are severely degraded is lower than in the case where only one observation is available. Thus a better overall estimate may be recovered by combining these together in some manner. The idea of obtaining a number of different copies of the same signal is called diversity. Such techniques provide a powerful toolset for achieving reliable transmission over fading channels. Although there are a number of means by which signal diversity can be obtained, the desired end remains the same: Enable the receiver to recover a more robust replica of the transmitted signal by combining a number of independently faded copies. Thus, diversity techniques can only be applied in cases & domains where the channel is sufficiently selective.

In this paper main focus is on spatial diversity, i.e., which are achieved from using MEA arrays. However, there are also four other kinds of diversity that are of current interest in the literature: frequency diversity, time diversity, polarization diversity, Modal or pattern diversity.

MEA arrays are used in wireless communications to improve system performance at the expense of processing complexity at the transmitter, receiver, or both. This section illustrates how the signals transmitted using MEAs can be designed & processed to provide a diversity advantage, i.e., improved SNR & hence bit error performance at the receiver. In the case of the MIMO channel, where MEAs are used at both the transmitter & receiver, are used for increased capacity.

### A. Receive only Diversity

Research in spatial diversity focused initially on receiver techniques, motivated by the goal of mitigating degradations in the signal caused by multipath propagation. Under the assumption that the paths taken by each of the copies result in statistically independent fading effects, we can conclude that they are unlikely to all be in a deep fade, i.e., strongly distorted, simultaneously. Thus an improved signal may be obtained by forming a weighted combination of the received copies.

The success of receive diversity in improving the performance of wireless communication systems led to the wide deployment of multiple element antenna arrays, particularly at base stations where hardware size & cost are less important considerations. There they could be used to

enhance the uplink channel from the subscriber unit to the base station. To achieve similar benefits in the downlink channel, while not requiring multiple element arrays at the subscriber unit, transmit diversity is required.

*B. Transmit Only Diversity*

Because of the physical size of the relevant antennas as well as restrictions on the processing power available at subscriber terminals, receive diversity was appropriate for improving signal quality only at the base station, i.e., in the uplink. Interest in transmit diversity techniques arose in an attempt to realize similar performance benefits in the downlink, while displacing the additional processing complexity & the physical burden of the MEA from subscriber units to the basestation.

Transmit diversity is inherently a more difficult problem than receive diversity. In the case of receive diversity we obtain copies of the signal that are assumed to have undergone independent fading. The task at hand is to combine them optimally to recover the original transmitted signal. One fundamental difference between such systems & those employing transmit diversity is that in the latter case the signals are already combined when they reach the receiver. Even assuming that the receiver has perfect CSI, separating this mixture of signals in an optimal manner is a great challenge.

*C. Combined Transmit- Receive Diversity*

MEAs can also be used at both the transmit& receive arrays, in conjunction with STBCs of block length  $L = N$ , to provide a diversity advantage of up to  $NM$  over  $\circ$ at quasi-static fading channels. Spatial diversity at the transmitter may be converted into selectivity in the time or frequency domains. When using MEAs at both the transmit& receive arrays, it is not necessary to add redundancy to the transmitted signal matrix in order to detect the symbols. Different signals can be recovered at the receiver using standard processing techniques based on linear algebra. This increase in the communication rate is known as a spatial multiplexing gain. The most popular of spatial multiplexing strategies is known as the Bell Labs layered Space-Time (BLAST) transmission scheme.

Table 1 summarizes the maximum diversity advantage & rates that can be achieved in the various spatial diversity scenarios.

Spatial diversity scenario	Maximum diversity advantage	Maximum rate
No diversity	1	1 sym/s/Hz
Receive diversity	$M$	1 sym/s/Hz
Transmit diversity	$N$	1 sym/s/Hz
Transmit and receive diversity	$NM$	$\min\{M, N\}$ sym/s/Hz

Table 1: Summary of achievable performance for different spatial diversity scenarios in a quasi-static Rayleigh fading.

III. SPACE TIME CODES

The term Space-Time Code (STC) was originally coined in 1998 by Tarokh et al. to describe a new two-dimensional way of encoding & decoding signals transmitted over wireless fading channels using multiple transmit antennas [3]. In two key papers, the authors laid down the theories of the SpaceTime Trellis Code (STTC) [3] & the Space-Time Block

Code (STBC) [4] for independent Rayleigh fading channels. A number of other schemes employing multiple antenna arrays were also developed at about the same time, e.g., the simple & popular Alamouti STBC [5], a transmit diversity scheme using pilot symbol-assisted modulation [6] & the Bell Labs layered Space-Time (BLAST) multiplexing framework [7]. Since then, the term STC has been used more generally to refer to transmit diversity techniques in which the transmitted signals & corresponding receiver are designed to exploit spatial diversity. A more detailed overview of some fundamental techniques, along with a brief survey of core contributions to the field is discussed in this paper.

Figure1 depicts the system model of a space-time transmitter which starts from the source, which generates Kbit data vectors.

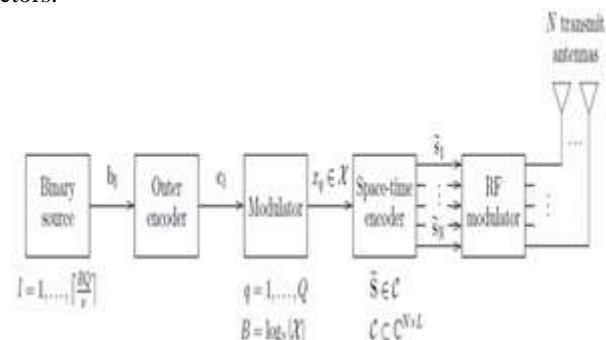

Figure 1: System model of generic space-time transmitter.

Consider  $[BQ/V]$  vectors at a time. The outer encoder represents a traditional error correcting code of rate  $K/V$ . Therefore it produces from this input  $[BQ/V]$  V-bit codewords. The modulator is a bit-to- Symbol mapper that outputs  $Q$  symbols from finite & generally complex alphabet, where the modulation order is  $B = \log_2|X|$ .

The next step in our generic system is the space-time encoder. It transforms the  $Q$  symbols  $X_q$  into  $N$  vectors of complex signals to be transmitted from the  $N$  antennas. Each is of length  $L$ , which is the number of symbol periods that it takes to complete the transmission. These vectors form the rows of space-time signal matrix. The overall rate of the code is therefore  $BQ/ L$ , where the first term arises from the outer code, the second from the modulation order, & the third from the inner space-time code.

Figure 2 depicts the system model of a space-time receiver. As is typical in transmission systems, the receiver blocks perform the inverse operations of their transmitter-side counterparts. We note that the quantizer or (symbol) decision device is shown in two places as a dotted block. It would typically be placed before the demodulator, except in the case of a detection approach making use of soft-decision information, e.g., the soft-decision Viterbi algorithm applied to a STTC. The space-time detector may also make use of feedback from the output of the quantizer, as in the V-BLAST receiver.

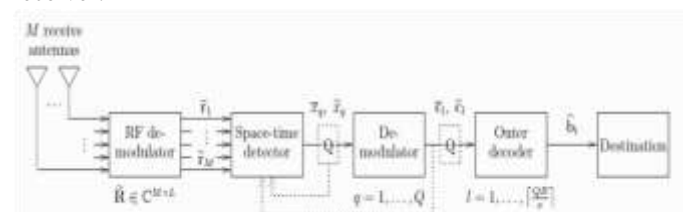

Figure 2: System model of generic space-time receiver.

IV. CLASSIFICATION OF SPACE TIME CODES

In this section, the aim is to highlight important developments that have been reported in the body of literature on space-time coding. To assist in presenting a logically structured discussion, the existing works have been divided into four major directions of current research interest as summarized by the classification tree shown.

The four leaf nodes represent areas that have produced interesting recent publications. Two other related fields of study are also shown in the diagram: Concatenated codes, which involve wrapping a generally one-dimensional outer code around an inner space-time technique to improve its performance, & Multi-User Detection (MUD).

There are various approaches in coding structures, including space-time block codes (STBC), space-time trellis codes (STTC), space-time turbo trellis codes & layered space-time (LST) codes. A central issue in all these schemes is the exploitation of multipath effects in order to achieve high spectral efficiencies & performance gains. Among the various criteria applied in the design & evaluation of space-time codes, maximizing diversity gain or achievable rate (spatial multiplexing gain) are popular.

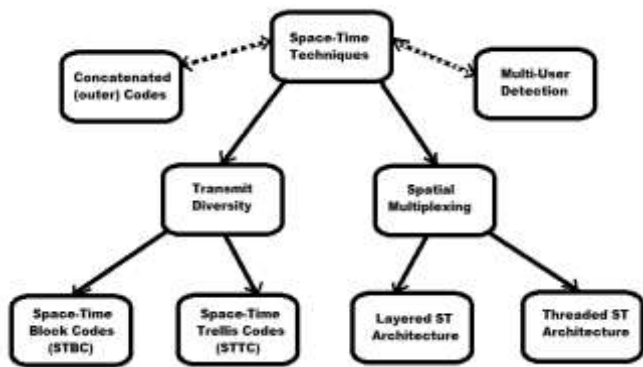

Figure 3: Classification of space-time coding techniques

A. Space Time Block Codes

There are three key STBCs which are widely used as performance benchmarks & form the foundation of insightful new analytical results. The first is the Alamouti code. Next, is an extended version of Alamouti's work, which accommodates larger numbers of transmit antennas, proposed by Tarokh et al. under the name of orthogonal designs. Finally we take a look at the linear dispersion codes of Hassibi et al., which address the capacity limitations of both of these codes & also support arbitrary numbers of transmit antennas.

1) Alamouti block code

The Alamouti code is the first & probably most well-known STBC. It is designed from the perspective of diversity gain, with the goal of enabling a multiple antenna transmission scheme to achieve the same performance benefits as the optimal SNR multiple antenna MRC receivers. The Alamouti block code succeeds in realizing this desired diversity gain, in the case where there are two transmit antennas, by arranging

the symbols & their complex conjugates in a special 2 x 2 matrix.

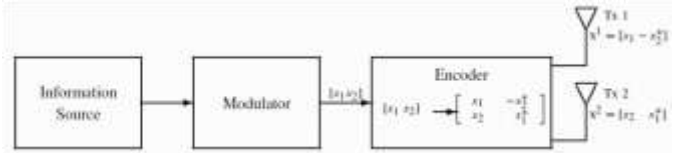

Figure 4: A block diagram of the Alamouti space-time encoder

Figure 4 shows the block diagram of the Alamouti space-time encoder. Let us assume that an *M*-ary modulation scheme is used. In the Alamouti space-time encoder, each group of *m* information bits is first modulated, where  $m = \log_2 M$ . Then, the encoder takes a block of two modulated symbols  $x_1$  &  $x_2$  in each encoding operation & maps them to the transmit antennas according to a code matrix given by –

$$X = \begin{bmatrix} x_1 & -x_2^* \\ x_2 & x_1^* \end{bmatrix}$$

The encoder outputs are transmitted in two consecutive transmission periods from two transmit antennas. During the first transmission period, two signals  $x_1$  &  $x_2$  are transmitted simultaneously from antenna one & antenna two, respectively. The encoding is done in both the space & time domains.

$$x^1 = [x_1, -x_2^*]$$

$$x^2 = [x_2, x_1^*]$$

The key feature of the Alamouti scheme is that the transmit sequences from the two transmit antennas are orthogonal, since the inner product of the sequences  $x_1$  &  $x_2$  is zero, i.e.

$$x^1 \cdot x^2 = x_1 x_2^* - x_2^* x_1 = 0$$

Assume that one receive antenna is used at the receiver. The block diagram of the receiver for the Alamouti scheme is shown in Figure 5. The fading channel coefficients from the first & second transmit antennas to the receive antenna at time *t* are denoted by  $h_1(t)$  &  $h_2(t)$ , respectively.

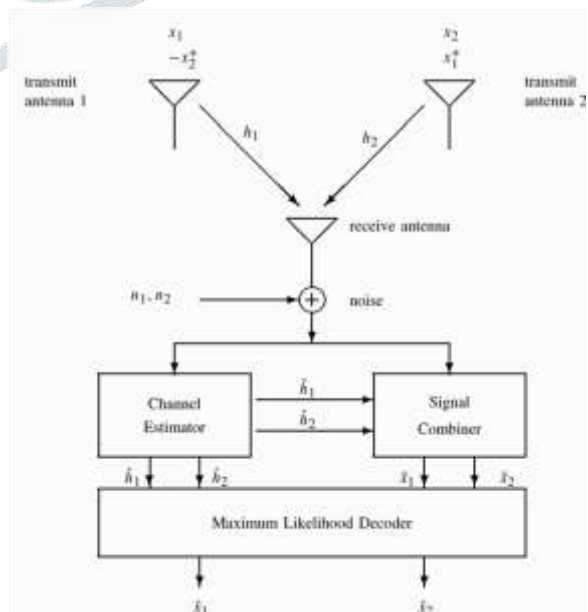



Figure 5 : Receiver for the Alamouti scheme

At the receive antenna, the received signals over two consecutive symbol periods, denoted by  $r_1$  &  $r_2$  for time  $t$  &  $t + T$ , respectively, can be expressed as:

$$r_1 = h_1x_1 + h_2x_2 + n_1$$

$$r_2 = -h_1x_2^* + h_2x_1^* + n_2$$

The Alamouti scheme can be applied for a system with two transmits &  $n_r$  receive antennas. The encoding & transmission for this configuration is identical to the case of a single receive antenna.

2) Alamouti block code with orthogonal designs

The Alamouti scheme achieves the full diversity with a very simple maximum-likelihood decoding algorithm. The key feature of the scheme is orthogonality between the sequences generated by the two transmit antennas. This scheme was generalized to an arbitrary number of transmit antennas by applying the theory of *orthogonal designs*. The generalized schemes are referred to as *space-time block codes* (STBCs) [5]. The space-time block codes can achieve the full transmit diversity specified by the number of the transmit antennas  $nT$ , while allowing a very simple maximum-likelihood decoding algorithm, based only on linear processing of the received signals [5].

In the space-time block code, the number of symbols the encoder takes as its input in each encoding operation is  $k$ . The number of transmission periods required to transmit the space-time coded symbols through the multiple transmit antennas is  $p$ .

The *rate* of a space-time block code is defined as the ratio between the number of symbols the encoder takes as its input & the number of space-time coded symbols transmitted from each antenna. It is given by;

$$R = k/p$$

The spectral efficiency of the space-time block code is given by;

$$\eta = \frac{r_b}{B} = \frac{r_s m R}{r_s} = \frac{km}{p} \text{ bits/s/Hz}$$

Where  $r_b$  &  $r_s$  are the bit & symbol rate, respectively, &  $B$  is the bandwidth.

The entries of the transmission matrix  $\mathbf{X}$  are linear combinations of the  $k$  modulated symbols  $x_1, x_2, \dots, x_k$  & their conjugates  $x_1^*, x_2^*, \dots, x_k^*$ . In order to achieve the full transmit diversity of  $nT$ , the transmission matrix  $\mathbf{X}$  is constructed based on orthogonal designs such that [3]

$$\mathbf{X} \cdot \mathbf{X}^H = c(|x_1|^2 + |x_2|^2 + \dots + |x_k|^2) \mathbf{I}_{nT}$$

In general, if an  $nT \times p$  real transmission matrix  $\mathbf{X}_{nT}$  with variables  $x_1, x_2, \dots, x_k$  satisfies

$$\mathbf{X}_{nT} \cdot \mathbf{X}_{nT}^T = c(|x_1|^2 + |x_2|^2 + \dots + |x_k|^2) \mathbf{I}_{nT}$$

The Alamouti scheme can be regarded as a space-time block code with complex signals for two transmit antennas. The transmission matrix is represented by

$$\mathbf{X}_2^c = \begin{bmatrix} x_1 & -x_2^* \\ x_2 & x_1^* \end{bmatrix}$$

This scheme provides the full diversity of 2 & the full rate of 1. The Alamouti scheme is unique in that it is the only spacetime block code with an  $n_t \times n_r$  complex transmission matrix to achieve the full rate [5].

3) Linear dispersion codes

To realize rates higher than 1 sym/s/Hz using space-time block coded transmission, Hassibi et al. studied the effective capacity of codes based on orthogonal designs [8]. The authors show that it is not possible for these codes to achieve the maximum capacity supported by the channel. They then develop a new class of block codes designed to maximize the mutual information between the transmitted & received signals. The resulting designs are called linear dispersion codes. The proposed codes can be defined in terms of space-time modulation using a set of  $2Q$  dispersion matrices  $\mathbf{A}_q; \mathbf{B}_q$

$\in \mathbb{C}^{N \times L}$ :

$$\tilde{\mathbf{S}} = \sum_{q=1}^Q (x_{Rq} \mathbf{A}_q + jx_{Iq} \mathbf{B}_q),$$

What differentiates the linear dispersion code from others is the approach taken to decoding. It is based on detecting  $2Q$  dimensional, rather than  $N$  dimensional, vectors of transmitted symbols. A key step in the development of this algorithm is the transformation of the received signal matrix

$\tilde{\mathbf{R}} = \mathbf{H}\tilde{\mathbf{S}} + \tilde{\mathbf{N}}$  into the following form:

$$\tilde{\mathbf{R}} = \mathbf{H} \sum_{q=1}^Q (x_{Rq} \mathbf{A}_q + jx_{Iq} \mathbf{B}_q) + \tilde{\mathbf{N}}$$

The main drawback of linear dispersion codes is that good designs are not known to follow systematic or algebraic rules. Choosing the dispersion matrices involves choosing a target block rate  $Q$  given  $M, N$  &  $L$ , & then optimizing the effective ergodic capacity subject to a power constraint.

In general, it is shown that linear dispersion codes optimized first for spatial multiplexing gain & then for diversity gain outperform STBCs based on orthogonal designs & VBLAST over a wide range of SNRs & target rates.

B. Space Time Trellis Codes

Space-time block codes can achieve a maximum possible diversity advantage with a simple decoding algorithm. It is very attractive because of its simplicity. However, no coding gain can be provided by space-time block codes, while non-full rate space-time block codes can introduce bandwidth expansion. In this section, a joint design of error control coding, modulation, transmit & receive diversity is considered to develop an effective signaling scheme called the space-time trellis codes (STTC), which is able to combat the effects of fading.

STTC was first introduced by Tarokh, Seshadri & Calderbank [3]. It can simultaneously offer a substantial coding gain, spectral efficiency, & diversity improvement on flat fading

channels. For space-time trellis codes, the encoder maps binary data to modulation symbols, where the mapping function is described by a trellis diagram.

Consider an encoder of space-time trellis coded  $M$ -PSK modulation with  $n_T$  transmit antennas as shown in Figure 6. The input message stream, denoted by  $\mathbf{c}$ , is given by;  $\mathbf{c} = (c_0, c_1, c_2, \dots, c_t, \dots)$

The encoder maps the input sequence into an  $M$ -PSK modulated signal sequence, given by  $\mathbf{x} = (x_0, x_1, x_2, \dots, x_t, \dots)$

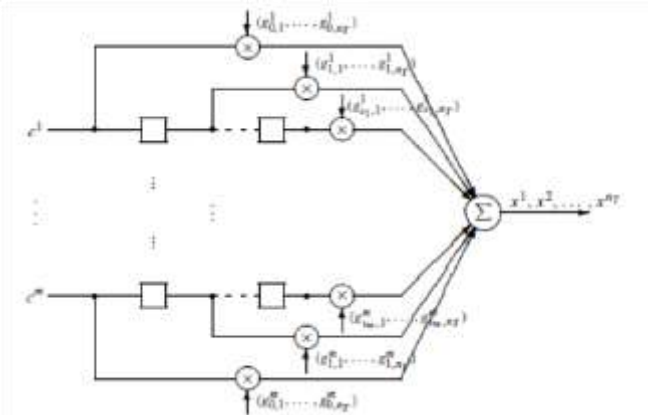

Figure 6 : Encoder for Trellis codes

The encoder output at time  $t$  for transmit antenna  $i$ , denoted by  $x_{it}$ , can be computed as –

$$x_i^t = \sum_{k=1}^m \sum_{j=0}^{v_k} g_{j,i}^k c_{t-j}^k \pmod{M}, \quad i = 1, 2, \dots, n_T$$

The space-time trellis coded  $M$ -PSK can achieve a bandwidth efficiency of  $m$  bits/s/Hz. The total number of states for the trellis encoder is  $2^v$ . The total memory order of the encoder, denoted by  $v$ , is given by

$$v = \sum_{k=1}^m v_k$$

In generator polynomial format,

$$\mathbf{x}^t(D) = \begin{bmatrix} c^1(D) & c^2(D) \end{bmatrix} \begin{bmatrix} G_1^1(D) \\ G_1^2(D) \end{bmatrix} \pmod{4}$$

Assuming generator sequences of a 4-state space-time trellis coded QPSK scheme with 2 transmit antennas as-

$$\mathbf{g}^1 = \{(02), (20)\}$$

$$\mathbf{g}^2 = \{(01), (10)\}$$

The trellis structure for the code is shown in Figure 7. The trellis consists of  $2^v = 4$  states, represented by state nodes. The encoder takes  $m = 2$  bits at input &  $2m = 4$  branches leave from each state corresponding to four different input patterns.

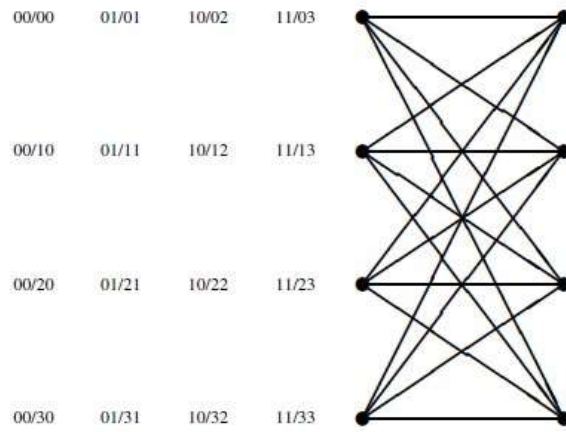

Figure 7: Trellis structure

Assume that the input sequence is :

$$\mathbf{c} = (10, 01, 11, 00, 01, \dots)$$

The output sequence generated by the space-time trellis encoder is given by:

$$\mathbf{x} = (02, 21, 13, 30, 01, \dots)$$

The decoder employs the Viterbi algorithm to perform maximum likelihood decoding. Assuming that perfect CSI is available at the receiver, for a branch labeled by  $(x_1t, x_2t, \dots, x_{n_T}t)$ , the branch metric is computed as the squared Euclidean distance between the hypothesized received symbols & the actual received signals as-

$$\sum_{j=1}^{n_R} \left| r_t^j - \sum_{i=1}^{n_T} h_{j,i}^t x_{i,t}^j \right|^2$$

The Viterbi algorithm selects the path with the minimum path metric as the decoded sequence.

The STTC encoder structure does not guarantee geometrical uniformity of the code [9]. Therefore, the search is conducted over all possible pairs of paths in the code trellis.

### C.Space Time Turbo Trellis Codes

Space-time coding techniques which combine the coding gain benefits of turbo coding with the diversity advantage of spacetime coding & the bandwidth efficiency of coded modulation are called as *space-time turbo trellis code* (ST turbo TC). They can be constructed by alternate parity symbol puncturing & applying symbol interleaving [10] or by information puncturing & bit interleaving.

Figure 8 shows the encoder structure of a ST turbo TC with  $n_T$  transmit antennas, consisting of two recursive STTC encoders, linked by a symbol interleaver.

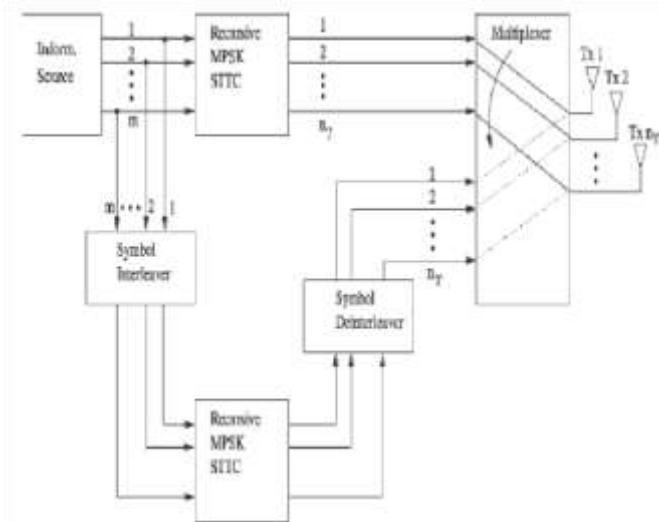

Figure 8: Encoder for ST trellis coded modulation

The upper recursive STTC encoder maps the input sequence into  $M$ -PSK symbols, which are then interleaved by a symbol interleaver. The lower encoder produces  $nT$  streams of  $L$  MPSK symbols. Each stream is deinterleaved before puncturing & multiplexing. The deinterleaved stream can be represented. The streams of symbols generated by the upper & lower encoders,  $x_1$  &  $x_2$ , are alternately punctured.

1) V-BLAST Scheme

An uncoded LST structure, known as *vertical layered spacetime* (VLST) or *vertical Bell Laboratories layered spacetime* (VBLAST) scheme [11], is illustrated in Figure 10. In this architecture  $Q = NL$  symbols are transmitted over  $L$  symbol periods, resulting in a rate of  $N$  sym/s/Hz as desired. Since the signals transmitted during each symbol period are independent, i.e., there is no temporal code structure, we can consider detection in each time step separately. Detection is done by a strategy known as successive interference cancellation, whereby each of the  $N$  symbols is detected in sequence & the hard-decision produced at the end of each loop is used to cancel out interference caused by the detected symbol from the residual observation vector.

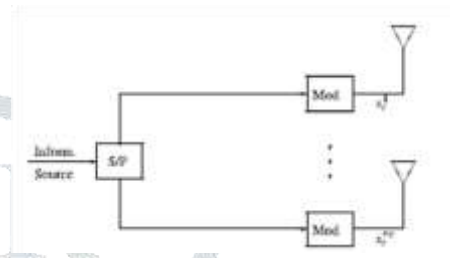

Figure 10: Vertically layered space-time architecture

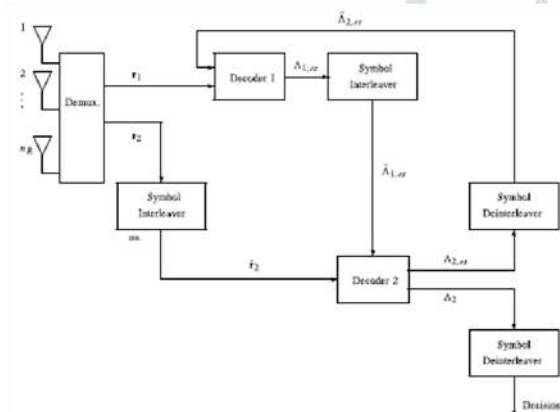

Figure 9: Turbo TC decoder with parity symbol puncturing

The decoder block diagram is shown in Figure 9. The decoding process is similar to the binary turbo code except that the symbol probability is used as the extrinsic information rather than the bit probability. The MAP decoding algorithm for non-binary trellises is called symbol-by-symbol MAP algorithm. The MAP decoder computes the (LLR) loglikelihood ratio of each group of information.

D. Layered Space Time Codes

These systems are designed to optimize spatial multiplexing rather than diversity gain with  $M > N$  receive antennas & therefore achieve rates of  $N$  sym/s/Hz by transmitting independent sub-streams from each antenna. Some diversity gain is available via diversity combining at the receiver. Also some coding gain can be obtained by applying 1 dimensional outer code to each of the sub-streams. There are three main approaches: uncoded V-BLAST, coded (Horizontal) HBLAST, & coded (Diagonal) D-BLAST.

There are three key tasks performed at the receiver: ordering, nulling & cancellation. The ordering operation involves selecting the order of detection of the symbols at each time step. The nulling step is analogous to the feed forward filter of a generalized Decision-Feedback Equalizer (DFE). It produces the best estimate of a particular transmitted symbol, given the presence of interference & noise. This step can be implemented using zero-forcing or MMSE linear detectors. The purpose of the cancellation step is to improve the performance of subsequent nulling loops by removing interference caused by the most recently decoded symbol. It is non-linear since it is based on the hard-decision or quantized symbol.

$$\vec{S} = \begin{bmatrix} \xi_1 & \dots & \xi_1 & \dots & \dots & \dots & \dots & 0 \\ 0 & \xi_1^{*2} & \dots & \dots & \dots & \dots & \dots & \vdots \\ \vdots & \vdots & \ddots & \dots & \dots & \dots & \dots & 0 \\ 0 & \dots & \dots & 0 & \dots & \dots & \xi_1^{(N-1)M+1} \cdot \xi_1^{NS} & \dots \cdot \xi_1^{N(N-1)} \end{bmatrix}$$

The diversity gain achievable by V-BLAST is potentially  $M$ , since  $M$  independently faded copies of each transmitted symbol are seen by the receiver. However, the zero-forcing nulling approach yields diversity gains on the order of 1 & only the ML sphere decoder comes close to achieving the maximum achievable gain of  $M$ .

2) H-BLAST Scheme

To improve upon the performance of V-BLAST, one approach is to add more antennas at the receiver, thus making more diversity gain available through observation of an increased number of redundant signal copies.



Another approach is to introduce traditional error control coding in the time dimension, thus improving the overall performance by some amount of coding gain. This strategy is applied in H-BLAST. The information-bearing bits carried in each space-time matrix are first partitioned into  $N$  words of length  $B$  & these words are then encoded by rate  $R$  outer encoders. The resulting codewords are modulated to produce  $N$  codewords each consisting of  $L$  symbols which are transmitted as shown.

$$\bar{\mathbf{s}} = \begin{bmatrix} \mathbf{c}_1 & \dots & \mathbf{c}_N \\ \vdots & \ddots & \vdots \\ \mathbf{c}_N & \dots & \mathbf{c}_N \end{bmatrix}$$

The H-BLAST receiver tasks are nearly the same as those for V-BLAST, with a few differences. In H-BLAST the ordering step considers the post-detection SNRs of each complete codeword in making its selection. The subsequent nulling & cancellation operations are based on codeword rather than symbol decisions. Also there is a small wrinkle in nulling step, which may be implemented using a symbol-by-symbol detector (as before in V-BLAST).

Alternatively, improved performance may be attained by using a sequence estimator or a soft-decision symbol-based approach. Overall the receiver complexity is higher than that of V-BLAST, because of the additional complexity imposed by the outer code & secondly because of the increased dimensionality incurred by working with codewords rather than symbols.

### 3) D-BLAST Scheme

Finally, we consider the structure & properties of the best & most sophisticated of the BLAST techniques. D-BLAST extends the outer coding introduced in H-BLAST to span both the space & time dimensions. Here information-bearing bits are transmitted per space-time matrix. They are first partitioned & then encoded by outer encoders. The resulting codewords are arranged for transmission in an  $N \times L$  symbol matrix as follows:

In terms of decoding, the D-BLAST detector performs essentially the same operations as those of the other BLAST variants. However, it is termed balanced since the symbols constituting each codeword are spread in both space & time.

### E. Perfect space-time codes

Perfect ( $n \times n$ ) space-time codes have been introduced recently as the class of linear dispersion space-time (ST) codes having full rate, non-vanishing determinant, a signal constellation isomorphic to either the rectangular or hexagonal lattices in  $2n^2$  dimensions, & uniform average transmitted energy per antenna. These codes are used for the coherent multiple-input multiple-output (MIMO) channel & are called so since they satisfy a large number of design criteria that makes their performances outmatch many other codes [12]. A perfect space time codes for any number of transmit antennas, any number of receive antennas, & any delay that is a multiple of  $n$  has been constructed in [13]. A perfect space-time code can provide the optimal performance in many theoretical & practical aspects. For example, a perfect space-time code can utilize the full coding rate to achieve the maximum throughput

of a MIMO channel. The property of non-vanishing determinant provides the optimal trade-off between spatial diversity & multiplexing. On the practical side, each information symbol can be encoded without the necessity of extra energy. The RF power amplifier can also be simplified based on the uniform average power of transmission over all transmit antennas & time slots [14]. The performance of the perfect space time codes in terms of an upper-bound on the pairwise error probability has been studied in [15], & compared with spatial division multiplexing (SDM) scheme. In the context of IEEE 802.11n it has been shown that the  $2 \times 2$  MIMO perfect code, i.e. the golden code performs relatively similarly as the SDM scheme in the presence of a good outer code.

### V. CONCLUSION

The goal in this paper is to present an overview of some fundamental approaches to space-time coding & present new areas of research in terms of design of perfect space time codes. This field is attracting considerable research attention in all of these areas. There are still open problems that deserve further investigation, especially in the area of design of STBC for frequency selective channels so as to achieve a higher spectral efficiency, while still maintaining a relatively low decoding complexity. In all of the techniques the Alamouti schemes shows scopes with its performance in terms of improving its BER.

### REFERENCES

- [1] Yusuf Acar et-al, "Generalized Prefix Approach for Alamouti Coded OFDM System over Gaussian Channels Correlated in Space", IEEE World Congress on Computer Applications and Information Systems (WCCAIS), 2014.
- [2] Feng He et-al, "A Novel Space-Time Coding Alamouti Waveform Scheme for MIMO-SAR Implementation", IEEE Geoscience and Remote Sensing Letters, Volume 12, No. 2, February-2015.
- [3] Benjamin K. Ng et-al, "Single-carrier time-interleaved space-time code for frequency-selective fading channels", IEEE 8th Sensor Array and Multichannel Signal Processing Workshop (SAM), 2014.
- [4] K. Jyostna et-al, "Performance Analysis of SC MIMO-CDMA System using STBC codes", 11th IEEE International Conference on Wireless and Optical Communications Networks (WOCN), 2014.
- [5] A. Paulraj, R. Nabar and D. Gore, "Introduction to Space-time Wireless Communications", Cambridge university Press. 2003.
- [6] Gregory D. Durgin, "Space-time Wireless Channels", Prentice Hall PTR. Pearson Education, Inc. 2003.
- [7] B. Vucetic, J. Yuan, "Space-time Coding", John Wiley & Sons Ltd, England. 2003.
- [8] Erik G. Larsson and P. Stoica, "Space-time Block Coding for Wireless Communications", Cambridge University Press. 2003.
- [9] J.C. Guey, M.R. Fitz, M.R. Bell, and W.Y. Kuo, "Signal Design for Transmitter Diversity Wireless Communication Systems Over Rayleigh Fading Channels," IEEE Transactions on Communications, Vol. 47, No. 4, pp. 527-537, April 1999.
- [10] J. H. Winters, "Diversity Gain of Transmit Diversity in Wireless System with Rayleigh

- Fading.” IEEE Transactions, Vol. 47, pp. 119-123, 1998
- [11] G. W. Wornell and M. D. Trott, “Efficient Signal Processing Techniques for Exploiting Transmit Antenna Diversity on Fading Channels”, IEEE Transactions on Signal Processing, Vol. 45, pp. 191-205, 1997.
- [12] W. Y. Kuo and M. P. Fitz, “Design and Analysis of Transmitter Diversity Using Intentional Frequency Offset for Wireless Communications,”. IEEE Transactions, Vol. 46, pp. 871-881, 1997.
- [13] V. Tarokh, H. Jafarkhani, and A.R. Calderbank, “Space-time Block Codes from Orthogonal Designs,” IEEE Transactions on Information Theory, Vol. 45, No. 5, pp. 1456-1467, July 1999.
- [14] S.M Alamouti, “A simple Transmitter Diversity Scheme for Wireless Communications”, IEEE Journal on Selected Areas in Communications, Vol. SAC-16, pp. 1451-1458, October 1998.
- [15] S. H. Nam, J. Chung, C. Hwang, and Y. Jung, “Differential Space-time Block Codes using Non-constant Modulus Constellations for Four Transmit Antennas”, IEICE Transactions on Communications, Vol. E88-B, No. 4, April 2005.
- [16] B. M. Popovic, “New Complex Space-time Block Codes for Efficient Transmit Diversity”, IEEE 6th International Symposium On Spread-Spectrum Tech & Applications, Sept. 6-8, 2000.
- [17] H. Jafarkhani, “A quasi-orthogonal Space-time Block Code,” IEEE Transactions on Communications, Vol. 49, No. 1, pp. 1-4, January 2001.
- [18] H. Jafarkhani, “Space-Time Coding: Theory and Practice”, Cambridge University Press, 2005.
- [19] V. Tarokh, N. Seshadri and A. R. Calderbank, “Space-time Codes for High Data Rate Wireless Communication: Performance Criterion and Code Construction”, IEEE Transactions on Information Theory, Vol. 44, No. 2, pp. 744-765, March. 1998.
- [20] V. Tarokh, S. M. Alamouti, and P. Poon, “New Detection Schemes for Transmit Diversity with no Channel Estimation,” IEEE International Conference, Universal Personal Communications, pp. 917-920, 1998.
- [21] J. Yang, E. Masood and Y. Sun, “Performance of Space-time Block Coding Using Estimated Channel Parameters”, London Communications Symposium Conference UCL, 2004.