

An Investigation on STATCOM based Reactive Power Compensation for Optimal Voltage Profile in Distributed Power Application

¹Mohammad Isharat Khan,²Dheeraj Kumar Palwalia

¹Research Scholar, EED, CP University, Kota, Rajasthan, ²Assistant Professor, RT University, Kota, Rajasthan

Abstract— The research article investigates on the importance of reactive power and reactive power compensation technologies implements in smart grid which are based on STATCOM. Reactive power injection in the smart grid is extremely important for system stability, voltage regulation, power factor enhancement, system reliability, system performance and overall efficiency of system. The quality of the transmitted power over long distance is subjected to the optimal insertion of reactive power. Reactive power management in smart grid is area of interest of research scholar since the transmission system comes in to existence. In this article we have carried out an analytical investigate on different technologies used for the objective task and also conduct the literature survey on the respective topic.

Indexed Terms — STATCOM, Reactive power, Static Var Compensators, Smart Grid

I. INTRODUCTION

The production, transmission and distribution of energy involve important costs such as fixed costs and operating costs. Based on the two types of costs, utility companies have established rate structures that attempt to be as equitable as possible for their customer. The rates are based upon the amount of energy consumed (kWh) and the power factor of the load. In electrical power consuming, the utility will record energy consumed for billing purpose. If the consumer uses electrical power inefficiently for example used load such as motor, air conditioner and others load which is drawn more current, the power utilities have to supply extra current to make up for the loss caused by poor power factor. Power factor would be unity, but we have seen in real world, power factor is reducing by highly inductive load to 0.7 or less. This induction is caused by equipment such as lightly loaded electric motors, fluorescent lighting ballasts and welding sets Voltage and Reactive power compensation is an important issue in electric power systems involving operational, economical and quality of service aspects consumer loads (residential, industrial, service sector. impose active and reactive power demand, depending on their characteristics. Active power is converted into “useful” energy, such as light or heat. Reactive power must be compensated to guarantee an efficient delivery of active power to loads, thus releasing system capacity, reducing system losses, and improving system power factor and bus voltage profile.

Reactive power compensation and voltage regulation are two effective measures to improve the voltage quality. Many works has been done aiming at the optimal compensation on distribution and transmission network. Optimal reactive power compensation (ORPC) models and algorithm research in distribution networks have made numerous progress based on mathematical programming or physical characteristic analysis. Power quality is an issue that is becoming increasingly important to electricity consumers at all levels of usage. There are many major cause effected on this quality of power. Generally, the problem of optimal reactive power planning (ORPP) can be defined as to determine the amount and location of shunt reactive power compensation while keeping an adequate voltage profile.

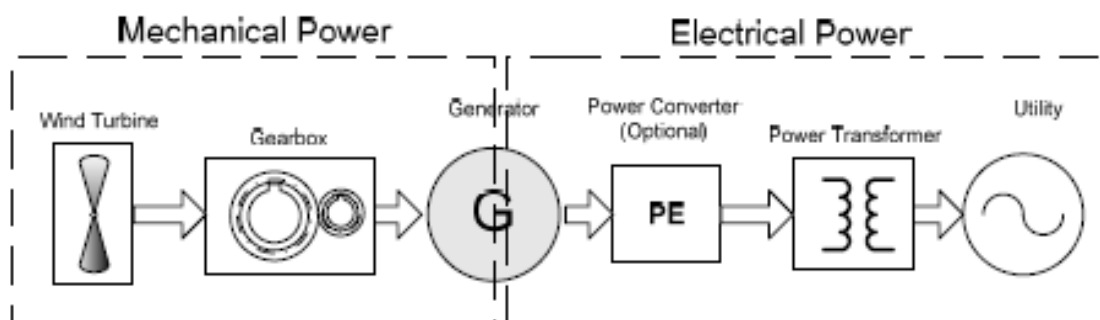

Figure-1. STATCOM based Reactive VAR Sample Injector

The voltage control can be achieved by providing sufficient reactive power resources to keep the voltage level at a desired nominal value regardless how much reactive power it takes. On the other hand, controlling the amount of reactive power injection at each node can be accomplished through the regulation of the voltage at the node

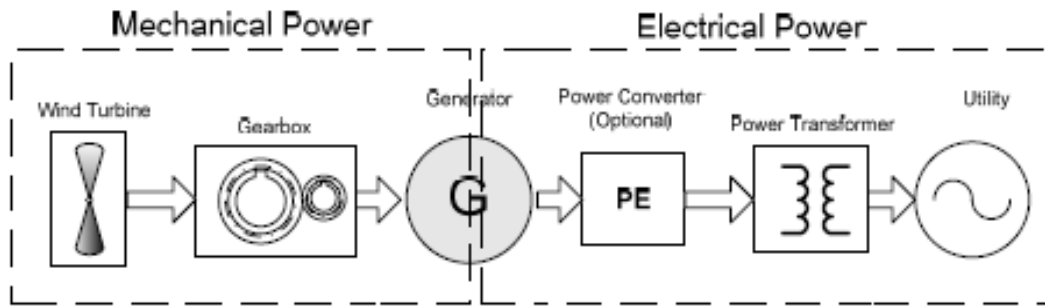

Figure-2. Generalized diagram of a wind energy system

This brings up the issue of difference between the voltage control and the reactive power control. Each one of the aforementioned control methods contains limitation. The control of the voltage by the reactive power is restricted to the limitations of reactive power resources and the control of the reactive power through the voltage is restricted to the feasible limits of voltage at each node.

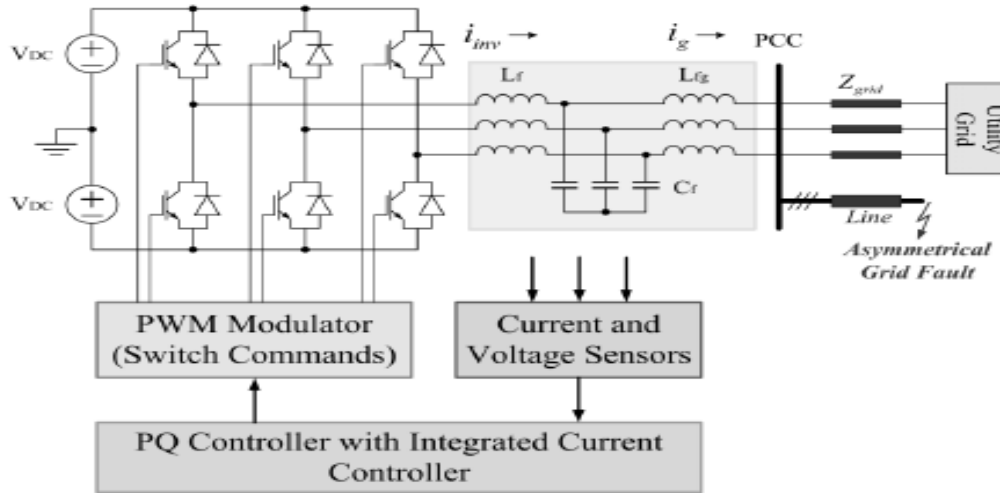

Figure-3. Voltage source inverter connected to the grid.

This will pick out the constrains of difference between the voltage control and the reactive power control. Each one of the aforementioned control methods contains limitation. The control of the voltage by the reactive power is restricted to the limitations of reactive power resources and the control of the reactive power through the voltage is restricted to the feasible limits of voltage at each node. Whenever the concern of the control is the reactive power resources, the aim could be either voltage or reactive power control, but not both of them at the same time. In the case of the transmission system, the control would be implemented on the system voltage.

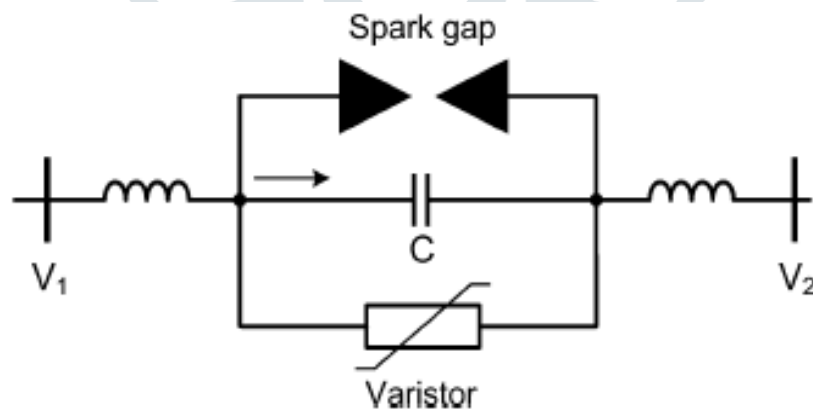

Figure-4. Series capacitor compensator and associated protection system

In normal operation state, the reactive power balance must be kept in such a way that the voltages are within acceptable limits. In fact inequality between reactive power generation and consumption does not exist and the reactive power generated and consumed is always equal. Therefore, an improper reactive power generation and consumption level in the system will result in inappropriate voltage profile.

Unlike the active power ancillary services that are frequency control reserves, the reactive power cannot be transmitted efficiently through long distances because it leads to additional active and reactive power losses. Reactive power losses are due to the large reactive impedance of the high voltage transmission system.

The operator of the power system is responsible to control the transmission system voltage which means enough reactive power available to prevent or mitigate voltage violation conditions. The system operator could respond to the voltage problem conditions asking for all available reactive support from its area and also from the neighboring systems.

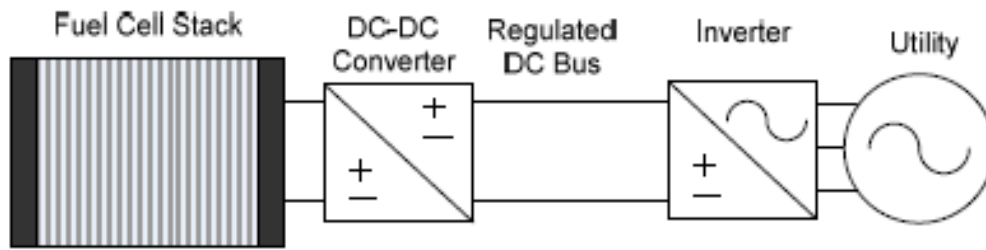

Figure-5. Power electronics coupling for a Fuel cell system

The system operators usually provide the voltage control services from generators and consumers within their own controlled area. It is due to the fact that reactive power transmission is a highly localized service. Principally this ancillary service is provided by the generators.

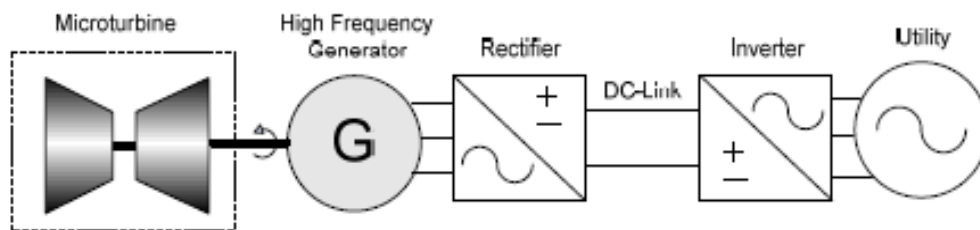

Figure-6. Typical power electronic coupling for a micro-turbine system

As a result, the voltage has to be controlled by using special devices dispersed throughout the system. In other words, reactive power generation and consumption have to be as close as possible to each other to avoid excessive reactive power transmission. Moreover, the regulation establishes some services to be supplied also by transmission and distribution systems.

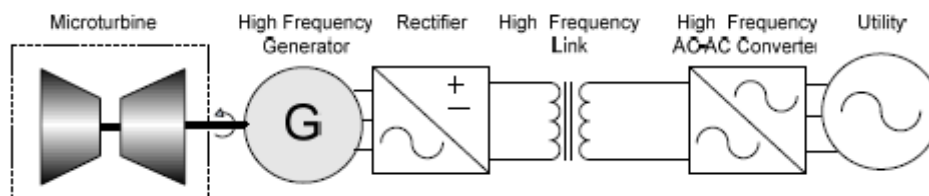

Figure-7. High frequency AC link coupling

Power system equipments provide a variety of actions for the system operator which could be undertaken to control the voltage and to schedule the production of reactive power. Synchronous generators are the backbone of the voltage control in the network. They are already available over entire the system and their voltage support are low-cost and simple to control. However, they are not the only ones and other reactive power resources in the power system are automatic transformer tap changer, synchronous condenser, capacitor banks, capacitance of overhead lines and cables, static VAR compensators and FACTS devices.

II. BACKGROUND

The voltage control from generation resources is a necessary supplement to static reactive devices to prevent voltage problem because:

1. Generation supplied reactive resources do not lose effectiveness at low voltage as do static reactive devices.
2. The response of a generator to an emergency reactive requirement is much faster and more accurate than the static reactive sources (except power electronic based devices).

The voltage control capability of synchronous generators is limited by saturation of both: field current and armature current. The generators under heavy real power loading require high amount of field current to maintain the desired terminal voltage which pushes the generator and exciter to the saturation region. When armature current limitation is in effect, a large reduction in the reactive power output is needed if the active power output is to remain constant.

The transmission customers can also supply reactive power to the system or can reduce the use of reactive resources by power factor correction. Note that even with a unity power factor, reactive supply and voltage control from generation sources is still required for dynamic voltage control, supplying reactive losses of the transmission system, and maintaining reactive reserves for security. Recently, provision of ancillary services by dispersed generation and demand side response became important. However, TSOs cannot effectively manage and operate the provided ancillary service by thousands of DG units. Therefore, their participation in the ancillary services is confronted with barriers at this time.

These voltage regulators can be operated in automatic or manual mode. From the system operation perspective, all voltage regulators should remain in automatic mode. Power plant operators for a short period of time may need to place voltage regulators in the manual mode because of maintenance, testing, or any problem in the generating units' voltage regulator. These automatic controllers are set by the control area operators in order to maintain a scheduled voltage in response to system changes due to a disturbance or an unusual increase of power demand.

The control of voltage could be accomplished with passive (shunt and series capacitors and reactors) and/or active (synchronous generators, synchronous condenser, and FACTS) devices. The former devices contribute to the voltage control by modifying the network characteristics, while the latter's automatically adjust the absorbed or supplied reactive power to maintain the voltages of buses at specific points in the system [6].

Another classification divides the voltage control devices into static and dynamic types [7]. Dynamic reactive power resources refer to equipment that can respond within cycle of a disturbance where static devices are not capable of reacting fast enough. Appropriate balance between static and dynamic reactive power resources in an area should be provided to obtain a feasible operating point after a reactive power deficit in the area [8].

A well-planned and coordinated application of these devices is essential for the economical design and operation of a reliable system [9]. The proper selection and coordination of equipment for controlling reactive power and voltage are among the major challenges of the power system engineering [9].

For efficient and reliable operation of the power system, the control of voltage should a) maintain the voltages of all terminals in the system within acceptable limits, b) enhance the system stability to maximize utilization of the transmission system, and c) minimize the reactive power flow so as to reduce active (RI₂) and reactive (XI₂) losses [9].

A power system at a given operating state and subjected to a given disturbance is voltage instable if the voltages could not approach post-disturbance equilibrium values. Basically, voltage instability has two origins: first, gradual increases of power demand without sufficient reactive power support, and second, a sudden change in the network topology which redirect the power flow in such a way that the required reactive power cannot be delivered to some buses.

III. LITERATURE SURREY

The Hellenic system was prone to voltage instability on July 12th 2004. This phenomenon is related to the maximum power transfer from the generating areas in the North and West of Greece to the main load center in the Athens metropolitan area. The Hellenic interconnected system (Greece network) blackout was a severe voltage collapse. At that time two generating units in Peloponnese and Northern Greece were out of service which was further stressing the Athens grid. The sequence of events leading to the blackout was started with the failure of 300 MW generating unit in Athens area. This unit was reconnected to the network but it was lost again due to high drum level.

During the incident, the power stations in the affected area lost their voltage control due to the over-excitation. Therefore, they lowered their pre-disturbance active generation in an attempt to increase their reactive capability and controlling their terminal voltage. This, however, had an adverse effect, as it increased the import of power into the affected area, thus creating further voltage drop despite the increased reactive generation.

The system of southern Sweden and eastern Denmark were experienced blackout on 23th September 2003. The operating conditions were stable within the Nordic security requirements. Initial disturbance was outage of nuclear power plant due to mechanical problem and loss of 1175 MW generation. This contingency managed through operational reserves and the supply-demand balance was restored. Within 15 minutes time to restore the system into N-1 secure state, a double bus bar failure is occurred which disconnected four 400kV transmission lines.

In 14 August 2003, several hours before the start of events, there was large volume of power transmissions through Ohio to the other areas. It led to high reactive power demand and consequently a severe shortage of reactive power in northern Ohio. But the supply of reactive power was low because some power plants were out of service and others were not producing enough reactive power. The sign of insufficient reactive power increased VAR production at nine of power plants in this area. It caused the generators to operate near limits with reduced reactive power reserves for contingencies.

In the North America power system, the enhanced voltage control is not utilized. Power plants are the primary resources used to control the transmission system voltage. The effectiveness of the existing reactive power and voltage control standards and how they are being implemented in practice has been reevaluated in the ten NERC regions [46]. New generators should have an over and under-excited power factor capability of 0.95 or less. If a generator could not meet this requirement, it should make alternate arrangements for supplying an equivalent dynamic reactive power capability. The provision of the basic voltage controls is compulsory in NERC. The generators are remunerated based on a regulated price. This price incurs the fixed and opportunity cost of the generators.

The short-term voltage stability is characterized by fast acting dynamics of the power system and its components following a disturbance. The time frame is from less than one second to several seconds. The response of the PVR is in this time scale. Time-domain or dynamic simulation considering different control actions are commonly used for the short-term studies.

In 2009, N.Karpagam et al. [4] discusses about Static VAR Compensator (SVC) which is a shunt type FACTS device which is used in power system primarily for the purpose of voltage and reactive power control. Authors developed a fuzzy logic based supplementary controller for Static VAR Compensator (SVC) which is used for damping the rotor angle oscillations and to improve the transient stability of the power system. Generator speed and the electrical power are chosen as input signals for the Fuzzy Logic Controller (FLC). The effectiveness and feasibility of the proposed control is demonstrated with Single Machine Infinite Bus (SMIB) system and multi machine system (WSCC System) which shows improvement over the use of a fixed parameter controller.

In 2010, Karuppanan P et al. [8] describes the proportional integral (PI), proportional integral derivative (PID) and fuzzy logic controller (FLC) based three phase shunt active power line conditioners (APLC) for the power-quality improvement such as reactive power and harmonic current compensation generated due to nonlinear loads. PI, PID controller requires precise linear mathematical model and FLC needs linguistic description of the system. According to the authors the controller is capable of controlling dc capacitor voltage and generating reference source currents. Hysteresis current controller is used for current control in PWM voltage source inverter. Extensive simulation studies under transient and steady states are conducted, the simulation result analysis reveal that the APLC performs perfectly in conjunction with PI, PID and FLC.

In 2012, S.Kavitha et al. [9] aims at designing and implementing a fuzzy controller for Multiple Input Single Output temperature process. Temperature control of water in the tank is achieved by varying current to the heating rod and inlet flow rate by a fuzzy controller. According to the author the system consists of a tank, reservoir, variable speed pump, temperature sensor placed inside a heating tank containing the heating rod, voltage controlled current source and computer. Water is pumped into the tank from reservoir and RTD measures the current temperature. The signal from the temperature sensor is sent to the DAQ interfaced to the computer. LabVIEW software is used to acquire the input signal and send the output signal that is determined by the control algorithm. Fuzzy logic controller is designed in LabVIEW. Based on the set point temperature, the controller sets the appropriate current to the heating rod. If the required temperature is less than that sensed by the temperature sensor, the flow rate of water into the tank is controlled by a variable speed pump. While conventional controllers are analytically described by a set of equations, the FLC is described by a knowledge-based algorithm. Thus this system is highly efficient in both heating and reducing the temperature of the tank. A fuzzy logic controller gives faster response, is more reliable and recovers quickly from system upsets. It also works well to uncertainties in the process variables and it does not require mathematical modelling.

In 2012, Ashish Choubey et al. [10] discusses to enhance power supply reliability for the user terminals in the case of the distribution system to avoid interference by the fault again, rapidly complete the automatic identification, positioning, automatic fault isolation, network reconfiguration until the resumption of supply of non-fault section, a microprocessor-based relay protection device has developed. As the fault component theory is widely used in microcomputer protection, and fault component exists in the network of fault component, it is necessary to build up the fault component network when short circuit fault emerging and to draw the current and voltage component phasor diagram at fault point. In order to understand microcomputer protection based on the symmetrical component principle, they obtained the sequence current and sequence voltage according to the concept of symmetrical component.

In 2013, Bijay Baran Pal et al. [14] presents how fuzzy goal programming (FGP) method can be efficiently used modeling and solving power generation and dispatch (PGD) problems in power system operation and planning horizon. According to the authors objectives of a problem involved with optimal power flow computation are considered fuzzy in nature in an uncertain decision environment. In the solution process, min sum FGP methodology is addressed to minimize the deviations from the aspired goal levels and thereby to reach a satisfactory decision on the basis of needs and desires of the decision maker (DM) in the decision making context.

IV. REACTIVE POWER COMPENSATION PRINCIPLES

Reactive Power Injection sets the reactive power injection levels of the PV inverters according to a predefined relationship between the inverter power factor and the LV bus voltage. One variation is to specify the required power factor according to the feeder bus voltage, as shown in Figure 3.3, and then calculate the required reactive power injection as a function of the actual real power injection [15]. Another alternative is to calculate the “characteristic power factor” and hence the required reactive power injection, as a function of the inverter real power output, as shown in Figure 3.4. In either case, the inverter reactive power output is subject to the constraint that the inverter has the kVA capacity to provide the commanded reactive power. Otherwise the maximum possible injected reactive power is limited by the inverter kVA rating.

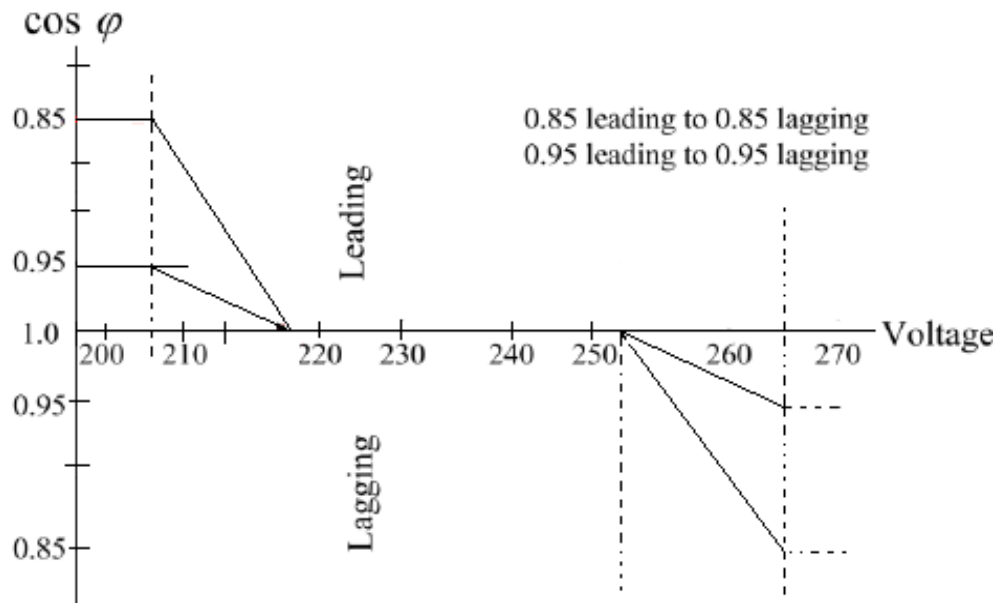

Figure-8.Volt-Var control mode

Note that lagging power factor is defined as when reactive power flows from the grid to the inverter; that is, when the inverter acts as an inductive load from the grid perspective. However, while RPM is designed to enable PV inverters to inject or absorb reactive power, its primary objective is not to control bus voltages but only to try and reduce voltage rises along the LV feeder caused by PV real power injection.

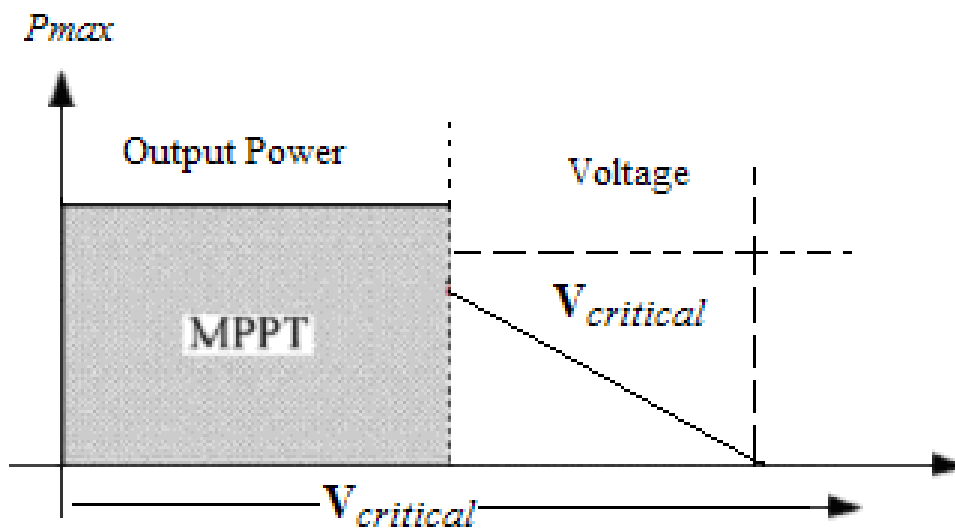

Figure-9.Power Curtailment Strategy

$$P_{inverter} = \begin{cases} P_{MPPT} & V_{inverter} < V_{crit} \\ P_{MPPT} - K_{drop}(V_{inverter} - V_{crit}) & V_{inverter} > V_{crit} \end{cases} \dots \dots \dots Eqs-1$$

where :

$P_{inverter}$ is the output power of the inverter, based on the inverter voltage V_{crit} .

If this is less than a critical voltage V_{crit} the inverter will operate with maximum PV power input.

Otherwise, the inverter output power is defined based on the droop coefficient.

The performances of these four exemplar state-of-the-art reactive power injection strategies are now compared, looking at voltage rise across the feeder and feeder losses over a daily load and PV energy injection profile.

Increasing levels of distributed generation penetration in the utility grid are changing conventional electrical network characteristics. Such distributed sources can be placed anywhere in the system including near or at the end user, with multiple small-scale technologies being used to produce electricity. In addition, these technologies can take advantage of renewable energy sources such as wind and solar. Consequently, this can cause bidirectional flow of power in the utility network, which complicates the control of real and reactive power flows. Therefore, control of a DG unit becomes very important as its contribution to the overall system performance can be positive, or it can worsen the situation. The control of such DG units has

been the focus of significant research effort for more than a decade, with the control under abnormal conditions (such as unbalanced voltages) being given more focus in more recent years.

V. CONCLUSION

In this research article we had presented the role and importance of active and reactive power in smart grid. More focus had been kept on the application of STATCOM based reactive power controller for its utility in smart grid.

The unique advantages of using power electronic couplings have been discussed throughout the paper and can be summarised in the following features:

1. Flexibility to integrate energy storage units in the converter DC link to provide power quality support and ancillary services such as reactive support by generating units and loads,
2. Maximum power point tracking for PV and wind energy systems,
3. Dispatching capabilities with energy storage units,
4. Improved efficiency
5. Variable speed operation ability allowing for fuel usage optimization.

VI. FUTURE SCOPE

In order to make possible all the potentialities mentioned in the paper, intensive research and development in the power electronics technology is strongly needed. The application of STATCOM based reactive power compensator is important in smart grid. Smart Grid is future technology. There is scope of lots of the research work is needed to be carried out in the respective field in order to make industrial and commercial application of the reactive power compensator to as to make smart grid more efficient and more reliable.

REFERENCES

- [1] Power Electronics for Distributed Energy Systems and Transmission and Distribution Applications, Technical Report Oak Ridge National Laboratory ORNL/TM-2005/230 Dec. 2005.
- [2] W. Kramer, S. Chakraborty, B. Kroposki, H.Thomas, "Advanced Power Electronics Interfaces for Distributed Energy Systems," Technical Report National Renewable Energy Laboratory NREL/TP-581-42672 March 2008.
- [3] R. H. Staunton, B. Ozpineci, "Micro turbine power conversion technology review," Report Oak Ridge National Laboratory ORNL/TM-2003/74, April 2003
- [4] Frede Blaabjerg, Zhe Chen, and Soren Baekhoej Kjaer, "Power Electronics as Efficient Interface in Dispersed Power Generation Systems," IEEE Trans. Power Electron., vol. 19, no. 5, pp. 1184-1194, Sep. 2004.
- [5] F. Delfino, R. Procoppio, "Photovoltaic generating units as reactive supply ancillary service providers," in International Journal of Emerging Electric Power Systems, vol. 9, no. 4, Oct. 2008.
- [6] A.K. At Jabri and A.I. Alodah, "Capacitance requirements for isolated self-excited induction generator," Proc. IEE, Vol. 137, Part B, No. 3, pp.154-159, May 1990.
- [7] Al-Bahrani, A.H., and Malik, N.H, "Selection of the Excitation Capacitor for Dynamic Braking of Induction Machines", Proc. IEE, Vol. 140, Part. B, No. 1, pp. 1-6, 1993
- [8] Al-Bahrani, A.H., and Malik, N.H, "Steady state analysis and Performance Characteristics of a three phase Induction Generator Self-Excited with a single capacitor", IEEE Trans. on Energy Conversion, Vol4, No. 4, pp. 725-732, 1990
- [9] T.F. Chan, "Capacitance requirements of Self-Excited Induction Generators", IEEE Trans. on Energy Conversion, Vol. 8, No. 2, pp. 304-310, June 1992.
- [10] N. Ammasagounden, and M. Subbiah, Microprocessor based voltage controller for wind-driven self-excited induction generators, IEEE Transaction Industrial Electronics, Vol. 37, No. 6, December 1990, pp. 531-537.
- [11] G. Boyle, Renewable Energy: Power for Sustainable Future, (Oxford University Press, 2000).
- [12] N. Jenkins, R. Allan, P. Crossley, D. Kirschen, and G. Strbac, Embedded generation (The Institute of Electrical Engineers, 2000).
- [13] G. Raina, and O.P. Malik, Wind energy conversion using a self-excited induction generator, IEEE Transaction on Power Apparatus and Systems, Vol. 102, No. 12, 1983, pp. 3933-3936.
- [14] Elder J.M., Boys J.T., and Woodward J.L., Self-excited induction machines as a small low cost generator, Proceeding IEE, Vol. 131, Part C, No. 2, pp. 33-41, 1984.
- [15] S.M. Alghuwainmen, Steady-state analysis of self-excited induction generator including transformer saturation, IEEE Transactions on Energy Conversion, Vol. 14, No. 3, September 1999. McPherson G., and Laramore R.D., An Introduction to Electrical Machines and Transformers. (New York, Wiley, 1981).
- [16] L. Quazene and G. G. McPherson Jr., Analysis of an isolated induction generator, IEEE Transactions on Power Application System, Vol. 102, No. PAS-8, August 1983, pp. 2793-2798.
- [17] T.S. Jayadev, Windmills stage a comeback, IEEE Spectrum, Vol. 13, No. 11, November 1976, pp. 45-49.
- [18] R.C. Bansal, Three-phase self-excited induction generators: an overview, IEEE Transactions on Energy Conversion, Vol. 20, No. 2, June 2005, pp. 292-299.
- [19] F.C. Dezza, A.D. Geriando, and R. Perini, Performance comparison among different converters fed by self-excited wind driven induction generators, Proceeding 7th International Conference on Electric Machine Drives, pp. 438-443, 1995.

- [20] M.S. Vicatos, and J.A. Teqopoulos, Steady state analysis of a doubly-fed induction generator under synchronous operation, IEEE Transaction Energy Conversions, Vol. 4, No. 3, September 1989, pp. 495-501.
- [21] M.G. Loannides, Determination of frequencies in autonomous double output asynchronous generator, IEEE Transactions Energy Conversions, Vol. 7, No. 4, December 1992, pp. 287-297.
- [22] Z. Slameh, and S.Wang, Microprocessor control of double output induction generator, Part-I: inverter firing circuit, IEEE Transaction Energy Conversions, Vol. 4, No. 2, June 1989, pp. 172-176.
- [23] R.C. bansal, T.S. Bhatti, and D.P. Kothari, A bibliographical survey on induction generator for application of non conventional energy systems, IEEE Transactions on Energy Conversions, Vol. 18, No. 3, September 2003, pp. 433-439.
- [24] R.C. bansal, T.S. Bhatti, and D.P. Kothari, Induction generator for isolated hybrid power system applications: A review, Proceeding 24th National Conference on Renewable Energy Conversion, Bombay, pp. 462-467, 2000.
- [25] A.K. Tandon, S.S. Murthy, and G.J. Berg, "Steady State Analysis of Capacitor Self Excited InductionGenerators," IEEE Trans. on Power App. and Sys.Vol. PAS-103, No. 3, pp. 612- 618, 1984.
- [26] Rahim, Y.H.A., "Excitation of Isolated Three-phase Induction Generator by a single capacitor", IEE Proc.,Pt. B., Vol.140, No. 1, pp. 44-50, 1993.
- [27] Malik, N.H; and Mazi, A.A. "Capacitance requirements for isolated Self excited Induction Generators", IEEE Trans. on Energy Conversion,Vol. EC-2, No. 1, pp. 62-69, 1987.
- [28] B. Mogstad, M. Molinas, P. K. Olsen, R. Nilssen, "A power conversion system for offshore wind parks," in Proc. of the 34th Annual Conference of the IEEE Industrial Electronics Society IECON 2008, Florida, USA Nov. 2008.
- [29] M. Molinas, O. Skjervheim, P. Andreasen, T. Undeland, J. Hals, T. Moan, B. Sorby,"Power Electronics as grid interface for actively controlled wave energy converters," in Proc. of International Conference of Clean Electrical Power, Capri Italy, May 2007.
- [30] F. Schimpf, L. Norum,"Grid connected converters for photovoltaic, state of the art, ideas for improvement of transformer less inverters," in Proc of NORPIE 2008, Finland, June 2008.
- [31] W. Short, P. Denholm, A preliminary assessment of plug in hybrid electric vehicle in wind energy markets, National Renewable Energy Laboratory NREL/TP-620-39729.
- [32] S. Lentendre, P. Denholm, Power Utilities Fortnightly, pp. 28-37, Dec. 2006. Brooks, Vehicle to grid demonstration project: grid regulation ancillary service with a battery electric vehicle, AC propulsion , Dec. 2002.
- [33] M. Molinas, D. Moltoni. G. Fascendini, J.A. Suul, R. Faranda, T. Undeland, "Investigation on the role of power electronics controlled constant power loads for voltage support in distributed AC systems," in Proc. of IEEE Power Electronics Specialists Conference, Rhodes, Greece, June 2008.
- [35] IEEE 1547 Standard for Interconnecting Distributed Resources with Electric Power Systems
- [36] E. Santi, D. Franzoni, A. Monti, D. Patterson, F. Ponci, N. Barry, "A fuel Cell Based Domestic Uninterruptible power Supply," in proc, APEC 2002 Conf, 2002, vol. 1, pp. 605-613.