

Patient Monitoring In Hospital Using Li-Fi

Vaishnavi Bhope¹, Aishwarya Naikwadi², Snehal Gilbale³, Supriya S. Shinde⁴

^{1,2,3}Student's, Department of Computer Engineering, JSPM's, BSIOTR, Pune University, India.

⁴Assistant Professor, Department of Computer Engineering, JSPM's, BSIOTR, Pune University, India.

Abstract— Li-Fi represents Light Fidelity. Li-Fi is a bidirectional, fast and completely organized remote optical communication and is a type of VLC. The proposed model aides in the Patient observing in the clinics/ hospitals and should be possible by utilizing the idea of Li-Fi rather than the Wi-Fi innovation to keep away from the frequency interference with the human body. Sensors, for example, temperature, blood pressure and heartbeat utilized in this model play out its particular functions. These sensors gather the information from the human body and are changed over in to the computerized frame utilizing the simple to advanced converter and the values of these sensors is fed to the microcontroller. The values from the microcontroller is bolstered to the Li-Fi module which transmits the information as light and the receivers end gather this information and after that shows the parameters on LCD in specialist's/ doctor's cabin.

Keywords— IOT, Embedded System, Li-Fi, Sensors, Micro-controller.

I. INTRODUCTION

In the era of emerging technology, it is necessary to find better solutions for every activity. Patient monitoring can be done in a very efficient manner using the Li-Fi technology. Monitoring of patient is done by the Li-Fi is faster when compared to the Wi-Fi and it also has more bandwidth. Reliability is less in Wi-Fi than Li-Fi. Since transmission of data by Wi-Fi is through RF waves, there is a high possibility that these waves might affect the human body. The designation of these signals may be carcinogenic and this has been given by the World Health Organization. To solve this issue, Li-Fi (light fidelity) technique is used for healthy environment. Light fidelity is transmission of information through optical wireless medium. In this model, sensors such as temperature, blood pressure and heart beat are cast-off to transmit data through the Li-Fi module. Rapid signals are produced in the form of 1s and 0s. Photo diode/ Solar panel is used at the receiver end. Flickering of light takes place at the rate of hundreds of megabits per seconds. By using UART, the receiver is connected to computer. The information is displayed in computer can be sent as a mail to the person concerned. The range of the Li-Fi technology is 10m and secured communication is possible. The transmission of information by light through wireless is termed as Visible Light Communication (VLC).

II. LITERATURE REVIEW

The reason for depending on wireless network in hospital is the cables which are running over the patient's body interconnecting the devices may cause contamination. Dependency on the wireless internet increases the burden on wireless fidelity (Wi-Fi) technology which, in turn, creates a huge demand for bandwidth and radio spectrum [1]. To reduce the load on Wi-Fi, an alternate mean of wireless internet is Li-Fi finds which find its applications in almost every field, even in vehicle technology [2].

For a long time, medical technology has lagged behind the rest. The scope for wireless communication in the medical field is set on the rise; there are many devices which work on Wi-Fi such as infusion pumps, defibrillators, lung ventilators, and anesthesia machine. When a doctor is supposed to use magnetic resonance imaging scanners along with infusion pumps, which work on Wi-Fi there results a frequency-overlapping problem. With more and more number of wireless medical devices coming up, utilizing the radio frequency (RF) spectrum increases which lead an electromagnetic interference (EMI) that results in potentially hazardous events related to medical equipment operations [3]. Apart from the interference with medical equipment, an EMI affects human body also in the form of diseases, immune dysfunction, electromagnetic hypersensitivity, etc., and in worst case, it may lead to cancer. Another limitation of Wi-Fi in hospital system is its security issue. Patient information must be private and secure but remain accessible to authorized persons. Hospitals are places where both EMI sensitivity and security of medical details are issues with the uses of Wi-Fi. To combat the above limitations of Wi-Fi in health monitoring system, Li-Fi is used, which is a novel technology for high-density wireless data coverage relieving radio interferences in confined areas [4].

VLC has definite scope in many areas such as smart stores, consumer electronics, defense and security, vehicle and transportation, aviation, hospital, underwater communication, and hazardous environment and it has spread across the regions of America, Europe, and Asia-pacific. The VLC market is expected to grow from USD 327.8 million in 2015 to USD 8,502.1 million by 2020, at a Compound Annual Growth Rate of 91.8% between 2015 and 2020. The global Li-Fi market is expected to exhibit growth at a robust pace between 2016 and 2023. Massive bandwidth owing to the growing RF spectrum crunch, together with a high degree of security and energy efficiency are expected to bolster the global Li-Fi market. Since the technology involves visible light wavelength and not radio waves, it is less likely to have a negative effect on human health. Experts often compare Li-Fi to free space optics as it also utilizes light to transfer data [5] but it cannot be used in the places where it is difficult to lay the optical fiber like hospitals. Parallel working with various EMI devices is feasible with Li-Fi and is also beneficial for robotic surgeries and automated procedures. During surgery, Li-Fi system along with various sensors is needed to get immediate guidance from experts in the therapy by sharing data, videos/live details about the patient for the best results [6].

III. EXISTING SYSTEM

In general, the Temperature, Pressure and Heart Beat of the patients in ICU are sensed by sensors and monitored by computer or the readings are taken manually. As the technology grows, these are performed using Wi-Fi. But, Wi-Fi is not advisable to use in ICU. Hence, the eco-friendly technology called Li-Fi has bloomed into existence, where many devices in a room can exchange data using light. This is called as Visible Light Communication (VLC). In Bio-medical field, the usage of Li-Fi has extended in transmitting the Electroencephalography (EEG) signal via VLC link.

IV. PROPOSED SYSTEM

The patient in ICU needs ultimate care and continuous monitoring. The Temperature, Pressure and Heart beat of each patient are sensed by corresponding sensors. These analog signals are converted into Digital form and are stored in a Microcontroller. From the microcontroller the data is transmitted through the light and received by a Photo detector. The receiver which is placed in the room, containing Universal Asynchronous Receiver Transmitter (UART) can be connected receiver model and the values can be displayed continuously. Hence, the patient can be monitored 24*7 and their details are updated easily.

V. PROBLEM STATEMENT

The radio frequencies are harmful for human beings so our proposed technology uses LED's for data transmission which ultimately increases the speed of data transmission and reduces the power consumption and use the wide range of bandwidth.

VI. SYSTEM ARCHITECTURE

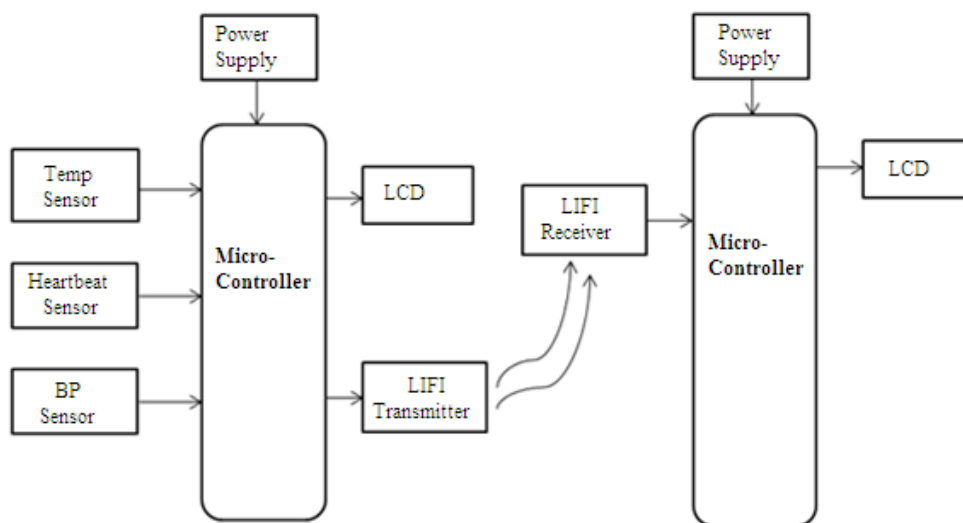

Fig1: System architecture

The working of the Li-Fi module is not difficult. It uses the concept of LEDs where logic 1 represents the data transmission and logic 0 represents that there is no transfer of data. The patient monitoring using the Li-Fi is done with the help of sensors. The sensors that are used in this model are heartbeat, temperature and blood pressure which will perform its necessary function. The sensed data are converted into the digital form using the ADC which is inbuilt in the microcontroller. The data is then transmitted with the help of Li-Fi module in the form of light. The off and on of the LEDs designates the absence and presence of the data. Fast signals are produced by the flickering of these LEDs which generates series of 1s and 0s. With the use of photo diode the light is then detected in the receiver's end. The received data can be characterized in the form of table/chart to analyse the patients' health.

VII. ADVANTAGES

- Since data is transmitted through LED, the availability of the source of transmission is easy and available cheaply.
- As light waves cannot penetrate through walls the information transmitted is much secured and cannot be misused.
- It has higher bandwidth .
- With the advent of Li-Fi one can surf the net by simply standing under the light.

VIII. CONCLUSIONS

This architecture is considered as a starting point into developing a scalable and generic Geo Li-Fi based system for indoor and outdoor environments. The system aims to develop a CMS for Li-Fi generated content and a mobile based application for regular users. The first three tiers of the system are currently under development. When the system is deployed and fully functional, data will be collected and analysed according to different scenarios. As the Li-Fi importance grows, the need for such systems will grow consequently.

REFERENCES

- [1] Shivaji K, Amogh D, Pavan J. A survey on Li-Fi technology. In: Proceeding of International Conference on Wireless Communication, Signal Processing and Networking (WiSPNET), March; 2016.
- [2] Pooja B, Ratul M, Balaji S. Smart vehicular communication system using Li Fi technology. In: Proceeding of International Conference on Computation of Power, Energy Information and Commuication (ICCPEIC), April; 2016.
- [3] van der Togt R, van Lieshout EJ, Hensbroek R, Beinat E, Binnekade JM, Bakker PJ. Electromagnetic interference from radio frequency identification inducing potentially hazardous incidents in critical care medical equipment. JAMA 2008;299(24):2884-90.
- [4] Chang HJ. Framework for data communication in the hospital using Li-Fi technology. Int J Sci Eng Res 2016;7(8):637-9.
- [5] Available from: <http://www.medgadget.com/2016/07/li-fi-market-increasing-demand-for-applications-in-medical-centers.html>.
- [6] Aminian M, Naji HR. A hospital healthcare monitoring system using wireless sensor networks. J Health Med Inform 2013;4(2):1-6.
- [7] Rahane SL, Pawase RS. A healthcare monitoring system using wireless sensor network with GSM. Int J Adv Res Electr Electron Instrum Eng 2015;4(4):6330-5.
- [8] Tan YY, Chung WY. Mobile health-monitoring system through visible light communication. Biomed Mater Eng 2014;24(6):3529-38.
- [9] "Li-Fi (Light Fidelity)-The future technology In Wireless communication", International Journal of Applied Engineering Research, ISSN 0973-4562 Vol.7 No.11 (2012)
- [10] Automated Billing System Using Li-Fi (Light Fidelity) Technology. Available from: <http://www.google.com>.