

Three port Bi-directional AC-DC Converter with Partial Power Processing Stages

*Nikhat Farheen, Gopinath Harsha .R.
M.Tech Student, Assistant Professor
PDA College of Engineering, Kalaburagi 585102*

Abstract—A new three port bi-directional AC-DC converter is proposed in this paper for battery energy storage applications. Here, the charging and discharging of the battery is done by both direct DC power port and through bi-directional DC-DC converter and thereby reducing the power processed by DC-DC converter and hence reducing the switching losses. The switching losses are further reduced by reducing the number of switches in direct DC power port. The three port bi-directional AC-DC converter is tested in both forward and reverse modes with supply and load connected on AC side terminals respectively. The model is simulated in MATLAB/Simulink software package.

I. INTRODUCTION

Battery energy storage systems is an essential part in various applications such as electric vehicles, microgrids, UPS, etc., The conventional method used for energy transfer between AC source and battery is by the two stage architectures consist of bi-directional DC-DC converter and bi-directional AC-DC converter as shown in the following figure:

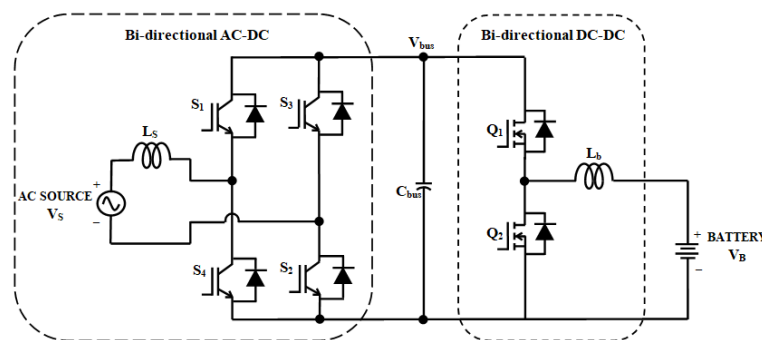

Fig.1. Conventional two stage bi-directional AC-DC converter

A bi-directional DC-DC converter is introduced for discharging and charging operations of the battery. The DC bus voltage is maintained as constant with the help of the bi-directional DC-DC converter. In this topology, the power is processed twice and hence the losses will be high. The multilevel converter topologies are introduced to raise the system performance. By increasing the number of levels on DC voltage, the switching losses on lower level switches will be reduced but the cost and size of the converter gets increased. Also soft switching is adapted to reduce the losses, but all these topologies concentrate on any one of the two stages and due to the other stage conversion process, the efficiency is still less. Single stage z-source converters are introduced in the place of two stage conventional converters. This also failed due to limited boost factor, higher voltage stresses on the switches, etc. Resonant converters are introduced with zero voltage switching (ZVS) to minimize the losses but with variations in input or output voltages, the efficiency is drastically reduced. High gain non isolated DC-DC converters are developed with shunt resonant circuit with voltage multiplier circuits. Zero voltage switching and zero current switching are achieved and the losses were reduced. But for low power applications and due to high frequency the efficiency gets reduced. Then non isolated current fed bi-directional DC-DC converter is designed and implemented with zero current switching (ZCS). Dual active half bridge converters are introduced to increase the boost factor and also to reduce the stress on the switches. The transformer is replaced by coupled inductor to reduce the circulating current and thereby reduce the losses. A single phase buck-boost power factor corrector (PFC) is introduced to reduce the power loss for high power applications. But the losses were increased in low power applications and also the harmonics gets increased in buck mode, and also the transition between buck and boost modes results in reduction of power factor and increase in harmonic distortion.

Three power interfacing ports, i.e., a DC bus port, a DC power port, and an AC port, are provided by the three port converter. The partial power processing concept is introduced in order to reduce the stages and thereby reducing the losses. In this paper, a new multi port multilevel converter is introduced in which if supply voltage is lesser than the battery voltage, battery can be charged or discharged with direct DC power port switches and when the battery voltage is less than supply voltage, it is processed by the bi-directional DC-DC converter buck-boost and then the battery gets charged or discharged.

II.THREE PORT BI-DIRECTIONAL AC-DC CONVERTER

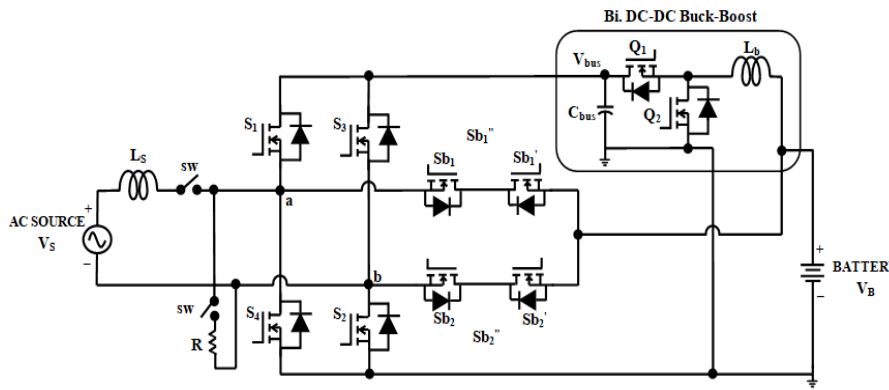

Fig.2. Three port bi-directional AC-DC converter

As shown in fig.2 the three port bi-directional AC-DC converter consist of an AC source with a single pole switch, H-bridge converter (S_1, S_2, S_3, S_4), two bi-directional switches ($S_{b1''}$ and $S_{b2''}$), where $S_{b1''}$ consists of S_{b1} and S_{b1}' and $S_{b2''}$ consists of S_{b2} and S_{b2}' , these switches are connected between the legs 'a' and 'b' of the conventional bridge converter, bi-directional DC-DC buck-boost converter (Q_1 and Q_2), capacitor, inductor, battery and an R load with a single pole switch. The source inductance L_s is used to modify the performance parameters of the converter..

As the battery voltage rating is less than the peak supply voltage, we can provide proper switching for the three port converter. The bi-directional switches of the three port bi-directional AC-DC converter is series connected MOSFET's with reverse blocked diodes/switches and also the converter's reliability will not be affected.

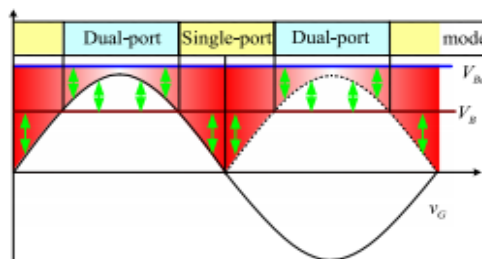

Fig.3. Operational modes for three port bi-directional AC-DC converter

The operational modes of the three port bi-directional AC-DC converter are provided as follows:

RECTIFYING MODE (FORWARD):

The operational modes of the three port bi-directional AC-DC converter shown in fig.3 is provided, for the rectifying mode of operation (forward mode) with the single pole switch (sw) across the AC source closed and with the single pole switch (sw) across the R load open. The AC source operates as the supply and the battery is taken as load in this mode of operation.

Single Port mode (Forward):

The converter will operate in this mode, when $V_s < V_B$. In this, $S_{b1''}$ and S_2 operate, the AC source is connected to the battery, and the energy is transferred from the AC source to the battery directly through the DC power port (i.e., the third port) of the three port bi-directional AC-DC converter and the battery gets charged as shown in fig.4.a. In positive cycle, $S_{b1''}$ and S_2 operate and in negative cycle $S_{b2''}$ and S_4 operate.

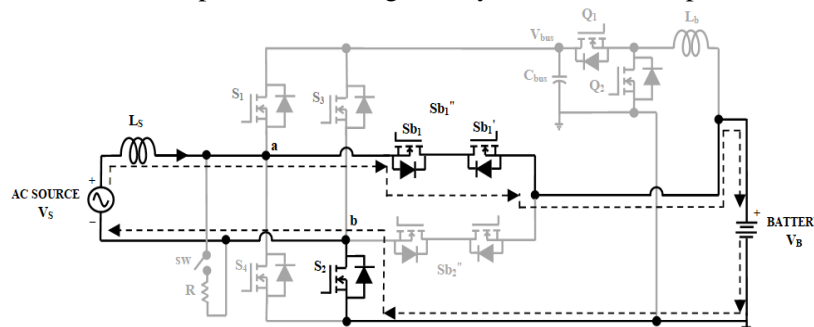

Fig.4.a. Single port mode (Forward)

Dual Port mode (Forward):

The converter operates in this mode, when $V_S > V_B$. In this, S_1, S_2 and Q_1 operate, the AC source is connected to the battery, and the energy is transferred from the AC source to the DC-DC buck-boost converter which bucks the voltage to the desired value sufficient for the battery V_B and then it is provided to the battery and the battery gets charged as shown in fig.4.b. In positive cycle, S_1, S_2 and Q_1 operate and in negative cycle S_3, S_4 and Q_1 operate.

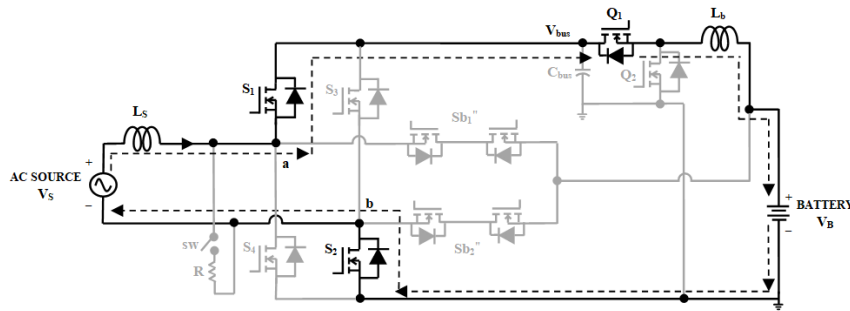

Fig.4.b. Dual port mode (Forward)

INVERTING MODE (REVERSE):

The operational modes of the three port bi-directional AC-DC converter shown in fig.3 is provided, for the inverting mode of operation (reverse mode) with the single pole switch (sw) across the AC source open and with the single pole switch (sw) across the R load closed. The battery operates as the source and the R is taken as load in this mode of operation. The power for the load will be supplied from the battery.

Single Port mode (Reverse):

The converter will operate in this mode, when $V_S < V_B$. In this mode, Sb_1'' and S_2 operate, the battery is connected to the R load, and the energy is transferred from the battery to the R load directly through the DC power port (i.e., the third port) of the three port bi-directional AC-DC converter and the battery gets discharged as shown in fig.4.c. In positive cycle, Sb_1'' and S_2 operate and in negative cycle Sb_2'' and S_4 operate.

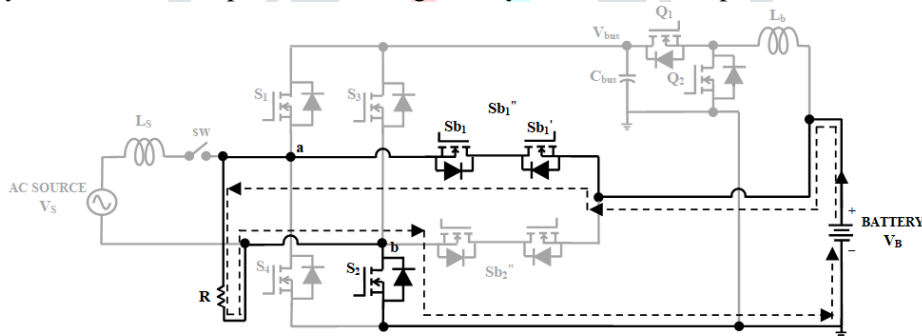

Fig.4.c. Single port mode (Reverse)

Dual Port mode (Reverse):

The converter will operate in this mode, when $V_S > V_B$. In this mode, S_1, S_2 and Q_2 operate, the battery is connected to the R load, and the energy is transferred from the battery to the DC-DC buck-boost converter which boosts the voltage to the desired value and then it is provided to the R load as shown in fig.4.d. The battery gets discharged during this mode of operation. In positive cycle S_1, S_2 and Q_2 operate and in negative cycle S_3, S_4 and Q_2 operate.

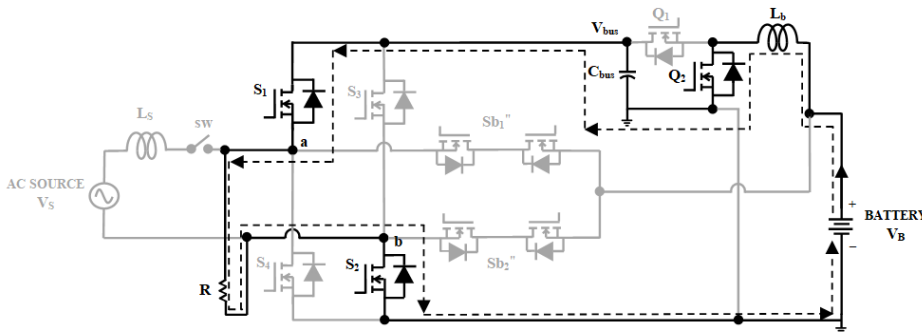

Fig.4.d. Dual port mode (Reverse)

In rectifying mode, the voltage and current is of opposite polarity and in the inverting mode, the voltage and current is of the same polarity.

From the three port bi-directional converter topology, the direct DC power port switch setup is modified as shown in fig.5. The two series connected MOSFET's from the three port bi-directional AC-DC converter is modified

using a single MOSFET switch with four reverse blocked diodes and the performance is noted with simulation results. The whole circuit remains the same except the two series connected MOSFET's are replaced by the single MOSFET and four diodes. In this type of switching arrangement, as the number of switches is reduced, the switching losses also get reduced for the modified three port bi-directional AC-DC converter.

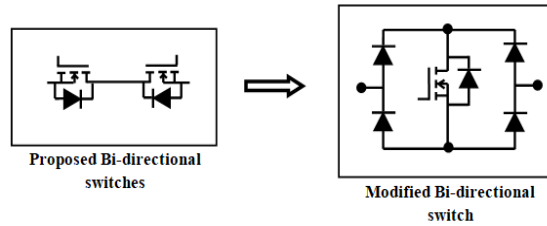

Fig.5. Switching arrangement for direct DC power port of three port converter.

III.CONTROL CIRCUIT DIAGRAM:

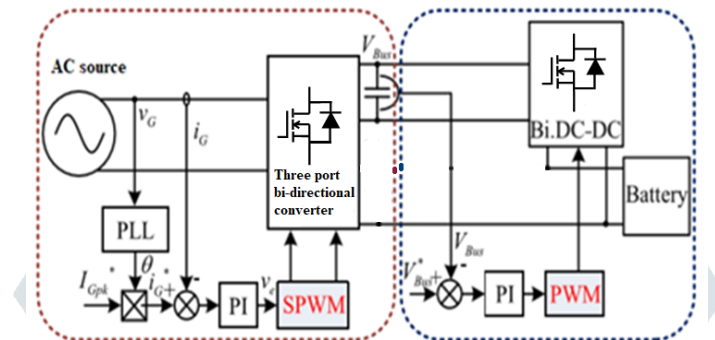

Fig.6. Control circuit diagram for three port bi-directional AC-DC converter

The control circuit diagram of the three port bi-directional AC-DC converter as shown in fig.6 consists of two isolated control loops. For DC bus voltage control, bi-directional DC-DC converter is responsible. For that, a simple control loop is provided and for AC current regulation three port bi-directional converter control loop is responsible. It generates a modulation signal based on error of the AC current and from the modulation signal, PWM pulses are generated.

Here PI controllers are used in voltage control loops and supply current control loop. In this, the reference voltage/current is compared with the measured voltage/current and the error signal is provided to the PI controllers. The PI controller will generate duty ratio/modulation signal which is given to pulse generation units which will generate pwm pulses and provided to the DC-DC converter/bridge converter.

The steps for tuning of PI controllers are provided below:

- Begin with only proportional controller.
- Provide the gain value K_p as minimum.

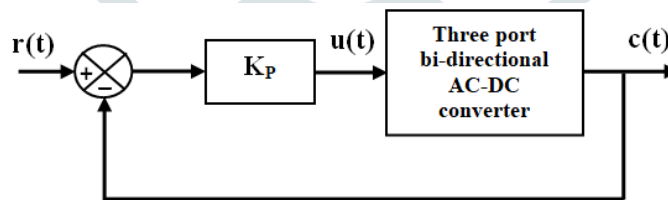

- Increases the proportional gain K_p until the outputs reached steady state conditions and note the gain value as K_{cr} .

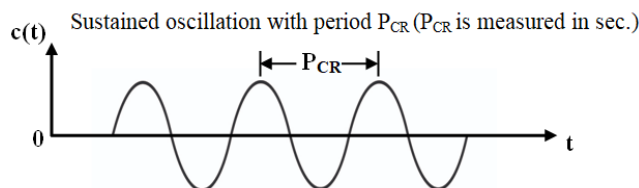

- Calculate the proportional and integral gains as per the following table:

Type of controller	K_p	T_i	T_d
P	$0.5K_{cr}$	∞	0
PI	$0.45K_{cr}$	$\frac{1}{1.2} P_{cr}$	0
PID	$0.6K_{cr}$	$0.5P_{cr}$	$0.125P_{cr}$

- Ziegler-Nichols tuning method is used to get an initial set of PI gains for an unknown system.

DESIGN PROCEDURE FOR THE THREE PORT BI-DIRECTIONAL AC-DC CONVERTER

(i) Voltage gain

$$D = \frac{V_o - V_{in}}{V_o}$$

(ii) Inductance

$$L = \frac{V_b * D}{\Delta I_L * f_s}$$

The inductor ripple current is given below:

$$\Delta I_L = 0.2 * \frac{V_o}{V_{in}} * I_o$$

(iii) Capacitance

$$C = \frac{I_o * D}{\Delta V_c * f_s}$$

The grid source inductance is calculated from the following equations:

$$V_{bus} = \frac{2\sqrt{2}}{\pi} V_g \cos \alpha - \frac{2}{\pi} \omega L I_{bus}$$

IV.SIMULATION SETUP AND RESULTS

The parameters used in the designing of simulation circuit of the three port bi-directional AC-DC converter are given in the following table:

TABLE I.SIMULATION PARAMETERS OF THE THREE PORT BI-DIRECTIONAL AC-DC CONVERTER

PARAMETERS	VALUES
Input source voltage(V _s)	220V, 50Hz
Switching Frequency(f _s)	40kHz
Battery Voltage(V _B)	160V, 5Ah, 80% SOC
Load Resistance(R)	100Ω
Source Inductance (L _s)	0.25mH
Inductor (L)	1mH
Capacitor (C)	10μF

The simulation circuit is drawn in the MATLAB/simulink model of the three port bi-directional AC-DC converter. The simulation circuit of three port bi-directional AC-DC converter is shown in fig.7.

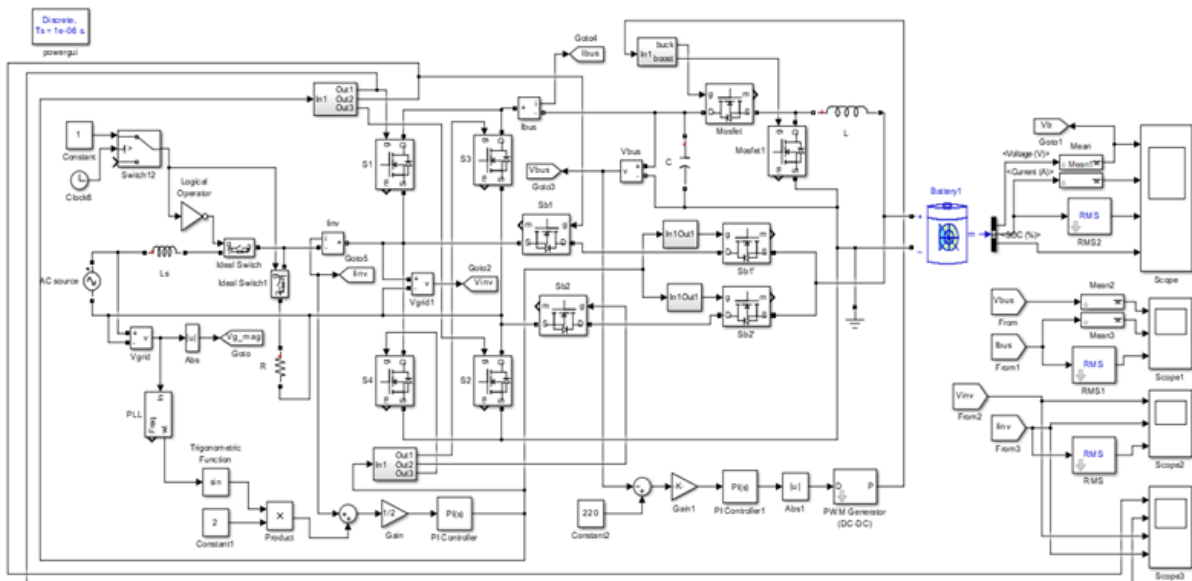

Fig.7. Simulation circuit of the three port bi-directional AC-DC converter

The rectification mode of operation is set from 0sec to 0.5sec (i.e., X-axis) and the inversion mode of operation is set from 0.5sec to 1sec (i.e., X-axis), so that we can observe both the rectifying and inverting operations together.

The battery voltage, battery current, RMS value of the battery current and %SOC (state of charge) of the three port bi-directional AC-DC converter is provided in the following waveform shown in the scope:

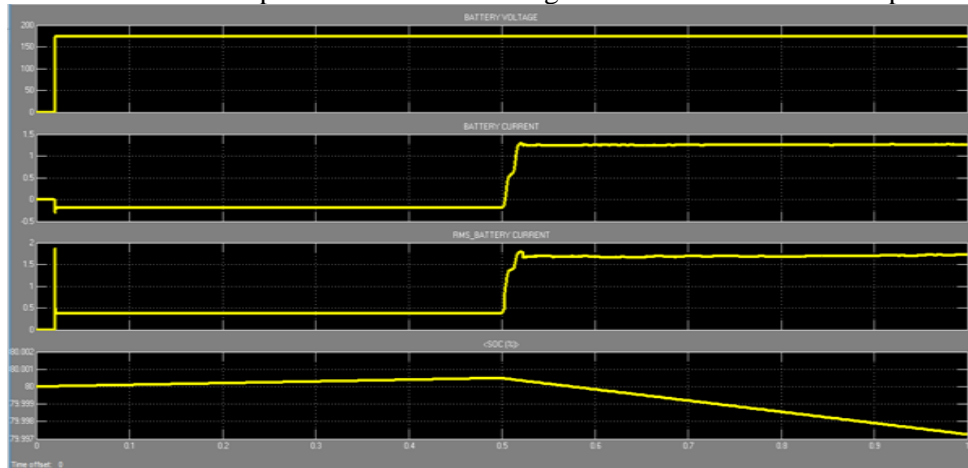

Fig.7 (a).Simulation waveforms of battery voltage, battery current, RMS battery current and %SOC of the three port bi-directional AC-DC converter

When the converter operates in rectifying mode, the battery gets charged and when it operates in inverting mode, the battery gets discharged as observed in the fig.7 (a). The battery output voltage is 175Volts. The RMS value of the battery current is taken to know the flow of current. The %SOC is the state of charge of the battery during charging and discharging.

The DC bus voltage, DC bus current and RMS value of the DC bus current of the three port bi-directional AC-DC converter is provided in the following fig.7 (b) shown in the scope:

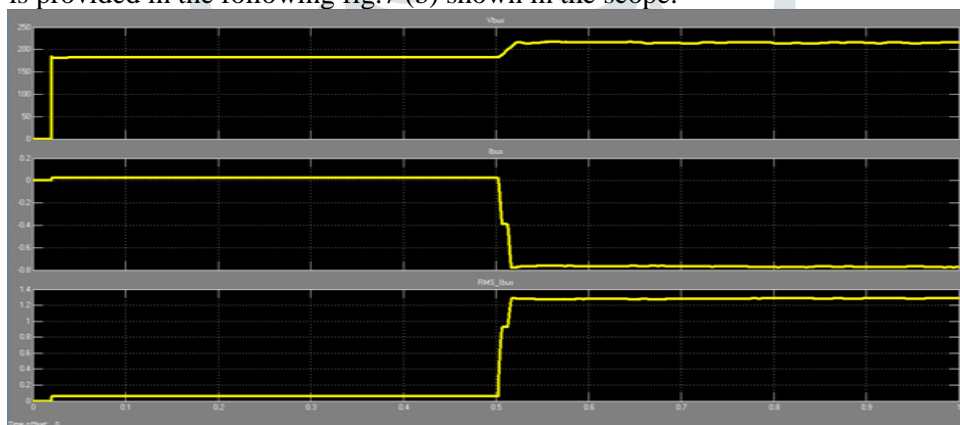

Fig.7 (b).Simulation waveforms of DC bus voltage and current of the three port bi-directional AC-DC converter

The DC bus voltage is required to maintain a constant voltage near to the input source voltage of 220Volts for both rectifying and inverting mode of operation. The DC bus current is negative in inverting mode because of the fact that the current is flowing in the opposite direction, hence the RMS value of the DC bus current is obtained as shown in fig.7 (b).

The gate pulses provided to switch S_{b1} and switch S_1 and the inverter voltage and current of the three port bi-directional AC-DC converter are provided in the following waveforms fig.7 (c) shown in the scope:

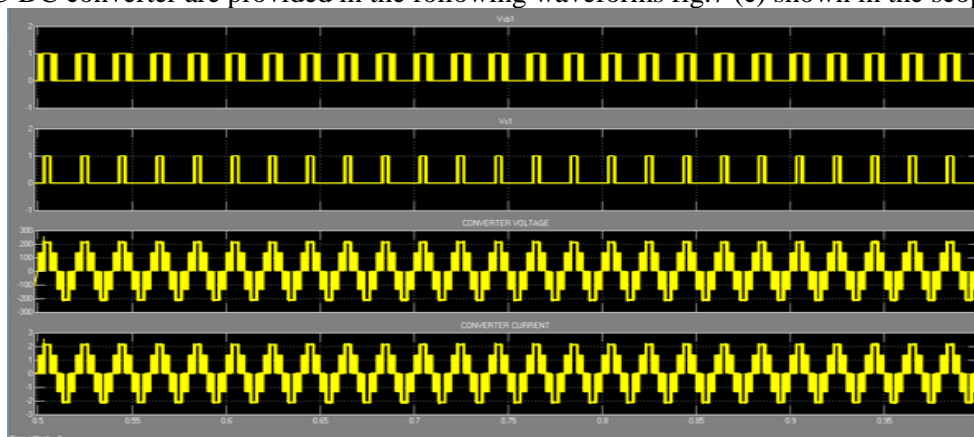

Fig.7 (c).Simulation waveforms of the pulses provided to switch S_{b1} and S_1 , inverter voltage and current

The AC converter voltage, converter current, RMS value of the converter current of the three port bi-directional AC-DC converter is provided in the following fig.7 (d) shown in the scope:

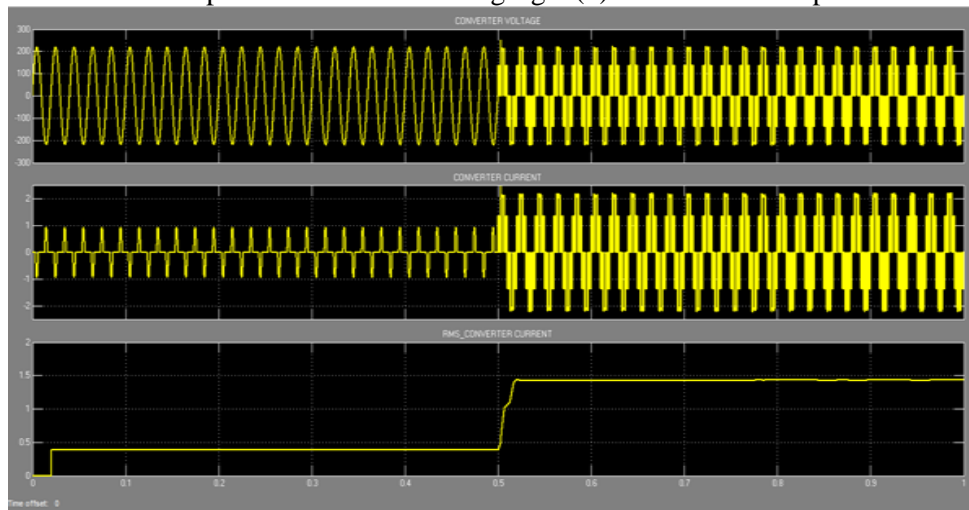

Fig.7 (d).Simulation waveforms of AC converter voltage, converter current and RMS converter current of the three port bi-directional AC-DC converter

In the rectifying mode voltage and current are opposite in phase while in inverting mode both the voltage and current phases will be same as observed in the fig.7 (d). In the inverting mode a battery of 160Volts is the source, thus the output appears in steps as the power processing stages reduces, the first level indicates the power processing through the DC power port up to 160Volts and the second level indicates the power processing through the DC-DC converter which boosts the voltage upto 220Volts.

In the three port bi-directional AC-DC converter, the bi-directional switches has two series connected MOSFET's. Therefore, these bi-directional switches are modified by only a single MOSFET switch and four diodes. The connection arrangement of the MOSFET switch replacing two MOSFET switches is shown in fig.8.

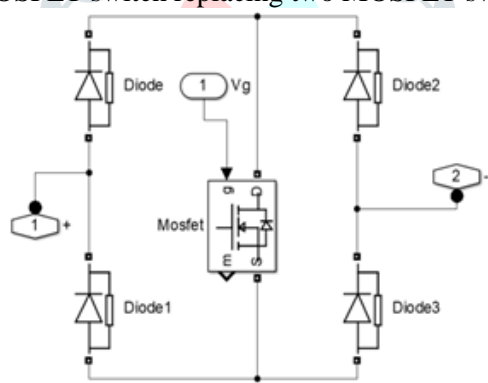

Fig.8. Sub-module of modified MOSFET switch

The simulation system of the modified three port bi-directional AC-DC converter is shown in fig.9 with single MOSFET switch.

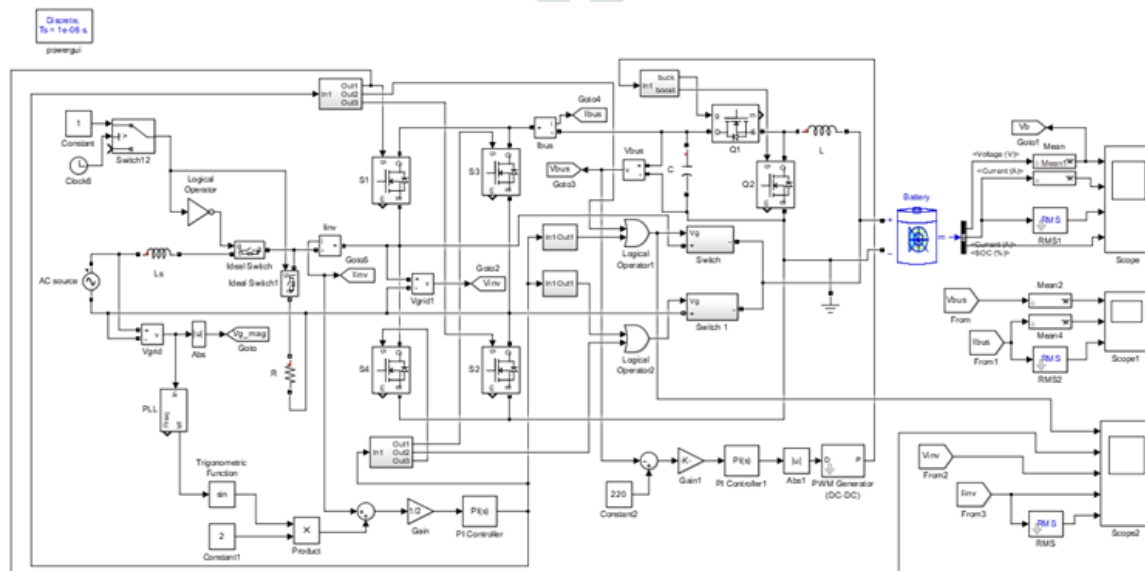

Fig.9. Simulation circuit of the modified three port bi-directional AC-DC converter

The AC converter voltage, converter current, RMS value of the converter current along with the gate pulses provided to switch S_{b1} and switch S_1 of the modified three port bi-directional AC-DC converter is provided in the following fig.9 (b) shown in the scope:

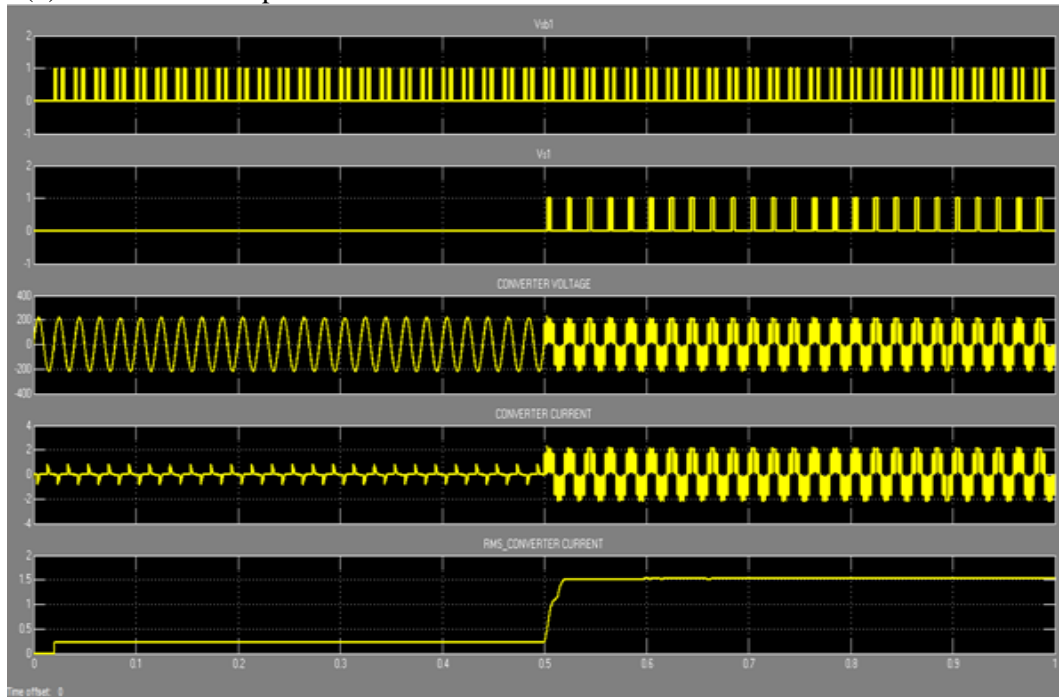

Fig.9 (b).Simulation waveforms of AC converter voltage, current and RMS value of the modified three port bi-directional AC-DC converter

In the rectifying mode voltage and current are opposite in phase while in inverting mode both the voltage and current phases will be same as observed in the fig.9 (b). In the inverting mode a battery of 160Volts is the source, thus the output appears in steps as the power processing stages reduces, the first level indicates the power processing through the DC power port up to 160Volts and the second level indicates the power processing through the DC-DC converter which boosts the voltage upto 220Volts.

V.ADVANTAGES AND APPLICATIONS

ADVANTAGES OF THE THREE PORT BI-DIRECTIONAL AC-DC CONVERTER:

1. The charging and discharging of the battery is done by both direct DC power port and through bi-directional DC-DC buck-boost converter and thereby reducing the power processed by DC-DC buck-boost converter and hence reducing the switching losses.
2. The power rating of the DC-DC buck-boost converter in the three port bi-directional AC-DC systems are reduced significantly.
3. The switching losses are further reduced by reducing the number of switches in direct DC port by using the modified three port bi-directional AC-DC converter with a single MOSFET switch and four reverse blocked diodes.

APPLICATIONS OF THE THREE PORT BI-DIRECTIONAL AC-DC CONVERTER:

1. It can be used in uninterruptable power supply (UPS).
2. Three port bi-directional AC-DC converter is used in renewable energy applications.
3. It also can be used in charging stations of electric vehicles as it can operate under both grid to vehicle and vehicle to grid modes.
4. Three port bi-directional AC-DC converter is used for battery energy storage applications.

VI.CONCLUSION

A new three port bidirectional converter is proposed for battery energy storage applications. Here, the charging and discharging of the battery is done by both direct DC power port and through bi-directional DC-DC converter and thereby reducing the power processed by DC-DC converter and hence reducing the switching losses. The switching losses are further reduced by reducing the number of switches in direct DC power port by using the modified three port bi-directional AC-DC converter with a single MOSFET switch and four reverse blocking diodes. The three port bi-directional AC-DC converter is tested in both forward mode with AC source as supply and battery as load, and reverse mode with battery as the supply and an R as the load respectively. The three port bi-directional converter circuit is investigated using MATLAB/simulink software R2014a version. With the simulation results, it is observed that the three port bi-directional AC-DC converter provides better performance with reduced power processing stages and minimum switching losses.

REFERENCES

- 1) Hong feiWu , Lei Zhu, and Fan Yang, "Three-Port-Converter-Based Single-Phase Bidirectional AC–DC Converter With Reduced Power Processing Stages and Improved Overall Efficiency," *IEEE Trans. Power Electronics*, vol. 33, no. 12, Dec. 2018.
- 2) E. Chatzinikolaou and D. J. Rogers, "A comparison of grid-connected battery energy storage system designs," *IEEE Trans. Power Electronics*, vol. 32, no. 9, pp. 6913–6923, Sep. 2017.
- 3) N. Tashakor, E. Farjah, and T. Ghanbari, "A bidirectional battery charger with modular integrated charge equalization circuit," *IEEE Trans. Power Electronics*, vol. 32, no. 3, pp. 2133–2145, Mar. 2017.
- 4) H. Wu, K. Sun, L. Chen, L. Zhu, and Y. Xing, "High step-up/step-down soft-switching bidirectional dc-dc converter with coupled-inductor and voltage matching control for energy storage systems," *IEEE Trans. Ind. Electronics*, vol. 63, no. 5, pp. 2892–2903, May 2017.
- 5) S. Hu, Z. Liang, and X. He, "Ultracapacitor-battery hybrid energy storage system based on the asymmetric bidirectional Z-source topology for EV," *IEEE Trans. Power Electronics*, vol. 31, no. 11, pp. 7489–7498, Nov. 2016.
- 6) M.S.Agamyetal,Maja Harfman-Todorovic, Ahmed Elasser, Song Chi, Robert L. Steigerwald, Juan A. Sabate, Adam J. McCann, Li Zhang, and Frank J. Mueller, "An efficient partial power processing dc/dc converter for distributed PV architectures," *IEEE Trans. Power Electronics*, vol. 29, no. 2, pp. 674–686, Feb. 2014.
- 7) Z. Liu, B. Li, F. C. Lee, and Q. Li, "High-efficiency high-density critical mode rectifier/inverter for WBG-device-based on-board charger," *IEEE Trans. Ind. Electronics*, vol. 64, no. 11, pp. 9114–9123, Nov. 2017.
- 8) H. Wu, M. Han, and Y. Zhang, "Three-port rectifier-based ac-dc power converters with sigma architecture and reduced conversion stages," *IEEE J. Emerging Sel. Topics Power Electronics*, vol. 5, no. 3, pp. 1091–1101, Sep. 2017.

