

MONITORING OF HUMAN BODY PARAMETERS USING WEARABLE WIRELESS SENSOR NETWORK

Harshal S Yeotkar¹, Dr. V. T. Gaikwad²

¹M. E. Student, Electronics & Telecommunication Dept., Sipna COET, Amravati, Maharashtra, India.

²Professor, Electronics & Telecommunication Dept., Sipna COET, Amravati, Maharashtra, India.

Abstract: - Remote monitoring technique that could precisely monitor human body parameters is useful in applications such as medical science, sports science, rehabilitation, virtual reality and surveillance. Most of the existing systems used for monitoring human body parameter require wiring that restrains the natural movement. To overcome this limitation, a wearable wireless sensor network using Accelerometer, Pulse Oximeter and Heart-Rate Sensor, Temperature sensor and Galvanic Skin Response sensor have been developed for monitoring physiological human body parameters. The person is wirelessly monitored with his own location. This system can be easily adapted to monitor athletes and infants. The wireless feature enables the unrestrained motion of the human body as opposed to a wired monitoring device and makes the system truly portable, fast and reliable. The lightweight and compact size of the developed sensor node makes it easy attachment to the body.

Index Terms - *Wireless Sensor Network, Accelerometer, Temperature sensor, Pluse Oximeter & Heart rate sensor, Galvanic Skin Response sensor, Internet of Things.*

1. INTRODUCTION

Tracking of human body parameters has attracted significant interest in recent years due to its wide-ranging applications such as rehabilitation, virtual reality, sports science, medical science, surveillance, in recent times, wireless sensors and sensor networks have become a great interest to research, scientific and technological community. Though sensor networks have been in place for more than a few decades now, the wireless domain has opened up a whole new application space of sensors. Wireless sensors and sensor networks are different from traditional wireless networks as well computer networks and, therefore, pose more challenges to solve such as limited energy, restricted life time, etc.

The objective is to allow the person to be monitored in a natural environment. For monitoring outside the laboratory, a wearable system must not only display the parameters but also record the data; the proposed approach uses the wireless sensor network concept with all the sensor nodes communicated to the coordinator wirelessly using Wi-Fi network protocol. The coordinator acts as a router which makes connectivity between sensor nodes and end device via internet, end device may be computer or mobile. Each sensor node is may equipped with accelerometer, temperature sensor, pulse oximeter SpO2 & heart-rate sensor and galvanic skin response sensor. The sensor nodes are attached to the human body and operate completely untethered. They are powered by battery. The small form factor and lightweight feature of the sensor nodes allow easy attachment to the body.

2. LITERATURE REVIEW

An important component of ubiquitous healthcare is wireless sensor network (WSN). WSNs are an emerging technology that is poised to transform healthcare. The WSNs promise to make life more comfortable by significantly improving and expanding the quality of care across a wide variety of settings and segments of the population. This paper provides a brief introduction on applications of wireless sensor networks in healthcare [1]. This paper reviews the various types of wireless technologies used for medical applications such as WLAN, WPAN, WIMAX and WBAN and states their frequency, range standard etc., These wireless technologies are compared based on the factors such as energy consumption, security, routing protocols in order to increase the efficiency and effectiveness of the monitoring system [2]. In parallel to WSNs, the idea of internet of things (IoT) is developed where IoT can be defined as an interconnection between identifiable devices within the internet connection in sensing and monitoring processes [3]. Measurement of Elder Health Parameters and the Gadget Designs for Continuous Monitoring Improving the quality of life for the elderly persons and giving them the proper care at the right time is the responsibility of the younger generation a simple, compact and user-friendly electronic gadget for continuous monitoring of elder health parameters is the need of the hour. Day by day the menace of weakening health and chances of skin related problems, bed sores etc are becoming critical in case of bed ridden patients. This paper analyses the old age diseases and the parameters to be monitored [4]. A Zigbee-Based Wearable Physiological Parameters Monitoring System can be used to monitor physiological parameters, such as temperature and heart rate, of a human subject. The system consists of an electronic device which is worn on the wrist and finger, by an at-risk person. Using several sensors to measure different vital signs, the person is wirelessly monitored within his own home. An impact sensor has been used to detect falls. The device detects if a person is medically distressed and sends an alarm to a receiver unit that is connected to a computer. This sets off an alarm, allowing help to be provided to the user [5]. Technology which is well into existence and reduces cost of electrical wiring and uses the already available power line wires known as the power line communication. The intent of this work is to send the biomedical parameters like the heart rate, respiration rate and body temperature through PLC system [6] Some of the elder care systems as mentioned in [7] monitor activities of the elders in their home. They embed a video system in the living environment of elders and continuously monitor their activities at home. However, this system doesn't measure any of the vital parameters of the elderly patient. Measuring the vital parameters is inevitable if the elder person suffers from any sort of heart ailments, which are very common in individuals aged above 60 [8]. In mobile devices like Calyx (Complete Ambient Assisted Living Experiment) which can measure vital signs like ECG, pulse, Blood pressure,

Movement and Fall detection. However, the design we have proposed can monitor vital parameters and fall detection along with tilt monitoring for the bed-ridden patients to monitor any case of bedsores. Some devices as in [9] monitor only fall detection for the elderly patients based on the sensor readings from accelerometers and microphones attached to the body of the patients. The system proposed in [10] is applicable to patients and elders for activity monitoring and fall detection and also sports athletes exercise measurement and pattern analysis. [11] A wearable wireless sensor network using accelerometers has been developed in this paper to determine the arm motion in the sagittal plane. The system provides unrestrained movements and improves its usability. The lightweight and compact size of the developed sensor node makes its attachment to the limb easy. Experimental results have shown that the system has good accuracy and response rate when compared with a goniometer.

3. SYSTEM DESIGN ARCHITECTURE

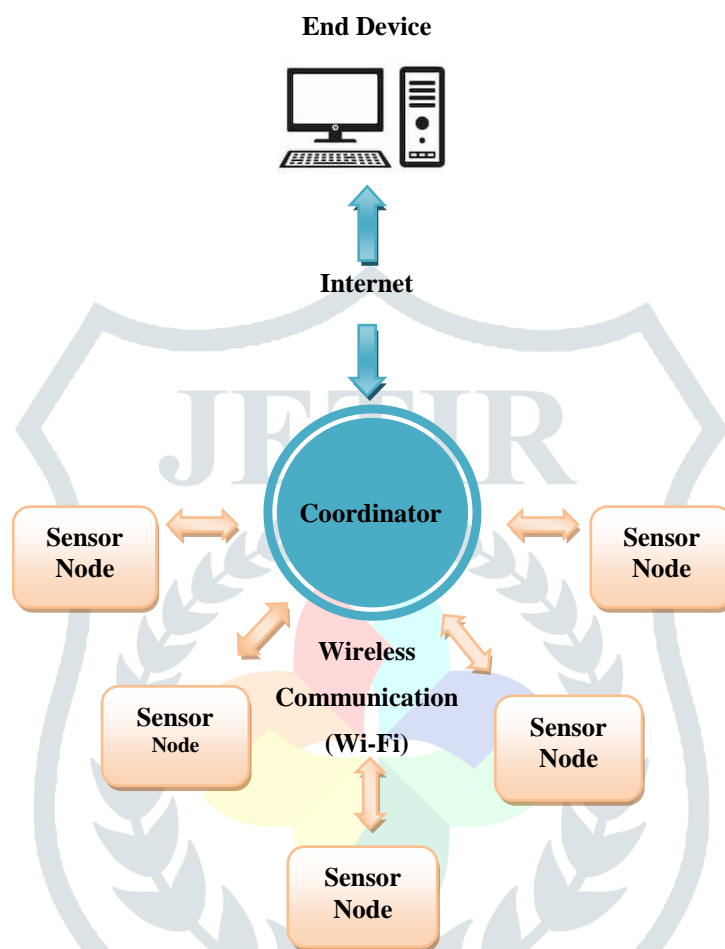

Fig. 1: General Configuration of the System

Fig. 1 shows the configuration of the system. It is observed that the system consists of a number of sensor nodes that wirelessly communicate to a central coordinator in a star network topology. Wireless sensor network is a promising field that integrates sensor technologies, embedded system and wireless communication together to produce small, low cost, low power and reliable system capable of monitoring specific events. For this system, wireless protocol suite used because it provides end-to-end connectivity. The coordinator acts as a router which makes connectivity between sensor nodes and end device via internet, end device may be computer or mobile. Each sensor node is may equipped with accelerometer, temperature sensor, pulse oximeter SpO2 & heart-rate sensor and galvanic skin response sensor. The sensor nodes are attached to the human body and operate completely untethered. They are powered by battery.

4. FUNCTIONAL BLOCK DIAGRAM OF SYTEM DESIGN

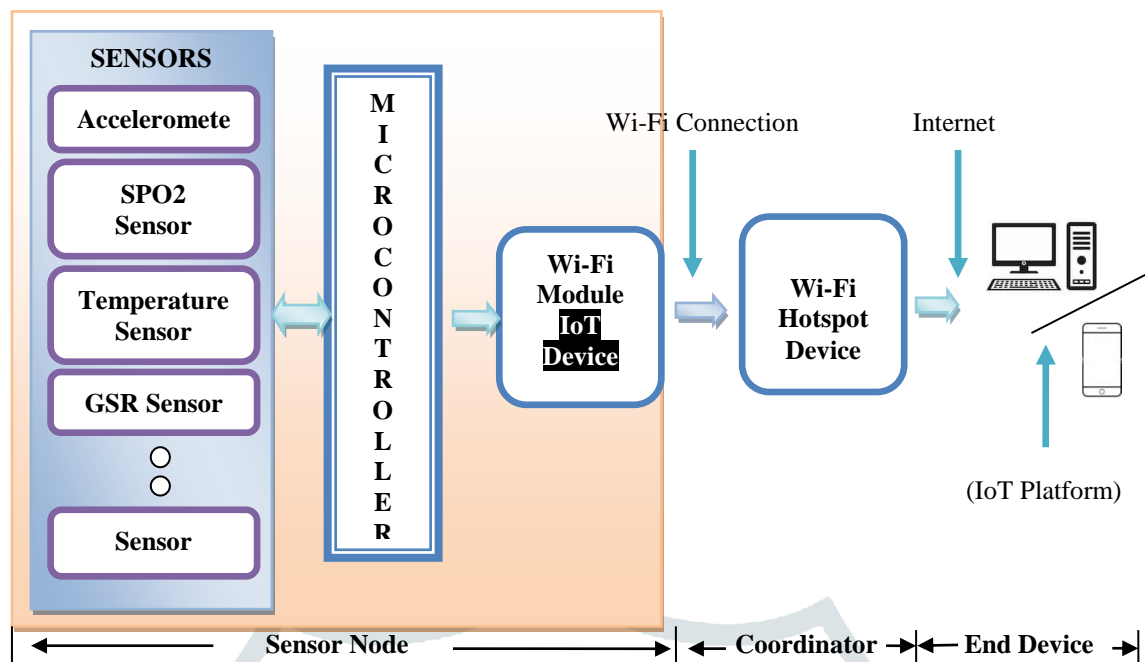

Figure 2: Functional block diagram of the system

Figure 2 shows the functional block diagram of the system. The system has been designed to take several inputs from sensors to measure physiological parameters of human body such as temperature sensor for body temperature, SPO2 sensor for monitoring of Heart rate and Blood Oxygen level, Accelerometer that can be either used to detect body position, muscle movement and motion, Galvanic skin response sensor to measure skin response. The inputs from the sensors are integrated & processed by microcontroller, then microcontroller send processed data to Wi-Fi IoT device. The IoT device forward received data from microcontroller towards the end device with the help of coordinator via internet and finally we can monitor all the parameters on IOT platform running on the end device, which is computer or mobile. The coordinator acts as a router and it may be Wi-Fi Mobile or Modem. Once the sensor node has connected to the host computer, data is automatically updated on the IoT platform (Thinger.io). The design is modular which makes it rather easy and straight forward to add extra sensors for measuring and monitoring other parameters.

Sensors and their positioning at human body:

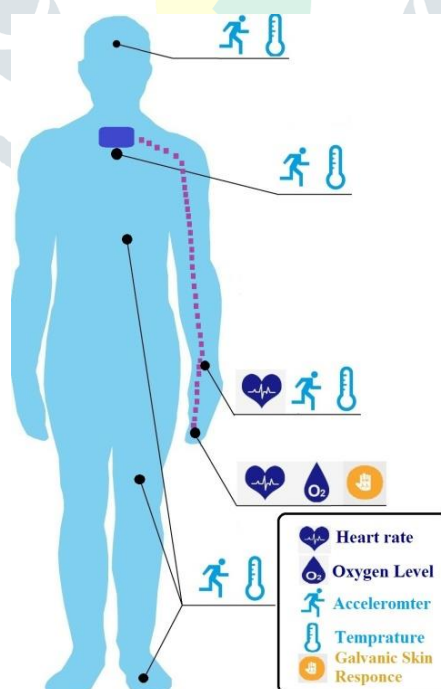

Fig. 3: Various sensors and their placement on human body

Above figure shows that the Placement of sensor node and wearable sensors like Accelerometer, Temperature, Pulse Oximeter SpO2 & Hart rate, Galvanic Skin Response on Human body.

4.1 PARAMETERS TO BE MONITORED

Body Temperature:

Body temperature is a basic parameter, which has to be monitored in any individual. Body temperature sensor fixed at a particular location of body measures the temperature and transmits the value to the main coordinator.

During exercise, the body temperature is not only one of the most important physiological indicators, but indicators can also be used to determine the signs of heat and heat stroke. If the body temperature reaches 40 °C, heat stroke may occur, so that monitoring of body temperature is essential during exercise.

Variety of accidents caused by physical stress due to a lack of thermo regulation. Nowadays, due to globalization, athletes repeatedly demand maximum performances from their body under sometimes extreme climatic circumstances. Although in sports science it is already for a long time known that body temperature is an important factor during the training and competition process Humans, as homeothermic (warm-blooded) beings, have a constant operating temperature in a tolerance range of 37 °C} 0.5 °C in the core body.

Body Postural & Movements:

Monitoring the movements of the human body is of great importance in various application fields including medicine, physical exercise and sport.

It is important to monitor activity and movement for physical therapists to understand the detect motion with inertial sensors for balance and gait assessment and treatment in rehabilitation.

By combining multiple types of A 3-axis accelerometer can be used together to create a convenient device for use in outdoor activities such as adventure sports.

Another serious issue related to Elders is fall detection. Falls can be markers of poor health and declining function, and they are often associated with significant morbidity. More than 90 percentages of hip fractures occur as a result of falls, with most of these fractures occurring in persons over 70 years of age. Monitoring of bed ridden elders thus becomes very crucial issue in maintaining proper health condition. Thus it requires that the caretaker to monitor the elder at regular intervals. If the caretaker fails to keep track of the elder posture it could lead to a case of bedsores. Thus a system is necessary to keep track of the elder posture continuously and assist the caretaker in taking timely action in order to avoid the cases of bedsores.

Heart rate and Blood Oxygen level:

Heart rate is another basic important parameter of a human. High blood pressure, or hypertension, is commonly linked to conditions such as heart attacks and stroke

In Sports heart-rate monitors have been widely used by professional trainers as well as club-level athletes and enthusiasts in cardiovascular sports such as running, swimming, and cycling help to improve sport performance.

Blood oxygen saturation is a measure commonly used by healthcare professionals to check for conditions such as anemia or correct operation of the heart.

A poorly pumping heart is major issue in elderly community. The overall activeness of heart reduces since all the nerves and arteries get weaker. More than 83% of the people who die of heart disease are older than 65 years. So, it is compulsory required to include the heart rate monitoring.

Galvanic Skin Response:

The GSR sensor measures changes in the surface resistance of the skin by releasing a current to the human body whereas the skin resistance (G) depends on the skin humidity, vasoconstriction and relaxation, the thickness of the stratum corneum, and chemical substances. So, when a person's mood changes or they feel discomfort, then the skin resistance value decreases. Therefore we used the rate of change of GSR as the evaluation index for heat stroke, also it is used as a measurement of anxiety, which in turns can be used in lie detection

4.2 Wireless Sensor Network & Selection of Network

WNS is a promising field that integrates sensor technologies, embedded system and wireless communication together to produce small, low cost, low power and reliable system capable of monitoring specific events. The IEEE standard 802.11.a/b/c is developed targeting specifically for this application domain. It has been used in a variety of applications including commercial and industrial monitoring, home automation and networking, consumer electronics, personal computer peripherals, home security, personal healthcare, toys and games, automotive sensing, agriculture etc.

The communication between sensor node and coordinator unit is wireless, data from the sensor node is monitor on IoT platform at the internet accessed host computer by building a network between the sensor node and the coordinator unit, for that communication Wi-Fi wireless network technology is used. in our system design Wi-Fi Technology take into account because it is commonly used for the wireless local area networking (WLAN) of devices which is based around the IEEE 802.11 family of standards Wi-Fi uses multiple parts of the IEEE 802 protocol family and is designed to seamlessly interwork with its wired sister protocol Ethernet

Devices that can use Wi-Fi technologies include desktops and laptops, smart phones and tablets. Compatible devices can connect to each other over Wi-Fi through a wireless access point as well as to connected Ethernet devices and may use it to access the Internet. Such an access point (or hotspot) has a range of about 100 meter greater range, high data rate up to 55Mbps and having node per network connectivity up to 30 node. Table 1 shows that the Comparison of Wireless Technologies,

Table 1: shows that Comparison of various Wireless Technologies

Wireless Parameters	Blue tooth	Home RF	802.11 Wireless LAN	ZigBee	Wi-Fi
IEEE Connection Type	802.15.1	Alternative Of IEEE 802.11	802.15.1	802.15.4	802.11.a/b/c
Frequency Spectrum	2.4 GHz	2.4 GHz	2.4 GHz	868/915Mhz,2.4G Hz	2.4Ghz-5GHz
Data Rate	1Mbps	1Mbps, 2Mbps	1Mbps, 2Mbps	250Kbps	54Mbps
Node Per Network	7,8	127		64K	30
Rang	10 Meter	Typical home	100Meter	10 -100Meter	100Meter
Network Topology	Ad-hoc, Small network		Ad-hoc, Peer to Peer	Ad-hoc, Peer to Peer, Star Or Mesh	Point to Hub
N/W joint time	>3Sec	Variable	>30ms	>30ms	Variable, 1Sec Typically
Application	Wireless device Connection	High Quality Vice Channel	Small in-home networks to large school, campus, office building etc	Industrial Control & Monitoring sensor N/W, Bulinding Automation, Toys & Game	Wire Less LAN, Internet access

5. SYSTEM DESIGN CONFIGURATION

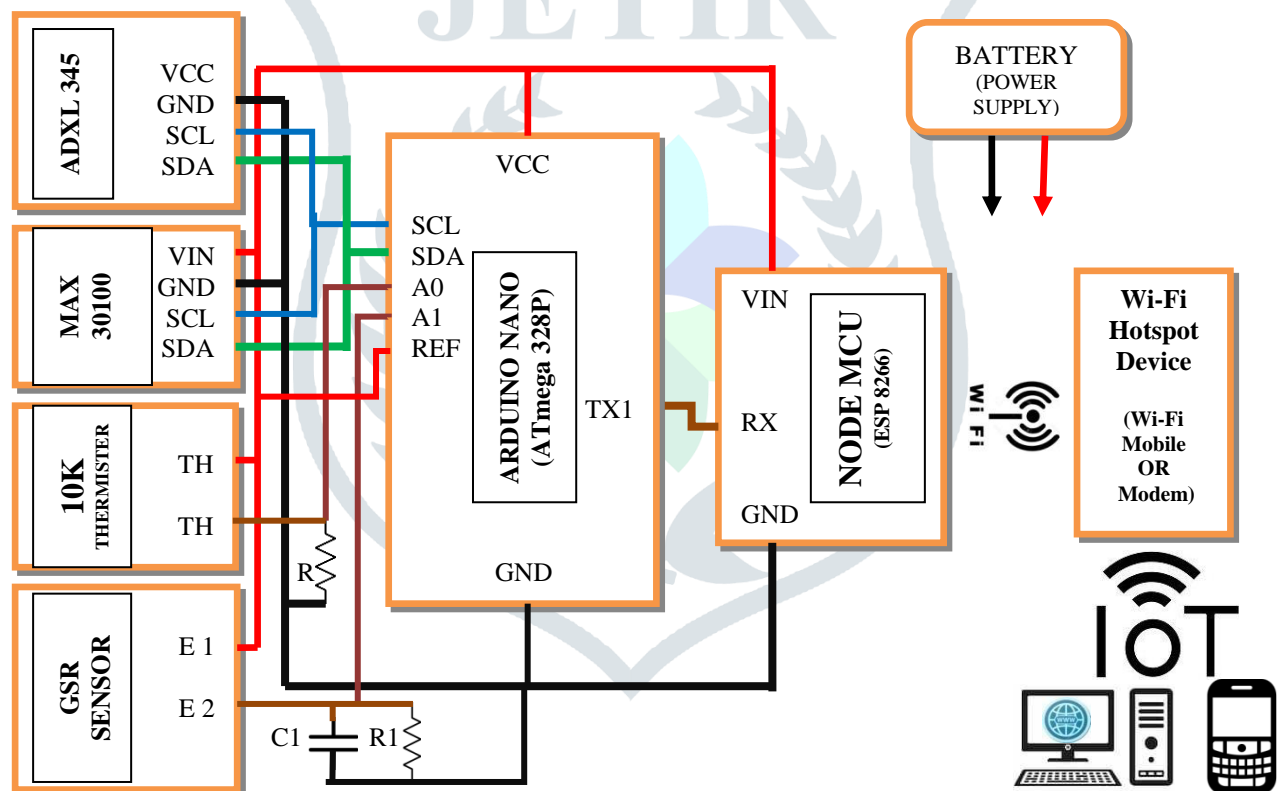

ig.4: Configuration of the system (Circuit Configuration of Sensor Node)

The configuration of the system shown in the Fig. 4, it is observed that the system consists of number of sensors that are Accelerometer ADXL 345 for detection of postural & motion of body in terms of tilt angle of up to three axes, SPO2 MAX30100 for detection of hart rate & blood oxygen level, 10K thermistor for temperature detection and GSR for skin resistance measure. All these sensors communicate to arduino nano board with two to four wire connections. The aduino nano board module contains ATmega328 Microcontroller, out of the sensors in the system the accelerometer ADXL345 and SPO2 MAX 30100 sensor module are digital sensors, so that ADXL345 & MAX 30100 sensor module communicate with microcontroller by Inter Integrated Circuit(I2C: SCL, SDA) logic. Whereas thermister and GSR sensor is the analog sensor therefore they communicate through analog inputs (A0 & A1) lines of the microcontroller. The microcontroller ATmega 328 processes received data from the various sensors and transmit processed data serially to the Node MCU ESP8266 Wi-Fi Module with the help of Tx & Rx line. The Node MCU Wi-Fi connectivity feature allow to made connection with Wi-Fi modem or Mobile phone i.e. Coordinator device of the system. With the help of coordinator node McUESP8266 send all the data to the end device via internet and finally Thinger.io an IoT platform allows monitoring of human body parameters from various sensor nodes on the end device i.e. computer or mobile. The sensor node may use a 5-V rechargeable alkaline battery.

5.1 ABOUT ARDUINO NANO:

The Arduino Nano is a small, complete, and breadboard-friendly board based on the ATmega328 microcontroller (Arduino Nano 3.0), works with a Mini-B USB cable instead of a standard one. The Nano was designed and is being produced by Gravitech.

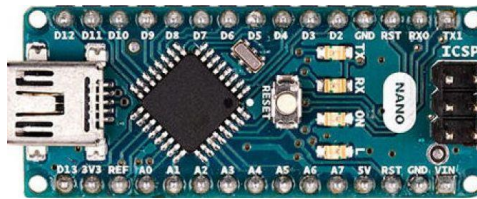

Some Important features are > 32K Bytes of In-System Self-Programmable Flash program memory, 1K Bytes EEPROM , 2K Bytes Internal SRAM, 23 Programmable I/O Lines, 32-lead TQFP, 32-pad QFN/MLF, 1.8 - 5.5V, One 16-bit Timer/Counter with Separate Prescaler, Compare Mode, and Capture Mode, Real Time Counter with Separate Oscillator , Six PWM Channels , 8-channel 10-bit ADC , Programmable Serial USART, Master/Slave SPI Serial Interface, Byte-oriented 2-wire Serial Interface.

5.2 DETAILS OF THE SENSING SYSTEM:

The current version of the system consists of four sensors: an Accelerometer, Pulse Oximeter SpO2 and Heart-Rate Sensor, Temperature sensor and Galvanic Skin Response Sensor. The description of individual sensors follows.

a) Accelerometer ADXL345 Module:

The ADXL345 is a low-power, 3-axis MEMS accelerometer modules with both I2C and SPI interfaces. The Sunrom Breakout boards for these modules feature on-board 3.3v voltage regulation and level shifting which makes them simple to interface with 5v microcontrollers such as the Arduino.

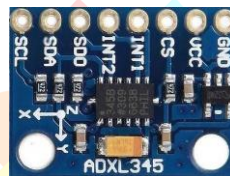

The sensor has three axes of measurements, X Y Z, and pins that can be used either as I2C or SPI digital interfacing. You can set the sensitivity level to either +2g, +4g, +8g or +16g. The lower range gives more resolution for slow movements, the higher range is good for high speed tracking. The ADXL345 is the latest and greatest from Analog Devices, known for their exceptional quality MEMS devices.

b) MAX30100 Pulse Oximeter SpO2 and Heart-Rate Sensor Module:



The MAX30100 is an integrated pulse oximetry and heart rate monitor sensor solution. It combines two LEDs, a photo detector, optimized optics, and low-noise analog signal processing to detect pulse oximetry and heart-rate signals.

The MAX30100 breakout operates from 1.8V and 5.5V power supplies and can be powered down through software with negligible standby current, permitting the power supply to remain connected at all times.

c) NTC Thermistor 10k:

Thermistor is an electronic component used to calculate the temperature. This is a type of resistor whose resistance varies with change in temperature. These NTC thermistors are made up from the combination of metal oxides which passed through sintering process which gives negative electrical resistance versus temperature (R/T) relationship to it. Due to having a large negative slope a small change in temperature cause a huge change in electrical resistance.

d) Galvanic Skin Response (GSR):

The galvanic skin response is a method of measuring the Electrical conductance of skin. GSR, which falls under the umbrella term, of electro dermal activity, or EDA refers to changes in sweat gland activities that are reflective of the intensity of our emotional state, otherwise known as emotional arousal.

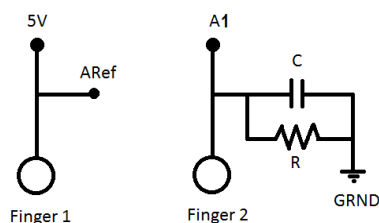

To measure electro dermal activity (EDA) using an Arduino board is straight forward, by inducing voltages through one electrode, an electrical output is measured using a second electrode. The higher the measured value is, the higher the EDA

5.3 ABOUT NODE MCU ESP8266 ESP-12E WIFI BOARD:

NodeMCU is an open source IoT platform. It includes firmware which runs on the ESP8266 Wi-Fi SoC from Espressif Systems, and hardware which is based on the ESP-12 module. The term “NodeMCU” by default refers to the firmware rather than the DevKit.



ESP8266 is a system-on-chip (SoC) which integrates a 32-bit Tensilica microcontroller; standard digital peripheral interfaces, antenna switches, RF balun, power amplifier, and low noise receive amplifier, filters and power management modules into a small package. It provides capabilities for 2.4 GHz Wi-Fi (802.11 b/g/n, supporting WPA/WPA2), general-purpose input/output (16 GPIO), Inter-Integrated Circuit (I²C), analog-to-digital conversion (10-bit ADC), ESP8266.net — The Internet of Things with ESP8266 UART (on dedicated pins, plus a transmit-only UART can be enabled on GPIO2), and pulse-width modulation (PWM).

6. SOFTWARE DEVELOPMENT:

The program is written in ‘C’ language. It is compiled and programmed (upload) into the target device/board using Arduino integrated development environment (IDE). Arduino IDE is a cross-platform application (for Windows, macOS, Linux) that is written in the programming language Java. It is used to write and upload programs to Arduino compatible boards, but also, with the help of 3rd party cores, other vendor development boards.

In our system design software two source code i.e sketches in term of Arduino need to develop one is for the main Microcontroller unit that is Arduino nano board and other is for Wi-Fi module is called Node McU. The program flow chart show in below figures.

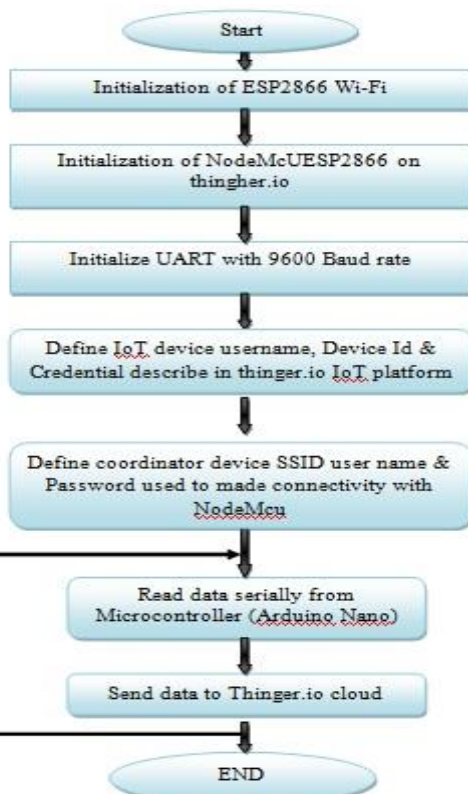

Fig. 5: Program Flow chart for NodeMCU Wi-Fi board

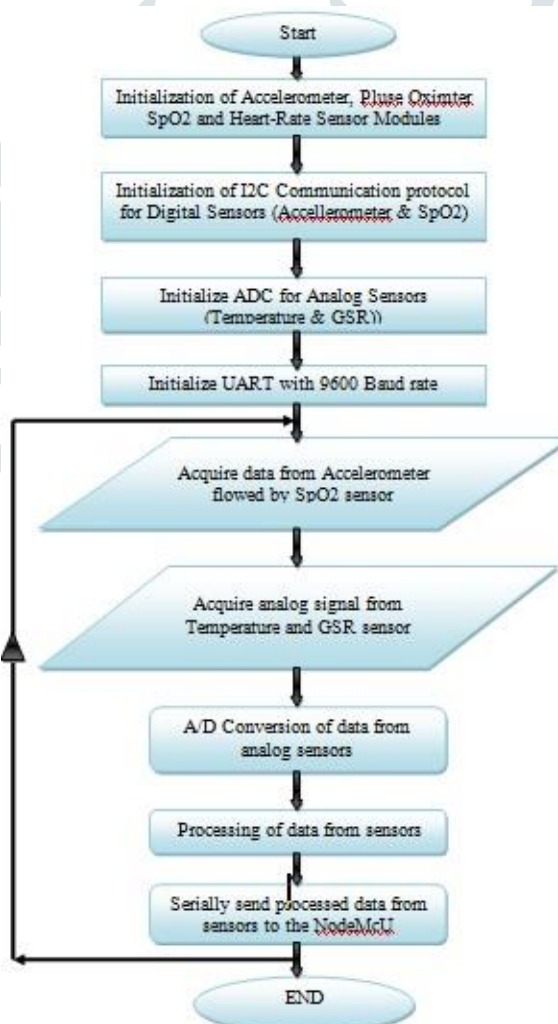

Fig. 6: Program Flow chart for Arduino Nano (µC-ATmega328)

7. RESULTS AND DISCUSSION

To see the result, that means monitoring of human body parameters from wearable wireless sensor nodes, we have use here Thingier.io platform, it is an Open Source platform for the Internet of Things, it provides a ready to use scalable cloud infrastructure for connecting things. First visit <http://thingier.io> website, create a login account and manage different elements of the platform, like devices, dashboard, data buckets, endpoints, or access tokens.

Following figures shows that different screen shots of result which displays real-time body parameters in the form of text values and graphical format.

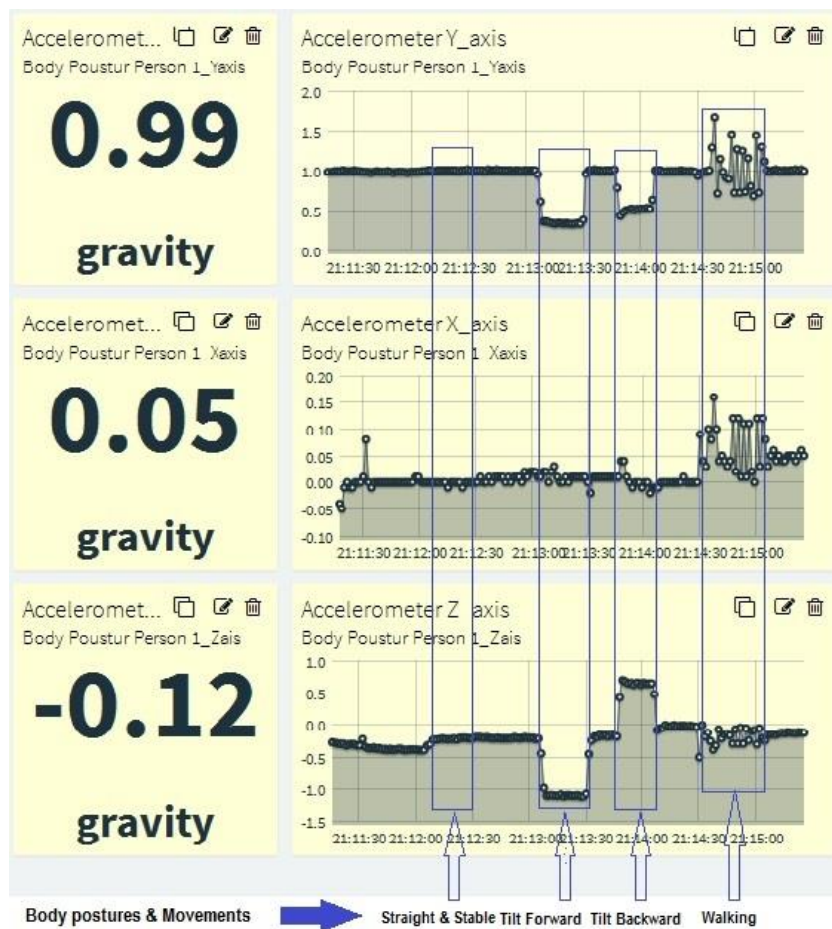
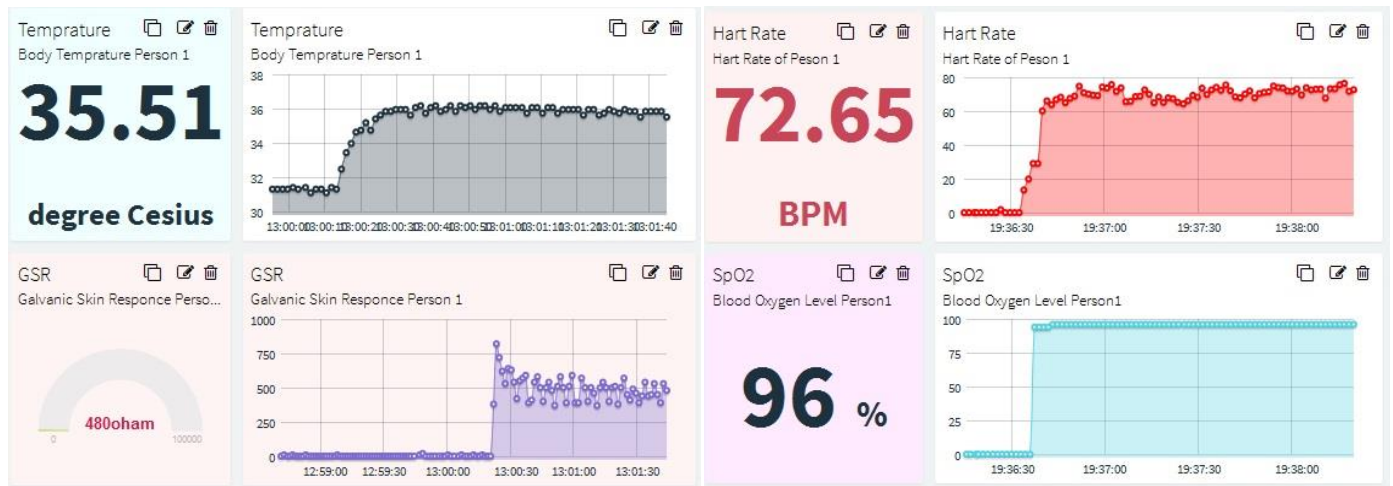

Fig.7: Widget for various parameters of sensor node 1(Person 1)



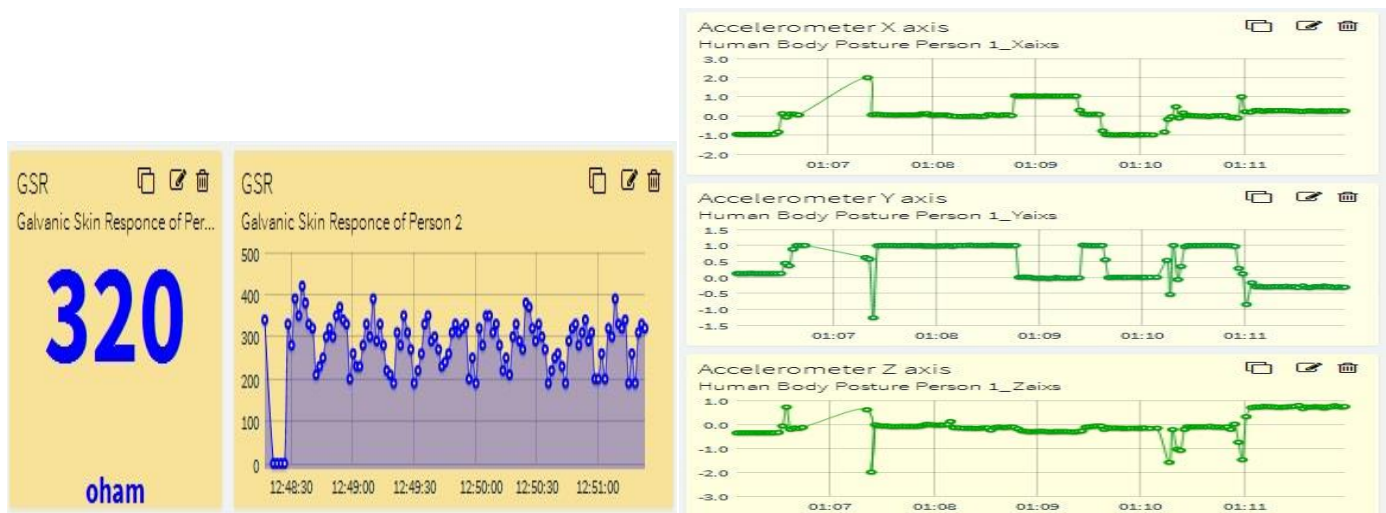

Fig.8: Widget for various parameters of sensor node 2(Person 2)

Figure 7 & 8 shows the screen shots of widget created for sensor node1 and node2 respectively on a thinger.io cloud platform, which allows monitoring of real time human body parameters that are Temperature in degree Celsius & Fahrenheit (0C & 0F), Hart rate in bits per second (bps), Blood Oxygen level in percent (%), Skin Resistance/response in ohms (Ω) and Body postures & movements based on the xyz axis coordinates values accelerometer is in gravity (g).

Date	Value
2019-06-27T13:20:05.914+0530	35.29
2019-06-27T13:19:05.905+0530	35.40
2019-06-27T13:18:06.378+0530	35.40
2019-06-27T13:17:06.319+0530	34.96
2019-06-27T13:16:05.914+0530	35.51
2019-06-27T13:15:05.907+0530	35.62
2019-06-27T13:14:05.962+0530	35.40
2019-06-27T13:13:05.912+0530	35.40
2019-06-27T13:12:06.113+0530	35.73

Fig.9: Data bucket for Temperature

Fig 9 shows an example of Data Bucket for the Temperature sensor; data bucket is some kind of virtual storage where you can keep time series information over time. This information can be used to plot information in dashboards, or can be exported in different formats for offline processing.

8. APPLICATIONS:

Medical science: Patient monitoring undergoing physiotherapy and patient surveillance.

Sports science: For analysis of sport rehabilitation exercises.

Recognition of physical activities and their intensities

For Military and other: Human motion capture and analysis, for interactive dance performance, Human motion tracking for rehabilitation, for physical exercise.

9. CONCLUSION

A new approach for remote measurement and monitoring of the human body parameters based on a wearable wireless sensor network has been presented. The proposed design will be able to effectively measure and monitor human body parameters collectively.

The system uses wearable sensors, Wi-Fi standard wireless communication protocol for data transfer between the sensors node and coordinator. The coordinator allows transfer of data from sensor nodes to the IoT cloud environment, which will allow monitoring of all human body parameters on IoT platform effectively.

10. FUTURE SCOPE

In this Project “Monitoring of Human Body Parameters using wearable wireless sensor network”, the hardware part of system design is the sensor node which include digital & analog sensors, arduino nano board and node McU Wi-Fi modules, it is an important aspect of the design was miniaturization, so that the system was as nonintrusive as possible to the wearer. This was achieved by the use of wearable sensors module and nano boards with ultra low power operating devices which increases battery life for wearable sensor node.

With some modification, the system can be made available commercially. Future improvements will focus on the use of embedded board which include microcontroller with Wi-Fi device on a single board instead of Arduino nano and nodeMcU boards. Again addition of more wearable sensors such as ECG, EEG, EMG, pressure, airflow in this system, which may improves the performance of the system. Depending on the applications such as sports, medical, physical exercise where system going to be used a provision of selection of sensors can be made, would allow the system to be more advance and more comfortable for the wearer.

REFERENCES

- [1] Matthew N. O. Sadiku, Kelechi G. Eze, Sarhan M. Musa, “Wireless Sensor Networks for Healthcare” JSAER, Vol. 5, Issue 4, April 2018.
- [2] M. Logambal, Dr. V. Thiagarasu, “A Survey on Wireless Sensor Networks in Human Healthcare Monitoring System” IJIRCCE, Vol. 5, Issue 4, April 2017.
- [3] Mustafa Kocakulak and Ismail Butun, “An Overview of Wireless Sensor Networks Towards Internet of Things” IEEEExplore 978-1-5090-4228-9/2017.
- [4] R K Megalingam, Goutham Pocklassery, Galla Mourya, Ragavendra M Prabhu, “Measurement of Elder Health Parameters and the Gadget Designs for Continuous Monitoring” 3rd International Conference on Advancements in Electronics and Power Engineering (ICAEPE’2013) January 8-9, 2013 Kuala Lumpur (Malaysia)
- [5] Karandeep Malhi, Subhas Chandra Mukhopadhyay, “A Zigbee-Based Wearable Physiological Parameters Monitoring System” IEEE sensors journal, vol. 12, no. 3, March 2012.
- [6] Pramodkumar S, Rajendra Chincholi, “Realization of Biomedical Parameters of Human body and its monitoring using power line communication technology” Proceedings of SARC-IRAJ International Conference, 16th June 2013, Pune, India, ISBN: 978-81-927147-8-3
- [7] Zhongna Zhou, Wenqing Dai, Jay Eggert, Jarod T. Giger, “A Realtim System for In-home Activity Monitoring of Elders”, 31st Annual International Conference of the IEEE EMBS Minneapolis, Minnesota, USA, September 2-6, 2009, Digital Object Identifier: 10.1109/IEMBS.2009.5334915 .
- [8] Doukas, C. Samos Maglogiannis, “Advanced patient or elder fall detection base on movement and sound data” Proceedings of the 2nd International Conference on Pervasive Computing Technologies for Healthcare 2008, Page: 103 – 107. Digital Object Identifier: 10.1109/PCTHEALTH.2008.4571042.
- [9] Young bum Lee Yonsei Univ, “Implementation of Accelerometer Sensor Module and Fall Detection Monitoring System based on Wireless Sensor Network”, Engineering in Medicine and Biology Society, 2007. EMBS2007. 29th Annual International Conference of the IEEE, 22-26 Aug. 2007, Page: 2315 – 2318. Digital Object Identifier: 10.1109/IEMBS.2007.4352789.
- [10] A. Dasthagiraiah, N. Viswanadham & K. Venkateswarlu “Patient Monitoring By Using Wearable Wireless Sensor Networks with Zigbee Module”, International Journal of Computational Engineering Research (ijceronline.com) Vol. 3 Issue. 2.
- [11] Guo Xiong Lee; Kay Soon Low; Taher, “Unrestrained Measurement of Arm Motion Based on a Wearable Wireless Sensor Network”, IEEE Transactions on vol.59, no.5, pp.1309,1317, May 2010
- [12] K. Malhi, “Wireless sensors network based physiological parameters monitoring system,” M.S. thesis, Massey University, Palmerton, New Zealand, 2010.
- [13] Y. Hao and J. Foster, “Wireless sensor networks for health monitoring applications,” Physiological Meas., vol. 29, no. 11, pp. R27–R56, 2008.
- [14] N. Hamza, F. Touati, and L. Khriji, “Wireless biomedical system design based on ZigBee technology for autonomous healthcare,” in Proc. Int. Conf. Commun., Comput., Power (ICCCP’09), Muscat, Feb. 15–18, 2009, pp. 183–188.
- [15] F. Rahman, A. Kumar, G. Nagendra, and G. Sen Gupta, “Network approach for physiological parameter measurement,” IEEE Trans. Instrum. Meas., vol. 54, pp. 337–346, Feb. 2005.
- [16] Congcong Li , Zhiguo Chen , Guifa Teng, “ A Human Body Posture Detector Based on Three-axis Accelerometer” Revista de la Facultad de Ingeniería U.C.V., Vol. 32, N°4, pp. 268-275 2017, China
- [17] Ning Jia “Detecting Human Falls with a 3-Axis Digital Accelerometer” Analog Dialogue 43-07, July (2009)
- [18] The Internet of Things with ESP8266, [http:// esp8266.net](http://esp8266.net).
- [19] ESP8266 NodeMCU WiFi Devkit, user Manual V1.0., www.handsontec.com.

- [20] Analog Devices, “Small, Low Power, 3-Axis +/-3g Accelerometer,” ADXL335 datasheet, 2009[Revised 2010]. www.analog.com.
- [21] The Pluse Oximeter and Heart-Rate Sensor IC for Wearable Health, Maxim Integrated, September 2014. <https://datasheets.maximintegrated.com/en/ds/MAX30100.pdf> (accessed November 18, 2016).
- [22] Arduino Nano datasheet, <http://roboromania.ro/datasheet/Arduino-Nano-roboromania.pdf>
- [23] <https://www.arduino.cc>
- [24] <https://docs.thinger.io/arduino>, console
- [25] <https://www.sunrom.com/p/adxl345-acceleration-sensor-digital-interface>
- [26] [https://makerfabs.com/Others/product_id=555/MAX30100 Pulse Oximeter SpO2 and Heart-Rate Sensor Module](https://makerfabs.com/Others/product_id=555/MAX30100-Pulse-Oximeter-SpO2-and-Heart-Rate-Sensor-Module)
- [27] NTC Thermistor 10k Features, Specifications, Parameters & Data sheet <https://components101.com/ntc-thermistor-10k>

