

A REVIEW OF VOLTAGE FLICKER MITIGATION TECHNIQUES

Pankaj Prabhakar, Dr. Girraj Prasad Rathor

¹Research Scholar of Power System,²Associate Professor,
Technocrats Institute of Technology & Science Bhopal (M.P), India.

Abstract : In this survey paper discuss Voltage Flicker Into Power System. In the current generation most of the electrical power system devices are affected from electrical power flicker, due to this there are many devices are affected. In the last decade there are many research work in the area of Voltage Flicker and power system stability. In this review paper discuss on the different Voltage Flicker methods previous presented in this area. Also discuss the Frequency and amplitude control arise in Voltage Flicker into power system such as power system. In the last section also discuss the different affected area due to voltage flicker and in future the possibility of work in this area.

Index Terms - Voltage Flicker, Power System, current generation, (DSTATCOM) and frequency control techniques. etc

I. INTRODUCTION

Power quality in distribution systems has been attracting an increasing interest during recent years. Research studies include the quality of voltage supply with respect to temporary interruptions, voltage dips, harmonics, and voltage flicker. Voltage flicker occurs when large industrial loads, such as electric arc furnaces, rolling mills, and pumps operate periodically in a weak power distribution system. It causes voltage fluctuation at the Point of Common Coupling (PCC) with other loads and can annoy residential consumers by causing visible lighting flicker on incandescent or fluorescent lamps. The severity of the annoyance is generally dependent on the frequency and amplitude of the voltage variation and the short circuit rating at the PCC. It is reported that a small voltage fluctuation of less than 0.5% in the frequency range of 5-10 Hz can cause visible and uncomfortable incandescent flicker.[11] [12] [13]

In addition to the perceptible and sometimes irritating lighting flicker to humans, voltage flicker can also cause electrical equipment efficiency drop, torque and power oscillations, and interference in protection systems. Modern consumers require high quality power supply for their sensitive facilities. Voltage flicker has therefore been an important power quality concern for both power companies and customers. To quantify the degree of voltage flicker and to facilitate the solution of flicker related problems, various definitions and standards have been proposed. The IEEE Standard 519-1992, which is referenced widely, defines maximum permissible voltage flicker levels with respect to frequency as shown in Fig. 1.[14][15]

The most commonly used device for compensation of voltage flicker is the Static Var Compensator (SVC). Although this traditional solution has been successful in many applications, it has a relatively slow response time. Distribution Static Compensator (DSTATCOM), which consists of an IGBT-based voltage source inverter, uses advanced power switches to provide fast response and flexible voltage control at the connection for power quality improvement in distribution systems. The high switching frequency of modern power switches, together with multi-level inverter topologies make it viable to use Pulse Width Modulation (PWM) in high power applications. Using high frequency PWM, the inverter will create smooth current with low harmonic content.[16] [17][18]

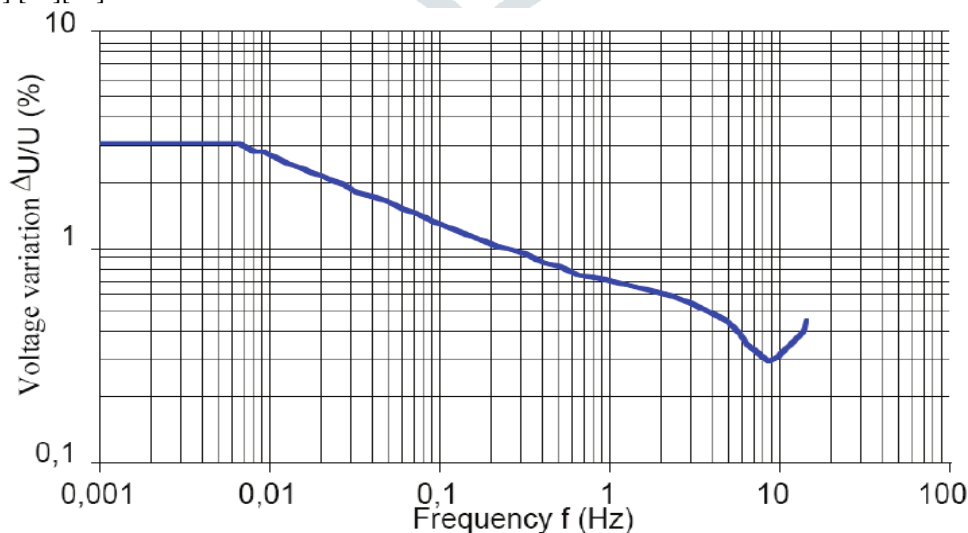

Fig. 1 Maximum Permissible Voltage Fluctuations [20]

This paper presents the digital modeling and simulation of the voltage flicker phenomenon, which was observed in a 69/13.8 kV Utility/Customer distribution system. The simulation tool is the MATLAB/Simulink Power System Blockset (PSB). The simulation shows that the degree of voltage flicker at the PCC exceeds the permissible flicker limits. To mitigate the voltage flicker problem of

this distribution system, a 15 Mvar current control PWM-based DSATCOM is added to the location of the flicker source in this PSB model. The mathematical model and the instantaneous current control strategy for this DSTATCOM are explained and discussed. The capability of the DSTATCOM to mitigate voltage flicker is demonstrated by the digital simulation.[19][20]

II. Literature Survey

Ruksana, S. K., Singh, S. K., Goswami, A. K., & Sinha, N. (2018, June)– This paper presents a detailed and enhanced review on the recent challenges for power quality impacts on wind energy system integrated with grid. The PQ issues like transients, flickers, harmonics and voltage sag or swell are clearly explained along with key highlights. The research challenges related to PQ issues with wind energy integrations will give a clear path to the researchers to work on. To mitigate the PQ impacts, researchers can use this survey for designing suitable filters and dynamic voltage restorers.[01]

Varga, T., Marić, P., Vukobratović, M., & Klaić, Z. (2018, November)–Comprehensive simulations of several wind turbine operation conditions and flicker emissions in the IEEE 37 node test feeder showed that wind generation power factor significantly affect the flicker emissions in switching and continuous mode of operation. Also, simulations that covered changes in the power factor at the beginning of the feeder i.e. the place of common coupling of the feeder with 230 kV transmission grid, has no influence on flicker emissions and occurrences. The simulation results also point how the increase of wind generation active power dispatch, such as the one from increased number of installed wind generation units, can lead to greater flicker emissions. The short and the long-term flicker emissions had the same values in continuous mode of operation, regardless of the simulation scenario, since they have been calculated with constant flicker coefficient and apparent wind turbine power, as well as the grid short-circuit power.[02]

Pal, Y., Swarup, A., & Singh, B. (2008, October). An extensive review of compensating type custom power devices has been presented to provide a clear perspective on various aspects of these devices to the researchers, engineers and manufacturers. The substantial increase in the use of solid-state power control results in harmonic pollution above the tolerable limits. According to contingency planning research company's annual study [146], downtime caused by power disturbances results in major financial losses. The presented classification of configurations and control strategies provide compensation solution to various power quality problems, viz, voltage and current harmonics, neutral current, voltage sags/swells, flicker and dip. The consumer can select a particular compensating device with the required features.[03]

Tavakkoli, A., Ehsan, M., Batahiec, S. M. T., & Marzband, M. (2008, April). In this paper , a three phase model of the electric arc furnace by depending on the Cassei/Mayr model by using the MATLAB /SIMULINK toolboxes was introduced that has the real time modeling capability of the different status of the furnace. Investigation of the results obtained by simulating is briefly as follows. 1- In order to compensate the destructive effects resulting from the furnaces specially the flicker one can use elements such as DSTATCOM and STATCOM. These elements can completely compensate the loads reactive power variations at each frequency and their response speed is very fast. 2- By using the adequate control strategy one can compensate the load non-active power, stabilize the voltage profile, reduce the voltage flicker and improve the power factor.[04]

Mohod, S. W., & Aware, M. V. (2008, September). The grid connected wind turbine system is facing the challenge for maintaining the power quality issues on the grid. This paper presents a control technique for voltage source inverter to mitigate the power quality issues. The wind generation systems are connected through the rectifier and inverter and maintain dc bus at constant voltage. The active and reactive power is made available under the steady state and dynamic condition of the main power system. The suggested control technique is suited for rapid injection or absorption of real and reactive power flow to stabilize the grid system. This is possible due to voltage source inverter control under current control mode. The result shows unity power factor at PCC, which is important point of interconnection that provides a gateway for wind generating system into a real world. The effectiveness of hysteresis controller in a tight band can provide the improvement in power quality. The MATLAB/SIMULINK simulations confirm the power quality norm on grid is maintained by this system.[05]

Molina, M. G., & Mercado, P. E. (2008, August). Dynamic system simulation studies demonstrate the effectiveness of the proposed multi-level control approaches in the synchronous-rotating dq reference frame. The improved capabilities of the integrated DSTATCOM-UCES controller to rapidly control the active power exchange between the UC bank and the utility system, simultaneously and independently of the reactive power exchange, permit to greatly enhance the operation and control of the electric system. The fast response device shows to be very effective in enhancing the distribution power quality, successfully mitigating disturbances such as voltage sags and voltage/current harmonic distortion, among others. Events such as voltage swells, flicker and power factor correction could be also lessened with the proposed device.[06]

Omar, R., & Rahim, N. A. (2008, December)-The modeling and simulation of a DVR using MATLAB/SIMULINK has been presented. A control system based on dqo technique which is a scaled error of the between source side of the DVR and its reference for sags/swell correction has been presented. The simulation shows that the DVR performance is satisfactory in mitigating voltage sags/swells. From simulation results also show that the DVR compensates the sags/swells quickly and provides excellent voltage regulation. The DVR handles both balanced and unbalanced situations without any difficulties and injects the appropriate voltage component to correct rapidly any anomaly in the supply voltage to keep the load voltage balanced and constant at the nominal value.[07]

III. Voltage Flicker with Infinite Frequencies

Domestic the voltage flicker is stochastic, that is, composed of infinite frequencies. The frequency domain analysis of a voltage flicker is important since it is shown in Fig. 2 in which the AK, value is set at 3% and the flicker components are 10 and 7 Hz. On the basis of the signal theory, an fm amplitude modulation waveform will split on both sides of the fundamental frequency in the frequency spectrum, i.e., in the positions of $(f+f_n)$ and $(f-f_n)$. Because the flicker frequencies are set at 7 Hz and 10 Hz, the separation effects appear in 50, 53,67, and 70 Hz.[8]

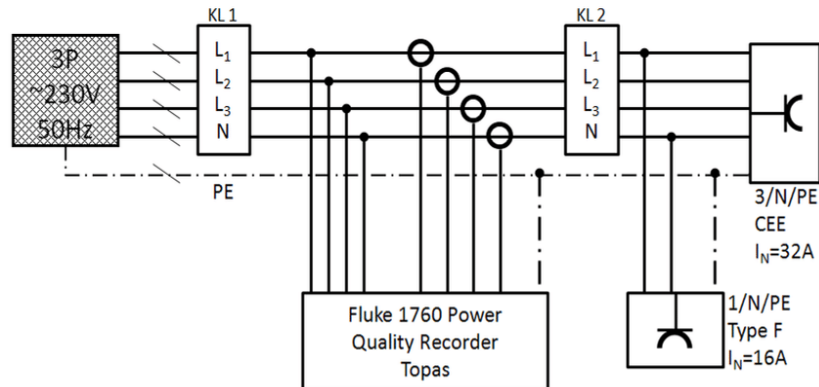

Fig 2 Voltage flicker observation and measurement setup [9]

The flicker voltages reproduced by the flicker generator can be used in the future to investigate the effect on electrical devices. The analysis procedures are listed below :

- (1) Find the envelopment of the measured voltage flicker waveform.
- (2) Use the FFT technique to calculate the frequency spectrum of the envelopment.
- (3) Find the modulation voltages A_{vn} 's, frequencies f_{njs} , [10]

(4) Re-generate this voltage flicker waveform using the flicker generator via Equ (1). and phase angles T_n 's. Steps (1) to (3) are executed in the MatLab program. On the basis of the FFT theory, a T second length signal (signal window) will generate $1/T$ Hz frequency resolution. If an N-point FFT is used for a signal with length of T seconds, a sampling interval $\Delta t = T/N$ is needed. The sampling frequency is determined by $f_{smp} = 1/\Delta t$ which should be larger than double of the maximum frequency component of For the building boundary extraction on the optical image, a two-phase process, providing first a global coarse map and then a rented boundary map, is exposed.

IV. Conclusion

In this survey paper discuss on Voltage Flicker Into Power System. The important outcomes of this paper are shown in the section of comparative analysis. In this survey paper observe that the W Voltage Flicker Into Power System is the major problem in Voltage Flicker. Also most of the design Voltage Flicker Into Power System suffer from lower gain problem. In future design a better Voltage Flicker Into Power System. That can improve all these problems in this communication area.

IV. Future Work

In future try to design Voltage Flicker Into Power System that can perform better result in terms of Power System. Flicker also create problem in image and signal transmission and generate noise in the impulse noise. [22][23][24] In future try to implement the better flicker reduction techniques and analysis in image processing. Flicker also degrade the quality of the voice single in LTE system, also try to improve the flicker problem and enhance the quality of LTE signal. [21] [25][26][27][28][29]. In future try to implement the method that is correlate with internet of things for flicker measurement and send acknowledgement of the power generation unit.[30]

REFERENCES

- [1] Ruksana, S. K., et al. "Recent Challenges for Power Quality Impacts on Grid Integrated Wind Energy System: A Review." *2018 Second International Conference on Intelligent Computing and Control Systems (ICICCS)*. IEEE, 2018.
- [2] Varga, Toni, et al. "Wind Generation Flicker Modelling and Analysis in Simulation Environment." *2018 International IEEE Conference and Workshop in Óbuda on Electrical and Power Engineering (CANDO-EPE)*. IEEE, 2018.
- [3] Pal, Yash, A. Swarup, and Bhim Singh. "A review of compensating type custom power devices for power quality improvement." *2008 Joint International Conference on Power System Technology and IEEE Power India Conference*. IEEE, 2008.
- [4] Mohod, Sharad W., and Mohan V. Aware. "Power quality issues & its mitigation technique in wind energy generation." *2008 13th International Conference on Harmonics and Quality of Power*. IEEE, 2008.
- [5] Molina, M. G., and P. E. Mercado. "Dynamic modeling and control design of DSTATCOM with ultra-capacitor energy storage for power quality improvements." *2008 IEEE/PES Transmission and Distribution Conference and Exposition: Latin America*. IEEE, 2008.
- [6] Omar, Rosli, and Nasrudin Abd Rahim. "Modeling and simulation for voltage sags/swells mitigation using dynamic voltage restorer (DVR)." *2008 Australasian Universities Power Engineering Conference*. IEEE, 2008.

- [7] Tavakkoli, A., et al. "A SIMULINK study of electric arc furnace power quality improvement by using STATCOM." *2008 IEEE International Conference on Industrial Technology*. IEEE, 2008.
- [8] Chen, Zhe. "Issues of connecting wind farms into power systems." *2005 IEEE/PES Transmission & Distribution Conference & Exposition: Asia and Pacific*. IEEE, 2005.
- [9] Sun, Tao, Zhe Chen, and Frede Blaabjerg. "Flicker mitigation of grid connected wind turbines using STATCOM." *Second International Conference on Power Electronics, Machines and Drives (PEMD 2004)*. Vol. 1. IET, 2004.
- [10] Sannino, Ambra, Jan Svensson, and Tomas Larsson. "Power-electronic solutions to power quality problems." *Electric Power Systems Research* 66.1 (2003): 71-82.
- [11] Soliman, S. A., and M. E. El-Hawary. "Measurement of power systems voltage and flicker levels for power quality analysis: a static LAV state estimation based algorithm." *International journal of electrical power & energy systems* 22.6 (2000): 447-450.
- [12] Sharaf, A. M., and Pierre Kreidi. "Power quality enhancement using a unified switched capacitor compensator." *CCECE 2003-Canadian Conference on Electrical and Computer Engineering. Toward a Caring and Humane Technology (Cat. No. 03CH37436)*. Vol. 1. IEEE, 2003.
- [13] Moreno, C. Vilar, H. Amaris Duarte, and J. Usaola Garcia. "Propagation of flicker in electric power networks due to wind energy conversions systems." *IEEE Transactions on energy conversion* 17.2 (2002): 267-272.
- [14] Driesen, Johan, et al. "The development of power quality markets." *2002 IEEE Power Engineering Society Winter Meeting. Conference Proceedings (Cat. No. 02CH37309)*. Vol. 1. IEEE, 2002.
- [15] Barker, Philip P. "Ultracapacitors for use in power quality and distributed resource applications." *IEEE Power Engineering Society Summer Meeting*. Vol. 1. IEEE, 2002.
- [16] Roberts, Bradford P. "Power quality solution alternatives for low and medium voltage continuous process loads." *2002 Rural Electric Power Conference. Papers Presented at the 46th Annual Conference (Cat. No. 02CH37360)*. IEEE, 2002.
- [17] Choma, Kent Nelson, and M. Etezadi-Amoli. "The application of a DSTATCOM to an industrial facility." *2002 IEEE Power Engineering Society Winter Meeting. Conference Proceedings (Cat. No. 02CH37309)*. Vol. 2. IEEE, 2002.
- [18] Girgis, Adly A., John W. Stephens, and Elham B. Makram. "Measurement and prediction of voltage flicker magnitude and frequency." *IEEE Transactions on Power Delivery* 10.3 (1995): 1600-1605.
- [19] Montanari, Gian Carlo, et al. "The effects of series inductors for flicker reduction in electric power systems supplying arc furnaces." *Conference Record of the 1993 IEEE Industry Applications Conference Twenty-Eighth IAS Annual Meeting*. IEEE, 1993.
- [20] López, Carlos, and Jorge Blanes. "Voltage Fluctuations Produced by the Fixed-Speed Wind Turbines during Continuous Operation-European Perspective." *Wind Farm: Impact in Power System and Alternatives to Improve the Integration* (2011): 43.
- [21] Yadav P., Sharma S., Tiwari P., Dey N., Ashour A.S., Nguyen G.N. "A Modified Hybrid Structure for Next Generation Super High Speed Communication using TDLTE and Wi-Max" accepted for publication in *Studies in Big Data, Springer Book Chapter* 2017.
- [22] Pranay Yadav, "Color Image Noise Removal by Modified Adaptive Threshold Median Filter for RVIN" in National Institution of Technology (NIT - Shilong) Conference date 28 - 29 Jan. 2015. (*Scopus*) <http://ieeexplore.ieee.org/document/7060562/>
- [23] Pranay Yadav and Parool Singh – "Color Impulse Noise Removal by Modified Unsymmetric Trimmed Median Mean Filter for FVIN" in PARK College of Engineering and Tekhnology, Coimbatore-641659, Tamilnadu, India. IEEE International Conference on Computational Intelligence and Computing. 17 - 19 Dec. 2014 (*Scopus*) <http://ieeexplore.ieee.org/document/7238369/>
- [24] Shachi Sharma and Pranay Yadav "Removal of Fixed Valued Impulse Noise by Improved Trimmed Mean Median Filter" in PARK College of Engineering and Tekhnology, Coimbatore-641659, Tamilnadu, India. International Conference on Computational Intelligence and Computing. 17-19 Dec 2014. (*Scopus*) <http://ieeexplore.ieee.org/document/7238368/>
- [25] Yadav, Pranay, et al. "Multi-Band Rectangular Zig-Zag-Shaped Microstrip Patch Antenna for Wireless Applications." *Design and Optimization of Sensors and Antennas for Wearable Devices: Emerging Research and Opportunities*. IGI Global, 2020. 66-86. [10.4018/978-1-5225-9683-7](https://doi.org/10.4018/978-1-5225-9683-7) <https://www.igi-global.com/book/design-optimization-sensors-antennas-wearable/222832> [2020].
- [26] Abhijeet Rohan, Nehul Mathur Piya Anuranjani, Pranay Yadav "A Robust Printed Dipole L- Shape Patch with Triangular Cut for Wireless Fidelity Devices", 5th International Conference on Inventive Computation Technologies (ICICT-2020) 26-28 February 2020. (Accepted), <http://icicts.com/2020/1>
- [27] Munesh Sangwan, Gopal Panda and Pranay Yadav "A MIMO Patch Antenna with P Cut for with Reduce Mutual Coupling for Wireless Range", 5th International Conference on Inventive Computation Technologies (ICICT-2020) 26-28 February 2020. (Accepted), <http://icicts.com/2020/1>
- [28] Munesh Sangwan, Gopal Panda and Pranay Yadav "A Literature Survey On Different MIMO Antenna", 5th International Conference on Inventive Computation Technologies (ICICT-2020) 26-28 February 2020. (Accepted), <http://icicts.com/2020/1>
- [29] Choudhary, Ekta, Shilpi Sharma, and Pranay Yadav. "A Modified Wideband Bow-Tie Antenna with DGS for Wireless Fidelity Range." *2018 International Conference on Advanced Computation and Telecommunication (ICACAT)*. IEEE, 2018. [10.1109/ICACAT.2018.8933583](https://doi.org/10.1109/ICACAT.2018.8933583), <https://ieeexplore.ieee.org/document/8933583>
- [30] Maurya, Sweta, Shilpi Sharma, and Pranay Yadav. "Internet of Things based Air Pollution Penetrating System using GSM and GPRS." *2018 International Conference on Advanced Computation and Telecommunication (ICACAT)*. IEEE, 2018.