

# IOT based Smart Home Automation System

<sup>1</sup>P.B.Jarande, <sup>2</sup>Usharani B. Patil, <sup>3</sup>Minal S. Gosavi, <sup>4</sup>Kajal G. Mehta

<sup>1</sup>Associate Professor, <sup>2</sup>Student, <sup>3</sup>Student, <sup>4</sup>Student

<sup>1, 2, 3, 4</sup> Department of Electronics and Telecommunication Engineering,

<sup>1, 2, 3, 4</sup>S.S.P.M's college of Engineering, kankavli, India.

**Abstract:** IOT abbreviated for Internet of Things is vastly enhancing and have become an opportunity for the wireless communication between several tools and devices in hectic daily life of humans comprised as things. This project focuses on automation of home appliances and building a smart home by using Raspberry pi as a microcontroller. This system can be planned by using several methods of wireless like Wi-Fi, Bluetooth, Zigbee module and many more. But these methods which are already used do a work of short range. To have a control on this limitation we are going to plan this project as 'IOT based Smart Home Automation System'. This highlights by allowing the user to manage the system from anywhere and any corner of the world through the Internet of Things which also provides the platform for monitoring and control of the appliances. The devices like fans and lights are controlled and automated mentioned as Smart Home Automation. By making use of Raspberry pi and Relay module this project is implemented. The injured people and very old people can be benefitted from this system by making its use.

**Index Terms** - IOT, Raspberry pi 3 module B+, Proximity sensor, MQ-3 sensor, MQ-6 sensor, Relay.

## I. INTRODUCTION

The name Home Automation describes the controlling as well as tackling of the appliances of home by using Raspberry pi which behaves as a microcontroller and by making use of internet connection. The home becomes smarter by using the concept of IOT. Now days Automation is well known because it provides protection, ease to use and ability. Home Automation can tackle all the home appliances with the help of internet. In this project, sensors sense the status of the devices and give the latest information on web page. If a person is farthest from home then by checking the status on web page he may inform someone to have a control on the devices by switching the fan and light on or off. Hence, this System has become a necessity in modern era. The IOT based Smart Home Automation systems are focusing on gaining a pleasant life with simplicity. The architecture of IOT is easy with simplicity. IOT is such a kind of platform which is improving the living standard by developing an opportunity for huge applications.

Why it is obliged to build a smart Home Automation? The answer to this query is just the useful effects of smart home. As per our need and usage we can build the system in a particular way. The wastage of electricity growth can be reduced by switching off the devices which are in their working stage. This may help us to decrease the quantity of electricity wasted each year. There is a necessity of achieving the successful result or a solution to deal with this. Home automation system provides the services to perform the regular tasks in home. The three main specifications of this system like operation, handling and monitoring is done. The user and the system have an eco-friendly influence on each other. In the modern world everyone is using internet whether it may be on mobile or computer. Internet proves to be a necessity for everyone and it provides the ease to control the home appliances like light, fan and many others.

## II. LITERATURE SURVEY

The areas of Internet of Things has been mentioned which range from clever education, agriculture, health service etc. Arduino is used here for the control on the appliances. The biggest issue on IOT is security. IOT is a time consuming technology. [1]

It presents the wireless Home Automation technology which is a system that makes use of computers or the mobile handsets to have a control on the functions of home from any corner of the world through internet of things. Because of the use of wireless technology there is no cable required. Anyone is able to use it because of the applications of mobile. [2]

IOT based home automation using Raspberry pi is implemented. Smart phone is used here which access the web page to switch off or on the home appliances. [3]

It describes the Home Automation System by using Google assistant. . The conservation of energy is done as well as it provides the increase in efficiency of the appliances. Arduino is used as a microcontroller and Google assistant is used here for sending the commands. [4]

It describes the GSM Security system design and implementation of the smart home. GSM module is available for the security system. The user is aware of the alert message service send by it. In addition, the charge of the message service may also be known to the user. [5]

It describes the Bluetooth technology used for the purpose of smart home. Arduino is used here based on ultrasonic and moisture sensors, remote control and mobile handset. Bluetooth technologies make use of mobile handset which has control on the sensors and the devices. [6]

## III. PROPOSED SYSTEM

The block diagram of the Smart Home Automation has been shown in fig. 1. This system consists of Raspberry pi 3 model B+ which is used as a microcontroller. Power supply of 3.3v is given to Raspberry pi 3B+. Several sensors are in use. Proximity sensor is used to detect the entry of the user at the door due to which the lights of the hall turns on. Google assistant is in use for switching on or off the devices like light and fan by giving various commands mentioned like OFF hall light, ON bedroom light, OFF bedroom light, ON bedroom fan and OFF bedroom fan. This is done when user migrate from hall to bedroom. The triggering is done with the help of mic. Also, the MQ3 sensor such as smoke is used to notice the detection of smoke and MQ6 sensor such

as LPG gas is used to notice the change in leakage of the gas. These notifications will be displayed on the monitor screen using IOT. It helps the people to be in safety and the get notified about this issue. By visiting the webpage address as cloud4Rpi via a login id and password user may be able to check the status of the appliances at home.

If there occurs any smoke in the home then MQ3 sensor will detect the smoke and will get notification on cloud using IOT. This notification would be helpful for everyone to understand if there is any such issue at home.

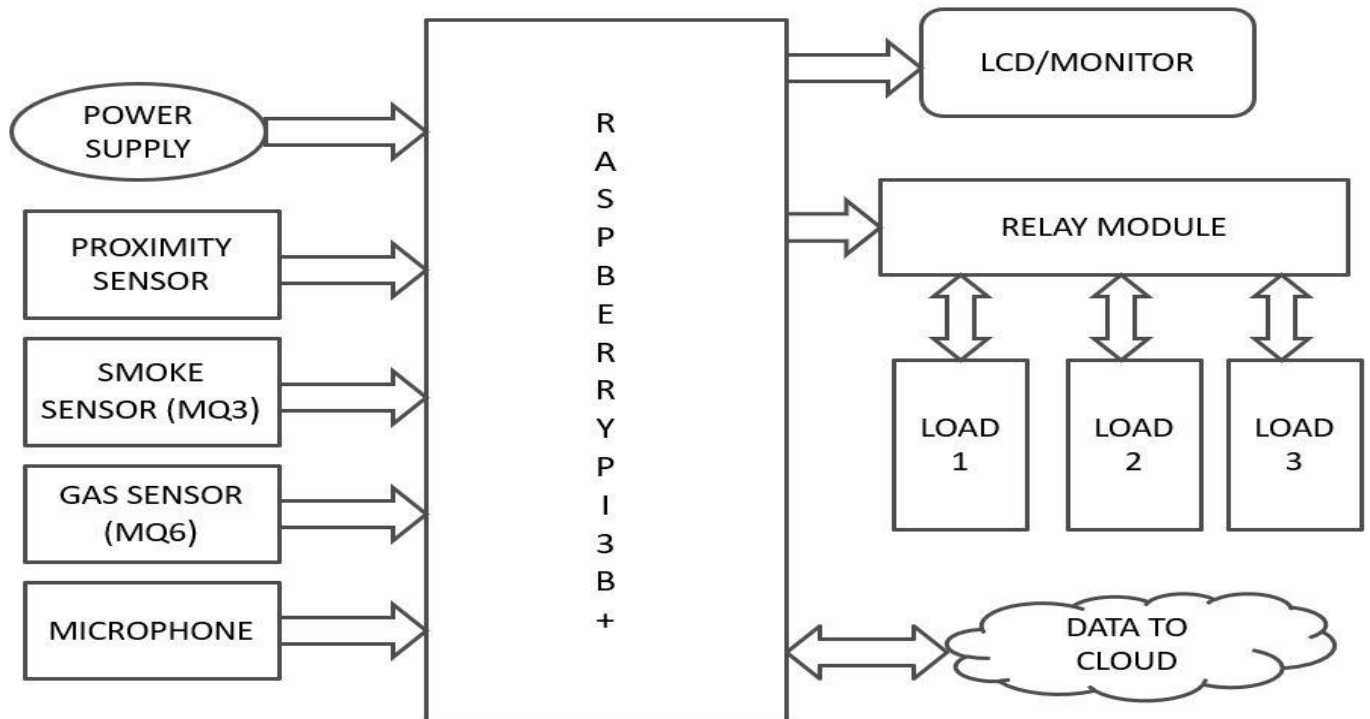

Fig. 1: Architecture of Smart Home Automation

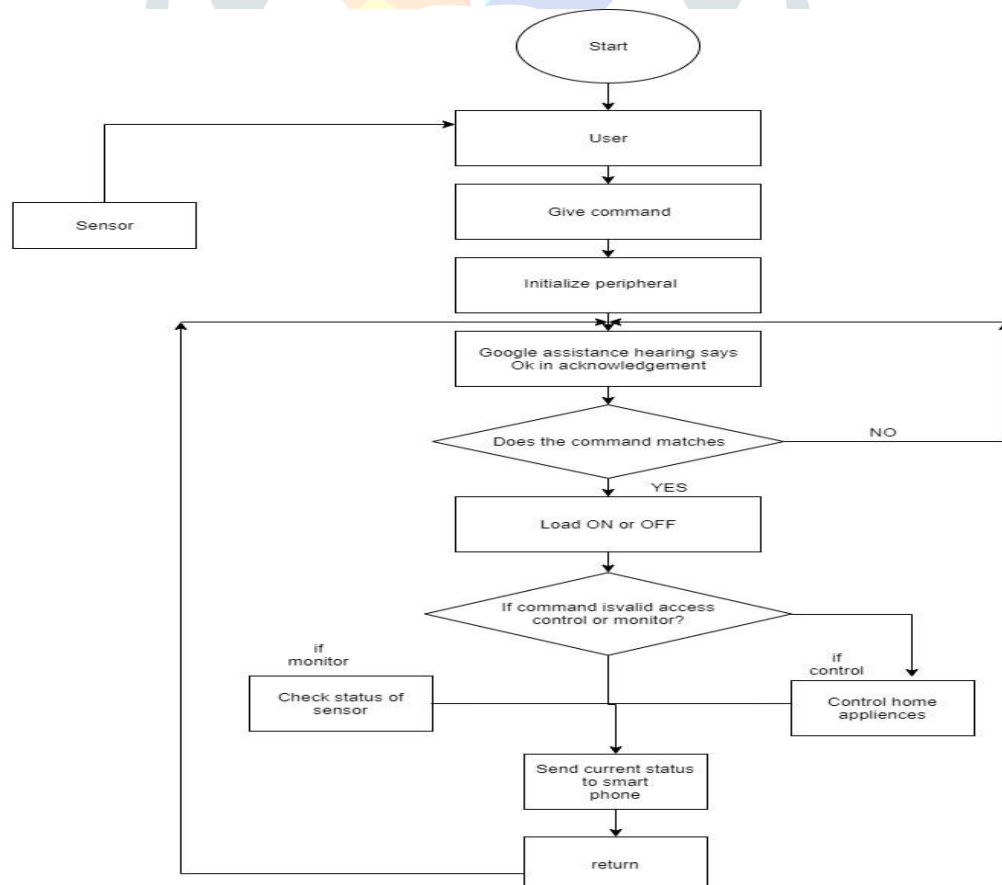

Fig. 2: Flowchart of the Smart Home System

The flowchart of the system is shown which presents the flow of the system in a systematic manner from start to end.

It consists of several hardware and software mentioned below: -

#### A. Raspberry pi 3B+

This model represents a mini computer which was known by Raspberry pi. It is the most popular advanced version used among the pi boards. The life has become easy due to evolution of technology. So instead of carrying computer Raspberry pi which is easy to carry having its own computer board is used. Raspberry pi is able to perform the functions like computers. In Raspberry pi 3B+ there are two extra USB ports which is not available in Raspberry pi 3B model. It is on chip module comprising GPU and CPU on one chip and its much faster than others in terms of speed. The two bands of Wi-Fi 802.11ac running at 5GHz as well as 2.4GHz provides a better range. There are 40 pins available which is used to provide the connection externally. 26 pins are in use as digital I/O pins out of 40 pins and out of remaining 14 pins the 9 pins are referred as dedicated I/O pins. 1GB RAM is provided in this model. Also, it consists of Micro USB power connector which is used for the transfer of the power. To enhance the capacity of memory Micro SD socket is used.

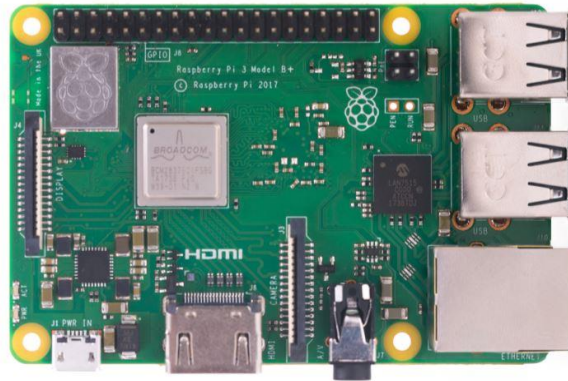

**Fig. 3: Raspberry pi 3 module B+**

#### B. USB Microphone

Universal Serial Bus microphone comprises of the USB cable which can be plug directly into the USB port. Microphone supports the function of speaking and giving the commands to further continue with its process. It requires better sound quality which should be equal to or greater than 20dB. USB microphone makes use of the technology called plug and play. Several applications are hold by this microphone such as it can perform the function of recording the music, video and can communicate with other computers users. In order to pursue the maximum audio quality, the noise interference and the external interference are cancelled.



**Fig. 3: Picture of a USB Microphone**

#### C. Relay Module

Relay has 3 input pins, 1 ground and 1VCC. It is very useful for Raspberry pi because Relay plays main role and it is considered an important component in controlling the electrically operated loads. In general, Relay is a switch where a high amount of voltage supply is present at the input. Relay is simple in complexity and it is a electromechanical component consisting of less electrical contacts and a coil. It is necessary to energize the coil so that it may not loss its mechanical nature which may release the switch and helps to have control on the load. Relays can be triggered by connecting the input pin to the ground. They are prominently in use when its important to have a control on the circuit by a low amount of power signal.



**Fig. 4: Picture of Relay**

#### D. Proximity Sensor

There are various proximity sensors and it denotes the kind of a motion sensor. With the help of the proximity sensor we can identify the presence of human entering the door. It reports the distance of the user from its nearby position. There is a high duality of life span of proximity sensor. It is light in weight and it is a portable sensor with small in size and simple design. Also, it is able to detect the presence of the object to a very short range from it. It can be made in use in front of the mobile handset such as if we touch the screen then it will be about to detect. In addition, the face recognition option in mobile handset also makes the use of this sensor as it will rectify a particular face of the owner who owns the mobile.



**Fig.5: IR sensor or proximity sensor**

#### E. Smoke sensor

MQ3 sensor consists of four pins ground, VCC, analog and digital pins. 0.04-4mg/L is the measurement range of MQ3 sensor. The working life span is high with quick response. The detection of a little bit smoke is also considered. For the analog output, the voltage at the output changes in proportional to the gas present in air. The operation is of 5V in addition with Analog combined with Digital output the threshold value is adjusted by using potentiometer.



**Fig.6: MQ3 or MQ2 sensor**

#### F. LPG Gas sensor (MQ6)

MQ6 sensor has simple functionality and it detects several gases like liquefied petroleum, isobutane, propane gas. LPG concentration in air suits the type of sensor. 200-10000ppm of gas is detected by this sensor due to its range. MQ6 sensor consists of four pins such as ground, analog and digital pins. SnO<sub>2</sub> is the conscious material of this sensor. Leakage of gas detection equipment is verified by this sensor. It comprises of on-board comparator for comparing the adjustable values and it gives output digital high or low. The interfacing of this sensor can be done with Raspberry pi.



**Fig.7: MQ6 sensor**

### G. Python IDLE

We have used python IDLE called python Integrated Development and Learning Environment of 64 bit for programming. Python IDLE can be in use for several kinds of development of software. It is simple to learn programming in this as compared to other languages which may take few days only. There are various standard libraries provided by it and said to be an object oriented language of programmers. It can be used freely since it is given by OSI and it proves to be supported by the open source license. The standard library of python helps and encourages many of the protocols of Internet like XML and HTML, processing of E-mail, IMAP and FTP are also being supported and the interfacing of socket is easier to be in use. Auto completion, syntax highlighting and smart indent are the features provided in order to create the script of python and IDLE is addition provides a text editor of completely featured.



**Fig.8: Picture of Python (64 bit)**

### H. Internet of Things

The name itself Internet of Things indicated the presence of Internet with several connected devices available. Whole around the world there are millions and billions of the physical devices which are connected to the internet for the purpose of sharing as well as collection of the information and data required. Due to this the world is becoming smarter with its intelligence. IOT has its applications in wide range starting from a home via business purpose to the industries. The world is nothing without IOT because a great source of information is gathered be it for educational purpose, medical purpose and in several other universities for presenting their work. In the implementation of the automation of smart home the use of IOT is made through which its easy to automate the home. In comparison to people more are the various things connected to the internet. IOT market has made the world advanced sue to the change in the result in upcoming years



*Fig.9: IOT*

#### IV. RESULTS

After the implantation of hardware and the programming done on the python software we are done with our project to run and a steady output as shown in fig. 10. There are the three loads connected and among them one is operated with the help of proximity sensor. Here, we achieve the protection process. For the safety of home we have used the two sensors called gas detection and smoke detection. There is no requirement of the threshold value because of digital sensors. The potentiometer value must be adjusted according to the smoke sensor that will access the amount of smoke. The commands are given to the Google assistant of Raspberry pi which will turn on or off the load according to it as shown in fig. 11. For the detection, the output will be shown 1 and the green light glow whereas the green light dims and slowly gets off for output 0. The status of home will appear on the web page by showing the detection of the smoke and gas as shown in fig. 12.



*Fig.10: Implementation of Hardware*

```

Recognizing Now ....
You have said
turn on
Hey Google
Recognizing Now ....
You have said
turn on
Hey Google
Recognizing Now ....
You have said
and on
Hey Google
Recognizing Now ....
You have said
fan on
Hey Google
Recognizing Now ....
You have said
sensor data
Published devices/7PAPzdmM0WmoJjMARMRWYBqNA/data: {'payload': {'SMOKE': 'SMOKE D
ETECTED', 'GAS': 'IDLE'}, 'ts': '2020-02-07T05:36:16.177176+00:00'}
Hey Google

```

*Fig.11: Commands displayed on screen*

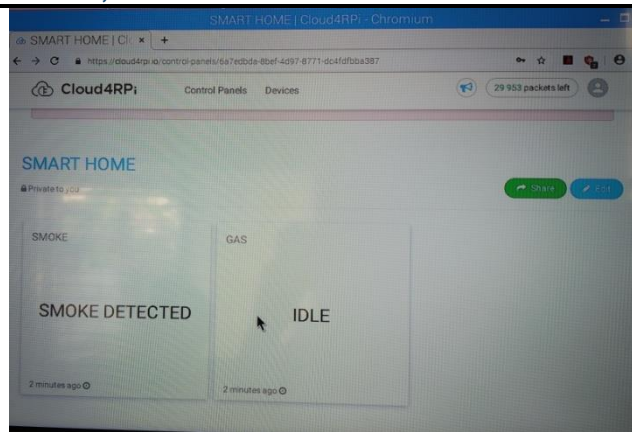

**Fig.12: Result on webpage**

## V. FUTURE SCOPE

Each one of us has been dreaming about our lifestyle in the future. It's a fantasy to imagine our life in the futuristic style. To fulfill and cater all our required needs the automation of smart home must be emerged. In addition with IOT technology we may also make use of GSM technology which will help us to get alert messages in our mobile from being anywhere in the world. The accessing of webpage will allow us to monitor and control all the loads as well as appliances. In spite of using few sensors the possibility of huge amount of sensors may be allowed which will overcome the multiple tasks. In future better automation of home with its advancement can be obtained. There will be autonomous homes as compared to the regular home which will allow the settings of the home to be adjusted as per our need based on the tasks, routines and according to our choice. The future homes may overcome the features of smart home.

## VI. CONCLUSION

This paper highlights on the solution obtained from gas and smoke safety. The main technology used here is Internet of Things with which all the devices are interconnected. Sensors are more benefitted in this project which allows us to know the status of home. The automation of home allows reducing the stress due to security, time and comfort. The implementation is completed with low cost and a unique design. Internet plays the main role here as everything is interconnected to the network.

## REFERENCES

- [1] Charlo Catalan, "home automation" [online] Available: [http://thinkingparts.blogspot.in/2015\\_08\\_01\\_arcieve.html](http://thinkingparts.blogspot.in/2015_08_01_arcieve.html).
- [2] Kumar Mandula et al., "Mobile based home automation using internet of things" in Int.conf.on control instrumentation, common and computational technologies (IccIcct), 2015, pp. 340-343.
- [3] K. Venkatesh, S. Hema Swathi, and B. Raja lingam, "IoT based home automation using raspberry pi." Jour of Adv Research in Dynamical & Control Systems, Vol. 10, 07-Special Issue, 2018
- [4] A. S. S. B. Aayush Agarwal, Anshul Sharma, "Ujala- home automation system using Google assistant," International Journal Of Pure and Applied Mathematics, vol. 119, no. 12, pp. 14083-14086, 2018.
- [5] M. Asadullah and K. Ulla, "Smart home automation system using Bluetooth technology," in 2017 International Conference on Innovations in Electrical Engineering and Computational Technologies (ICIEECT). IEEE, 2017, pp. 1-6.
- [6] E. Isa and N. Sklavos, "Smart home automation: Gsm security system design & implementation." Journal of Engineering Science & Technology Review, vol. 10, no. 3, 2017.