

# DESIGN AND ANALYSIS OF UNIVERSAL JOINT USING FEM

<sup>1</sup>Cherukuru Munikumar,<sup>2</sup>G. S. Vivek

<sup>1</sup>M.Tech Student, <sup>2</sup>Assistant Professor

<sup>1,2</sup>Mechanical Engineering Department,

<sup>1,2</sup>Chadalawada Ramanamma Engineering College, Tirupati, A.P, India.

**Abstract:** This present work deals with equivalent stresses and optimization of universal joint using three materials in order to reduce the stress concentration using FEM. Solid works CAD software was used in preparing universal joint model and CAE tool ANSYS 15.0 was used to determine Equivalent stress (Von-mises), In order to predict stress concentration regions that leading fracture and structural integrity, evaluated the universal coupling for with different material combinations. Von-mises Stress regions reflect the possibility of fracture place. Failing to design without considering these factors may lead to premature fatigue fracture and ultimately fail the entire assembly. Torque is maintained constant with 30 Nm; materials were structured steel, Grey cast iron and Stainless steel. For the optimized design, Equivalent stress (Von-mises) and deformation reduction in case of Structural steel material is better than Grey cast iron and Stainless steel.

**Index Terms - Universal joint, Grey Cast Iron, Stainless steel, Structural steel, Finite Element Method (FEM).**

## I. INTRODUCTION

Universal hook joint/coupling has been designed by Hook 350 years ago. After invention of hooks coupling so many couplings are designed and started used in different kinds of areas. Designer choice/Customer requirements create new type of couplings which can overcome the instability of rotating speeds and torque of the driven shaft. The purpose of universal joint is to provide turning moment in shafts and utilized in movable components. Universal joint consists of two yokes identified near to it and which are arranged at 90° to each other, it combined with a cross link shaft. Universal joint is used to transmit torque by rotational movement from one shaft to another, when they are placed with some angle that can be continually varied under different load conditions.

The fundamental functions of universal joints are listed below; it is extensively used in automobile Vehicle manufacturing with different mechanisms. Apart from vehicles apparatuses, air ship, control systems, electrical machines, medicinal & optical gadgets, material machinery, device drives and sewing machines.

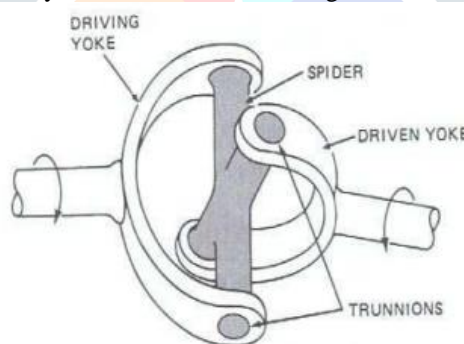

**Fig.1 Universal Coupling**

## II. LITERATURE REVIEW

The Literature audit of the past work done by different specialists in the field of structure analysis of universal joint utilizing FEM is displayed underneath. We have exhibited a survey of the important study keeping in mind the end goal to gather more data with respect to our work. Following is the literature on different works done on universal coupling.

**Abhishek Mandal et al. [1]** observed that as a result of the types of progress in PC assistant innovative investigations and planning for better couplings, it is possible to plot couplings with exceptionally improved and which can impart its failure rate. Direct static analysis on a universal coupling using Computer Aided Engineering (CAE) software and calculated various stresses and strains generated in the universal joint.

**Sunil Chaudhary et al. [2]** analyzed the stress variations of universal joint by using Finite Element Analysis (FEM). FEM analysis is performed using Computer Aided Engineering (CAE) tools. The rule focus of this postulation was to explore and research the stress variations in universal yoke inclusive genuine engine condition to transmit power and reduce weight by changing the dimensions. The tests were actualized in the Automobile named Tata 407. Apart from of all the stress, universal yoke is not damaged because of high tensile strength of the material even though it came up with short under fatigue condition. Appropriately, it is imperatively to choose the essential scope of concentrated stress for legitimate alterations. The model is laid out in CATIA software and the FEA was used with ANSYS Workbench.

**Majid Yaghoubi et al. [3]** worked on system which is can be used for the transmission of motion between two crossing shafts. A new approach is made which can comprise of one system to another with six aide arms and three associating arms, kinematic analysis is done by Autodesk Inventor Dynamic, COSMOS Motion and Visual NASTRAN. Through results for typical situations also with a steady speed it can work.

Siraj Mohammad Ali Sheik et al. [4] designed and developed a universal joint yoke and drive shaft for fracture analysis by with assistance of ANSYS for various load and torque to for a vehicle power transmission framework. Mechanical and Spectroscopic examinations are done for every part.

Purvash Shah et al. [5] investigated in re-designing of a universal coupling to transmit power between two misalign hub. Innovative designs are made to transmit movement between misalign axis. A CAD program was designed to develop a 3-D model of the universal joint for modal and stress analysis calculations.

### III. PROBLEM STATEMENT

Universal joint is one of the most crucial components in vehicles. It usually subjected bending stresses and torsional shear stresses because of driving force, weights of components. Thus, these moving components are at risk of fatigue via the nature of their operation, universal joint failure is stress concentration at some point of operation. Universal joint specially involves in angular variation operation of motor vehicle. During driving, drivers will lose control of their motor vehicle if the power shafts broke for high speed. Because of this human may be in danger if the failure prediction is not done properly, this means identifying when, where and how the universal joint will failed. It is very crucial to recognize the correct prediction for the universal joint to fail.

### IV. OBJECTIVES OF THE PRESENT WORK

In this paper universal joint is analyzed with three different materials with uniform torque conditions. Von-mises stresses are calculated along with deformation in universal joint. This analysis helps in understating the material behavior. A structural analysis of the universal joint under the loading conditions similar to practical loading conditions is helps to determine the critical region where maximum stresses and deformations occur. This analysis also helps to bring in the modifications in the design of the universal joint in order to reduce the load impact and the reduction of the weight if possible. The objectives of present work are:

1. Study the structural behavior the universal joint under the loading conditions of torsional moment.
2. Identification of the maximum torque value by failure analysis of structural steel universal joint in CAE tool ANSYS 15.0 at which it fails.
3. Identification of the sensitive part of the universal joint by performing structural analysis applying the maximum torque at which the subject is safe. The sensitive part refers to the region with maximum equivalent stress.
4. Modifications in the sensitive and non-sensitive parameters of the universal joint in order to optimize the universal joint design as an approach to obtain maximum stress and mass reduction.
5. Identification of new high torque value up to which the optimized structural steel universal joint is safe. This procedure will verify the optimization of the universal joint.

Below table is used to represent 3 different material properties used in the analysis.

Table1. Material Properties of Materials

PROPERTY	Grey Cast Iron	Structural Steel	Stainless steel
Density (kg/m <sup>3</sup> )	7200	7850	7750
Young's modulus (MPa)	1.1e+ 05	2.0e+05	1.9 e+05
Poisson's ratio	0.28	0.3	0.31
Tensile Ultimate strength(MPa)	540	460	446
Bulk modulus (MPa)	8.30e+04	1.67e+04	1.7e+05
Shear modulus (MPa)	4.30e+04	7.70e+04	7.36e+04

### V. FINITE ELEMENT ANALYSIS

Many commercial FEA software are available in market. All softwares are having their unique platform in use and no single software is supposed to have all the capabilities that can meet the complete simulation requirements of a component design. As per the designer choice or based on the requirements, some of the companies use one or more FEA software. While some companies prepare develop their own customized model software.

Some of the most popular commercially softwares are available in utilizing FEA which are as follows.

- Adina
- Abaqus
- ANSYS
- MSC Nastran etc...

Applications of FEA:

- Aircraft engineering (analysis of aero foil design, aero structures and rockets).
- Heat engineering (analysis on temperature distribution in heat exchangers, refrigeration's, heat flux etc).
- Hydraulic and hydrodynamic engineering (analysis of Bearings, boundary layer flows, viscous flow).
- Structural engineering (analysis of bridges, frames, trusses, etc).

Advantages of FEM

- Accurate dimensions
- Cost effective
- Easy modification of designs
- Optimization capacity
- No need of prototype
- No paper work
- Time Saving

About ANSYS:

ANSYS can be used for general purpose, in this context FEM packages especially for numerically models with a wide variety of mechanical and structural problems can be done by this. The problems which includes: static, dynamic, structural analysis

(both linear and non-linear), heat transfer and fluid problems. The versatile nature of ANSYS also provides the users can be able to see the effect of design problems on the complete system; this might be a electrometrical, structural, thermal etc. The procedure adopted in optimization is given in the figure 2. flow chart diagram.

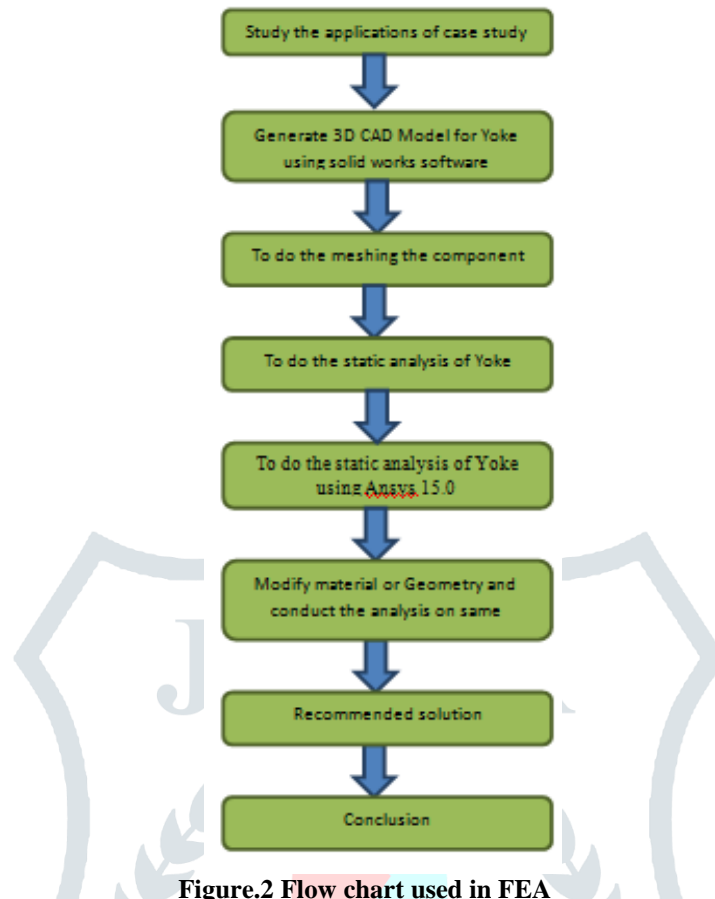

Figure.2 Flow chart used in FEA

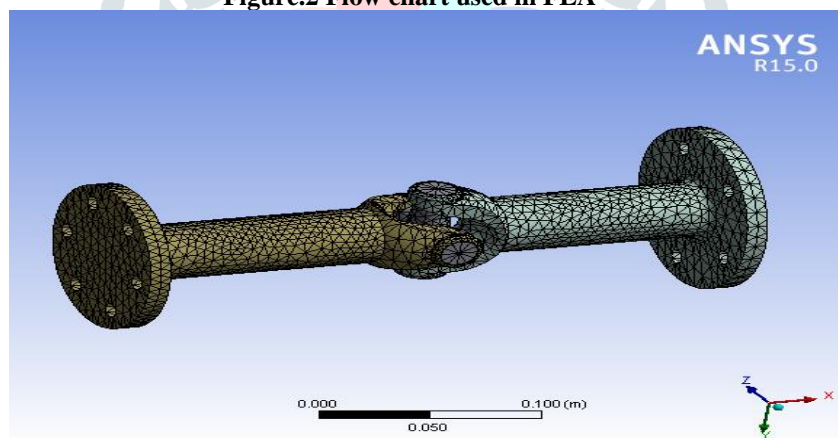

Figure 3: Mesh generated for Universal Design of Universal Coupling using structural steel

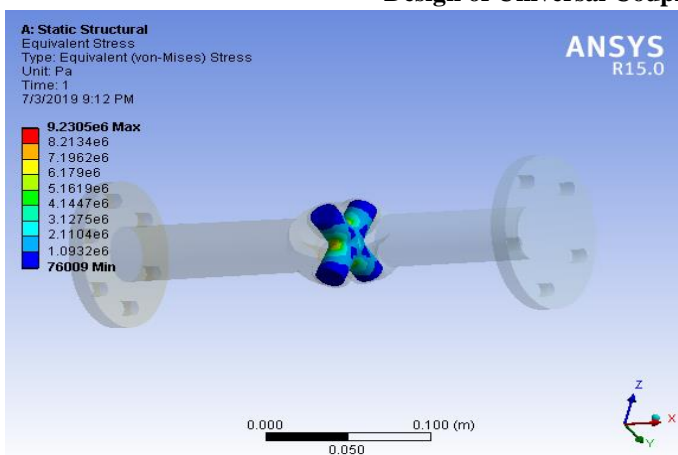

Fig.4 Equivalent Von-Mises Stresses in spider

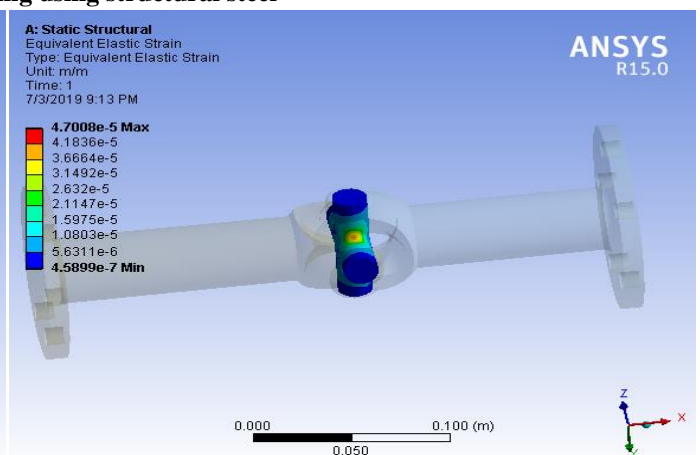

Fig.5 Equivalent Elastic Strain in spider

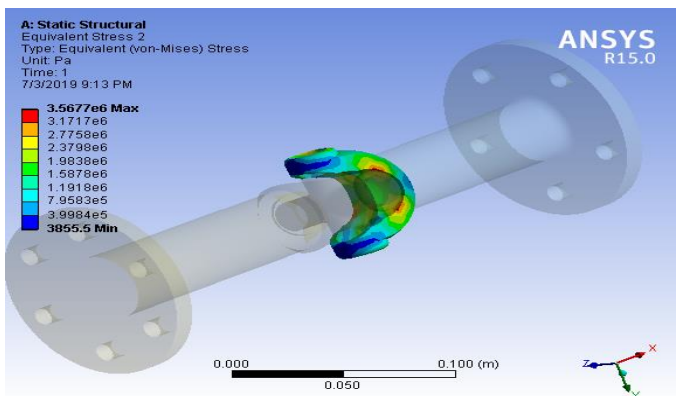

Fig.6 Equivalent Von-Mises Stresses in driven yoke

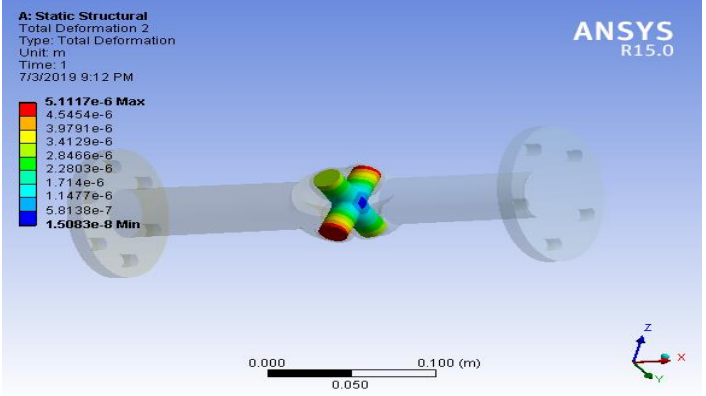

Fig.7 Deformation in spider

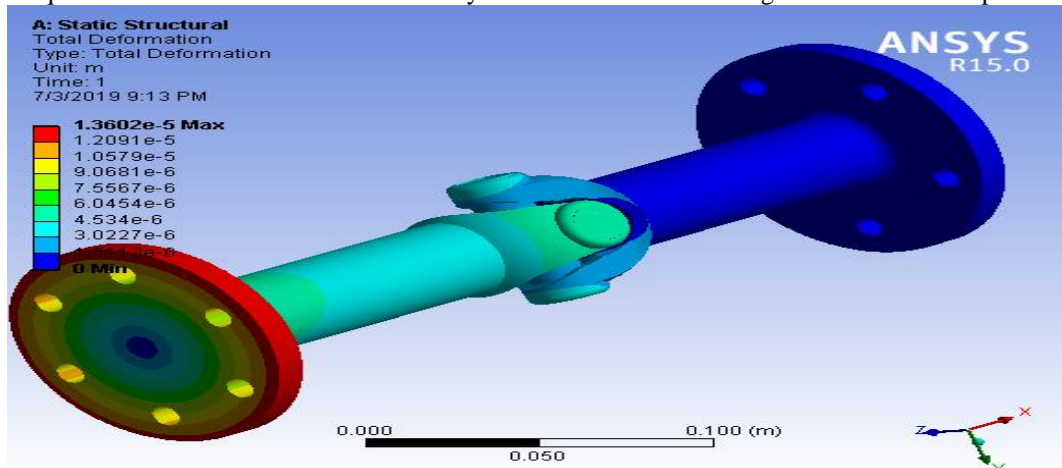

Fig.8 Total deformation in universal joint analyzed with structural steel material

### Design of Universal Coupling using Grey Cast Iron

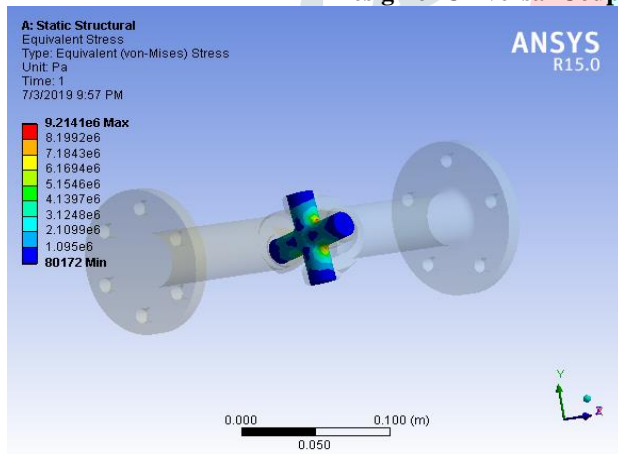

Fig.9 Equivalent Von-Mises Stresses in spider

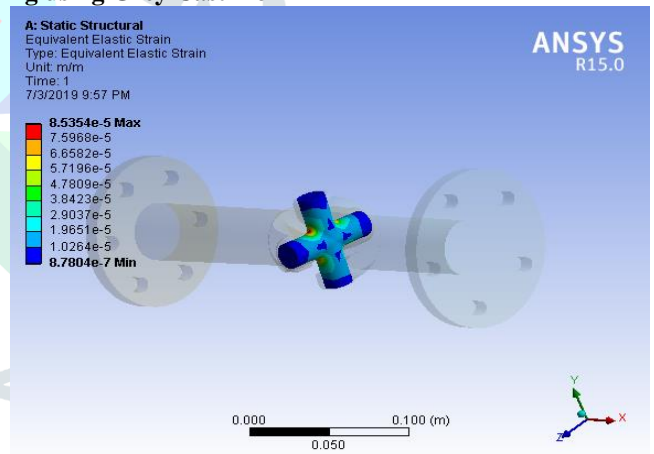

Fig.10 Equivalent Elastic Strain in spider

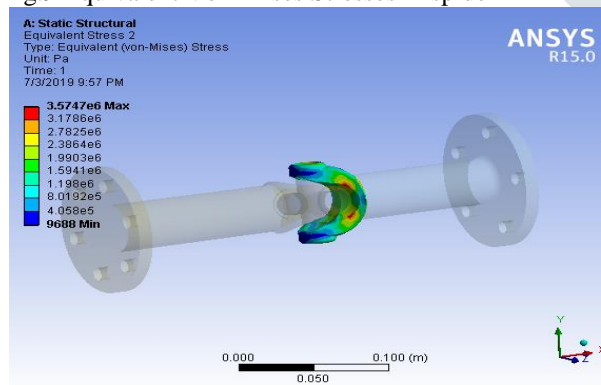

Fig.11 Equivalent Von-Mises Stresses in driven yoke

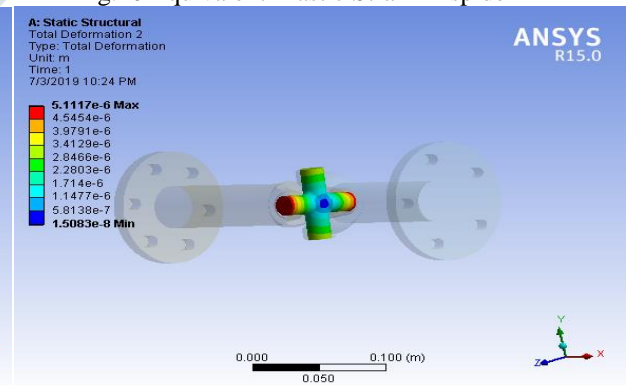

Fig.12 Deformation in spider

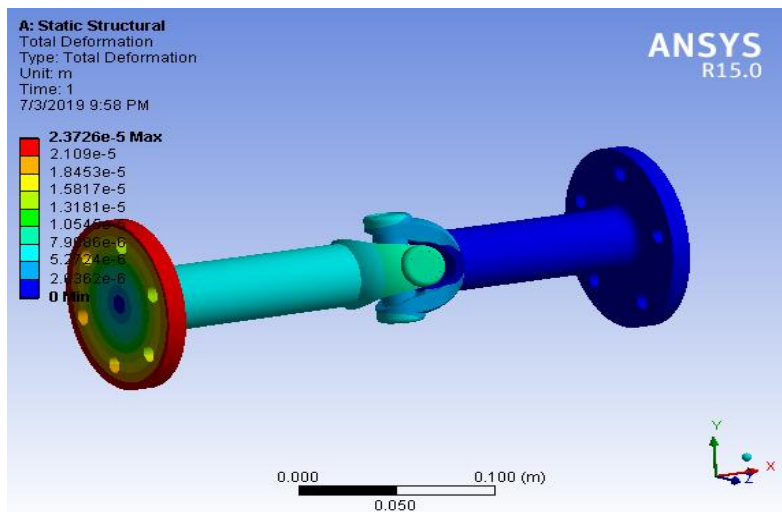

Fig.13 Total deformation in universal joint analyzed using Grey Cast Iron material

**Design of Universal Coupling using Stainless Steel**

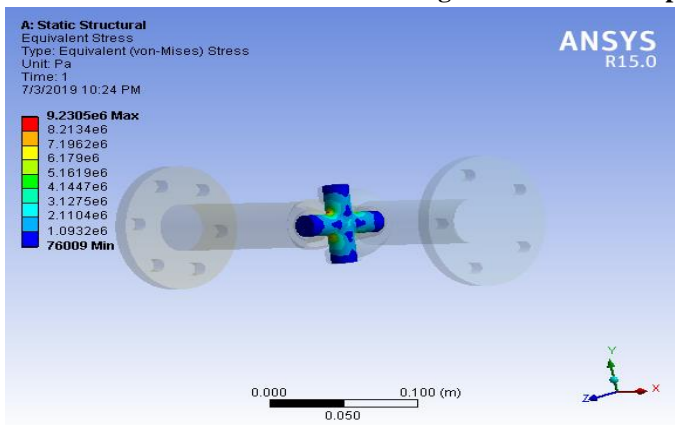

Fig.14 Equivalent Von-Mises Stresses in spider

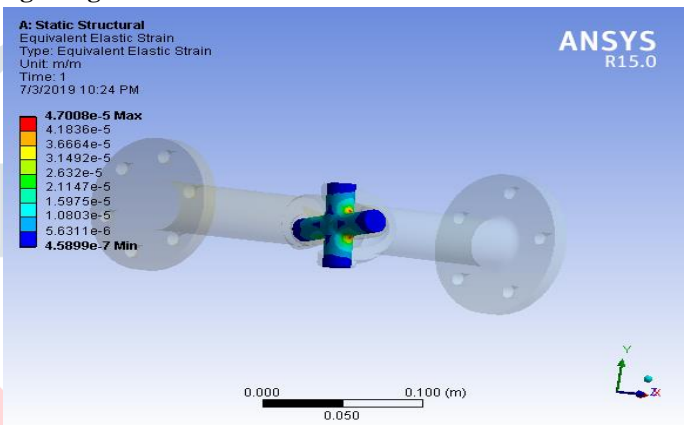

Fig.15 Equivalent Elastic Strain in driven yoke

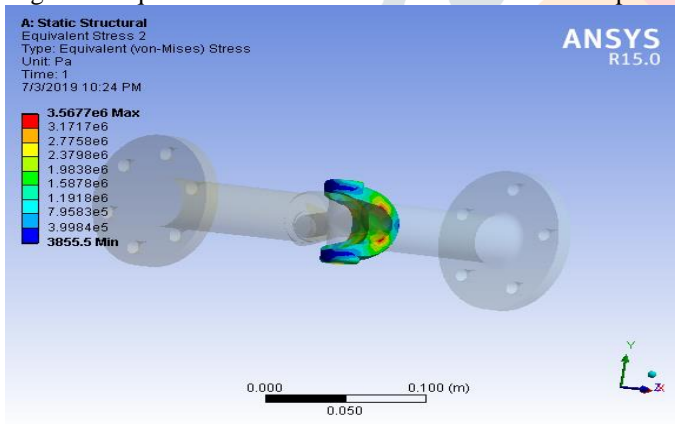

Fig.16 Equivalent Von-Mises Stresses in driven yoke

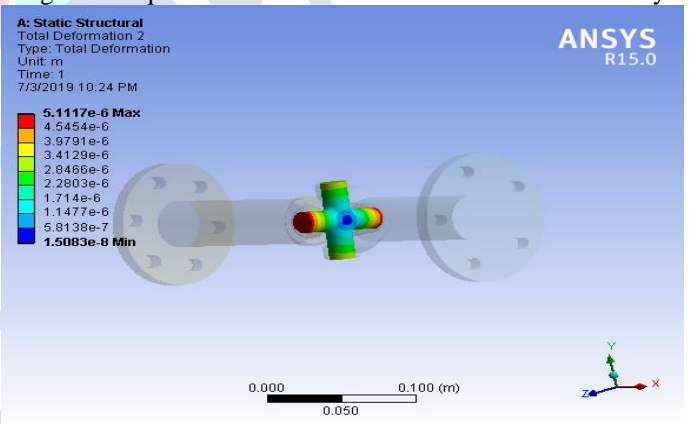

Fig.17 Deformation in spider

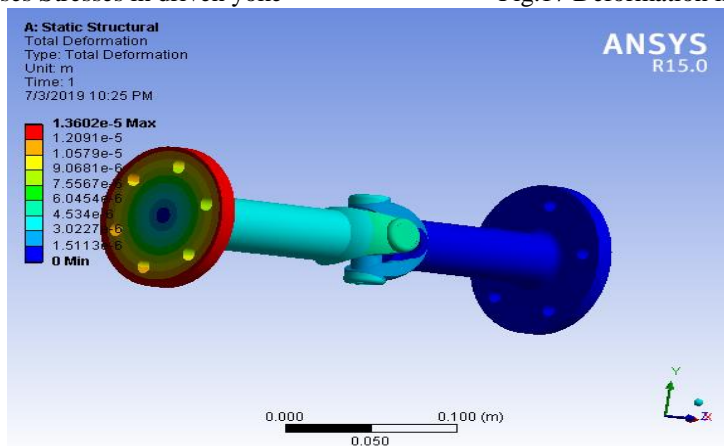

Fig.18 Total deformation in universal joint analyzed using Stainless Steel material

## VI. RESULTS & DISCUSSION

Type of Material	Equivalent Stress (Pa)		Equivalent Strain(m/m)		Total deformation(m)
	Minimum	Maximum	Minimum	Maximum	Maximum
Structural Steel	3855.5	3.5677e+06	4.5899e-07	4.7008e-05	1.3602e-05
Grey Cast Iron	9688	3.5747e+06	8.7804e-07	8.5354e-05	2.3726e-05
Stainless Steel	3855.5	3.5677e+06	4.5899e-07	4.7008e-05	1.3602e-05

1. Total Deformation is maximum value obtained in grey cast iron and for Stainless Steel and Structural Steel it is equal.
2. Equivalent Stress is almost equal in three materials but in grey cast iron it is slightly lesser.
3. Equivalent Strain is lesser in structural steel and stainless steel compared with gray cast iron.
4. Structural steel and stainless steel both got similar values in analysis but it will differ during working conditions due to carbon and other alloy percentages.

## VII. FUTURE SCOPE

Composite materials and light weight materials can be used for analysis and verified before going for production of universal hook joint, failure predictions can be found out by using analysis softwares like ANSYS and von-mises stresses induced in the expected material. Purpose of this paper is to compare the existing design with suitable material, selection in metals and improve its strength, in future alloy metals can be used for improving mechanical properties and reduction in weight.

## VIII. REFERENCES

- [1] Abhishek Mandal, Utkarsh Sharma, Harshit Pant, March-2016. Static Structural Analysis of Universal Joint to Study the Various Stresses and Strains Developed in Power Transmission Systems. International Journal of Engineering Research & Technology (IJERT), ISSN: 2278-0181, Vol. 5 Issue 03.
- [2] Sunil Chaudhry, Gopal Krishan, October- 2014. Finite Element Analysis and Weight Reduction of Universal Joint using CAE Tools. International Journal of Engineering Research & Technology (IJERT) ISSN: 2278-0181, Vol. 3 Issue 10.
- [3] Majid Yaghoubi, Ali Jafary, Seyed Saeid Mohtasebi, " Design, simulation and evaluation of a new universal joint with intersecting angle up to 100 degrees for farm machineries" published in AJAE 1(4), ISSN:1836- 9448, PP: 149-152, 2010.
- [4] Siraj Mohammad Ali Sheikh, " analysis of universal coupling under different torque condition" published in International Journal of Engineering Science & Advanced Technology Volume-2, Issue-3, pp. 690 – 694.
- [5] S. S. Mahajan, Prof. S. D. Khamankar, "Finite Element Analysis of Universal Joint" published in International Journal of Emerging Technologies and Innovative Research, ISSN: 2349-5162, Vol.1, Issue 7, page no.754-761.