

A REVIEW ON CHARGING METHODOLOGY FOR ELECTRIC VEHICLES

Ms. Anjali Gaikwad¹, Prof. Radharaman Shaha²

¹PG Student, Department of Electrical Engineering, TGPCET, Nagpur,

²Head of Department of Electrical Engineering, TGPCET, Nagpur.

Abstract- The "two" phase output is processed by using two standard single-phase PFC modules. Split diodes & inductors are used to reduce interaction between the two stages of PFC. On a universal experiment PFC prototype, the efficiency of the proposed PFC rectifier was assessed. Furthermore, a detailed analysis model is offered to calculate the power losses and efficiency of the converter for this topology. During this project, these research outcomes were developed and published in various technical papers. The cumulative interleaved DC-DC converter investigations are introduced in this research work. This optimization is done with the help of MATLAB 2018a.

Keywords- DC To DC Converter Interleaved, Power Factor Correction (PFC), Inverter.

I. INTRODUCTION

Today there is a rising requirement for the automotive industry to convert to more electrification. The rise in pollution & green transport requirements is the primary factor for increasing the international market for electric vehicles (EVs). But this increase is primarily restricted by the absence of a robust infrastructure to charge batteries or a battery charging system (BCS). A BCS is essentially made up of an electrical power interface that charges the battery of the vehicle. These BCSs must meet international standards, such as the requirements for power quality [1][2] & safety regulations[3]. The conventional component of a BCS contains a front-end diode bridge rectifier (DBR) & a DC-DC converter. To convert AC supply to unregulated DC front end, DBR is utilized. To control the battery's charge by modifying voltage & current at the end of batteries DC-DC converter stage is supplied. Yet, such BCS type takes the non-sinusoidal wind from a high-current THD generator & performs at very low PF, as seen in Figure1. Several designs have been created for power factor correction (PFC) converters to increase BCS's supply power quality. [4].

The PFC converter transforms AC supply in DC without losing energy quality on the supply side. These are DBR & DC-DC converters. That later is managed for a supply-side unit factor. The most common and easiest PFC converter is the Boost PFC converter. Yet, the PFC boost output voltage is more excellent than input voltage that can often enhance PQ operating across broad power supply in EV applications. Studies have described several bridgeless topologies also. In a bridgeless PFC converter, a DBR for improving the converter performance is removed by lowering the

conductivity of the switches. But with bridgeless PFC-converters voltage creates a high-frequency interface voltage among the line node & output ground. This produces a high-frequency noise that leads to a high ripple in the current supply. [5].

Isolation is necessary for safety reasons in any charger setup. This isolation may be supplied either on the supply side such as between the supply and the battery. There are numerous limitations to the supply side isolation since a line frequency transformer is required. For the implementation of chargers, isolated conversions are therefore often preferred[6]. In literature like Cuk, Zeta, SEPIC, Interleaved Buck converter [7], several isolated PFC buck-boost setups have been published. The Zeta PFC isolated converter is likely to have an EMI issue because of its parallel circuit amid the switch & supply system [8]. The single SEPI converter has numerous advantages among the isolated Cuk & SEPIC PFC converters [9]. This has low EMI issues, simple gate driver system design, low input current rips, & intrinsic capacity limitation when overloaded or started.

Today there is a rising desire for the automobile industry to convert to more electricity. The rise in pollution & green transport requirements is the primary factor for increasing the international market for EVs. Nevertheless, the absence of an adequate battery charge or BCS limits its progress. A BCS is essentially made up of an electrical power interface that charges the battery of the vehicle. These BCSs should meet international standards, such as the norms for power quality[1][2] and safety regulations[3]. The conventional component of a BCS contains a front-end DBR & DC-DC converter. For converting the AC supply to unregulated DC, the front end DBR is utilized, & To control the charge of the battery by adjusting voltage & current at the end of batteries, the DC-DC converter stage is supplied. Yet, such BCS take the non-sinusoidal wind from high-current THD source & function at very low PF as illustrated in Figure1. Various topologies for the PFC adjustment were designed to improve supply power quality for BCS [4]. AC supply is transformed into DC via a PFC converter without affecting the supply side power quality. These converters are made up of DBR & DC-DC. The latter is managed at the supply side to obtain a unit power factor. The most common and easiest PFC converter is the boost PFC converter. Yet, the PFC boost converter's exiting voltage is more significant than input

voltage that usually cannot be used in EV applications for a better PQ functioning across broad supply voltage. Studies have also explored other bridgeless topologies. A DBR for higher efficiency of the converter, via the reduction of conductive losses, is removed with an inverter PFC converter. Yet, the power between the line node and the output ground in bridge-less PFC converters produces high-frequency switch node voltage.

This brings in high noise in standard mode, leading to a high rip of the supply current [5]. Isolation is necessary for safety purposes in any charger configuration. This isolation may be supplied either on the supply side or among supply & battery. There are numerous limitations to the supply side isolation since a line frequency transformer is required. For the implementation of a loader, an isolated converter is therefore often preferred[6]. Many different PFC buck boost designs have been described in works like Cuk, Zeta, SEPIC [7] converters. The Zeta PFC isolated converter is more likely to have an EMI issue because of its sequence association between switch & supply devices [8]. The isolated SEPIC converter has several advantages between isolated Cuk & SEPIC PFC converters [9]. It has a minor EMI issue, a simple design of gate control circuits, low input currents, and intrinsic limitation of current capacity at overload or starting. In addition, during DCM operation, the input current might be constant.

In this study, an isolated single-stage charger is employed to charge EVs effectively. The input PF on the grid side is retained at a unit with minimal THD in grid current. The SEPIC PFC isolated converter is suggested for operating with DCM mode. DCM minimizes the size, cost & EMI problems of the magnetic components. The charger provided is meant to take into account various voltage changes in the supply system.

In addition, during DCM operation, the input current may be continuous. In this study, an isolated single-stage charger is employed for the efficient loading of EVs. Grid side Input PF is kept unitary, and the grid current is minimally THD. The converter is intended for the functioning of the DCM model. DCM minimizes the size, cost & EMI problems of the energy harvesters. Due to a large number of voltage variations in the supply system, the utilized charger is built. Depending on the following usual assumptions, the wave current of the capacitor is analyzed [4], [5].

- 1) Voltage input is sinusoidal & even the unit's PF, independent of the control system, is appropriately regulated.
- 2) The frequency of switching is much greater than the frequency of the line.
- 3) The performance of power conversion is 100%.
- 4) Vbus's bus voltage is stable.
- 5) The input voltage is considered proportional to converted line voltage in the middle of the switching cycle throughout each switching period.

In contrast, as in [4], the switching cycles are computed individually, i.e., a quasi-static method is employed, which might lead to current steps in CCM. Nevertheless, this is not likely to cause a significant problem because of the large ratio between switching frequency & line frequency. The voltage in n th switching cycle $v_{in}(nT_s)$ depending on these conditions [4].

$$v_{in}(nT_s) = V_{in} \left| \sin \left(\omega \left(nT_s + \frac{T_s}{2} \right) \right) \right|$$

When T_s is the PFC stage switching time, $\omega = 2\pi f_{ac}$, & f_{ac} is the frequencies of the ac line. PFC P_{bus} output is expected to be constant & equivalent for average input P_{in} , which is to say

$$P_{bus} = \frac{V_{in} I_{in}}{2} = P_{in}$$

Where the input current amplitude is I_{in} .

Currently, most PHEVs are passenger automobiles. But PHEVs are also accessible as vans, trucks, buses, motorbikes, scooters & military vehicles. They are also available for commercial usage. The standard charger used in PHEV incorporates a Power Factor Corrector (PFC) with AC-DC converter accompanied by an isolated EMI input and output DC conversion device. Ac-dc is a critical element of the charging system in the front-end converter. Appropriate selection of this topology is essential to fulfilling regulatory criteria for harmonics with input current, voltage control & PFC.

The classic charging infrastructure situations contain overnight charges at a house garage, charges for the night at a building, and charges for businesses. Instead of compensating poor infrastructure with more battery capacity and scope, the total cost of transport systems may be decreased by offering a rich charging facility.

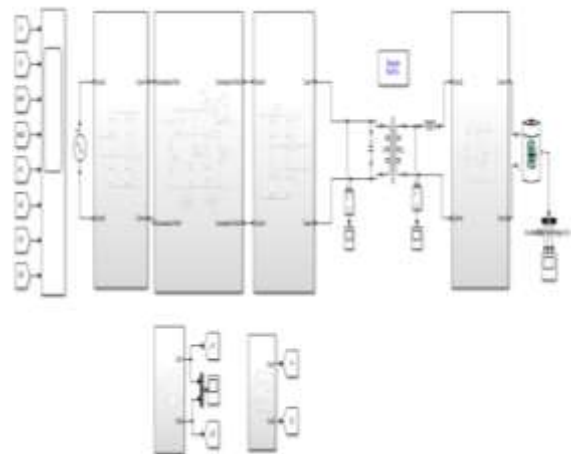

Figure .1. Simulation of Converter Circuit

II. SYSTEM DESIGN

2.3. Single Phase Inverter

2.1. Interleaved Buck Converter

A step-down converter is a DC-to-DC energy converter that goes from a higher voltage (with rising current) at its input (supply) to a lower voltage (with less current) at its output (load). SMPS is a type of switching mode power supply, and a two-semiconductor SMPS requires at least a diode and a transistor; Buck converters have increasingly used newer techniques, such as diodes or two transistors in place of a diode and a synchronous rectifier with one energy storage component (capacitor, inductor, or both). Capacitors are generally used to decrease voltage ripple, and that is achieved by using inductors (usually in conjunction with capacitors) to the inputs and outputs of a converter.

A full-bridge converter is also a primary circuit used to convert dc to ac. A circuit generated from a dc input uses switches to be closed and opened in a specific order to get an ac output. Based on which switches are locked, there are four possible states. It is not secure to connect the S1 and S4 switches at the same time. In parallel, S2 and S3 should also be closed. A short circuit would be formed in the dc power supply otherwise. Switches that are real don't instantly turn on or off.

For this reason, control of switches requires an allowance for switching transition periods. Overlap two overlapping switches set to "on" will generate a short circuit between the dc voltage source and produce a shoot-through fault. During the blanking period, it is OK to switch channels.

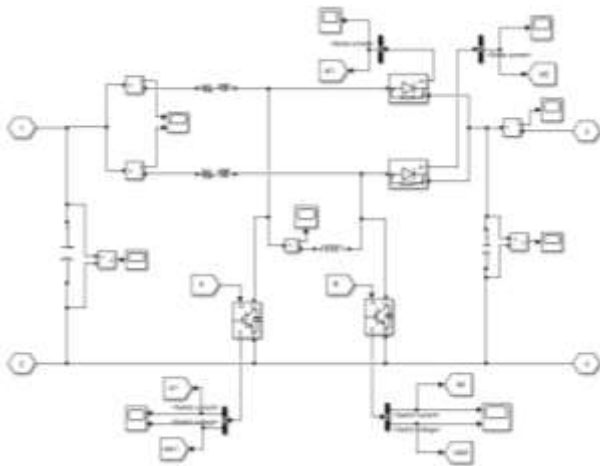

Figure.2. Simulation of Interleaved converter

2.2. Uncontrolled Rectifier

The peak A.C supply of 325V is given to an uncontrolled rectifier or full-bridge rectifier it consists typically of 4 Diodes and a capacitor to smoothen the ripple contents. The diodes D1 and D3 operates in a positive half cycle and the Diodes D2 and D4 operate in a negative half cycle. Thus it acts Like a full bridge rectifier.

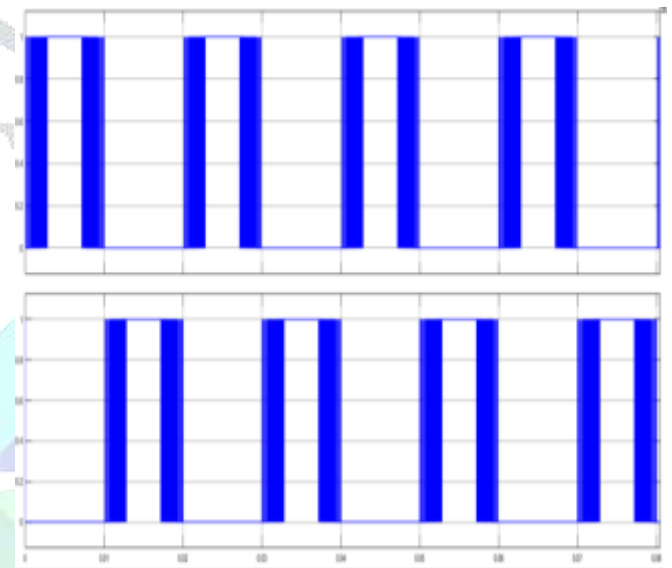

Figure.4. Gate firing pulses of Single Phase Inverter

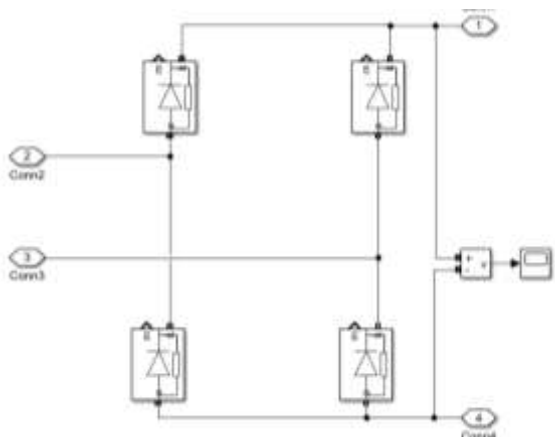

Figure.3. Uncontrolled rectifier

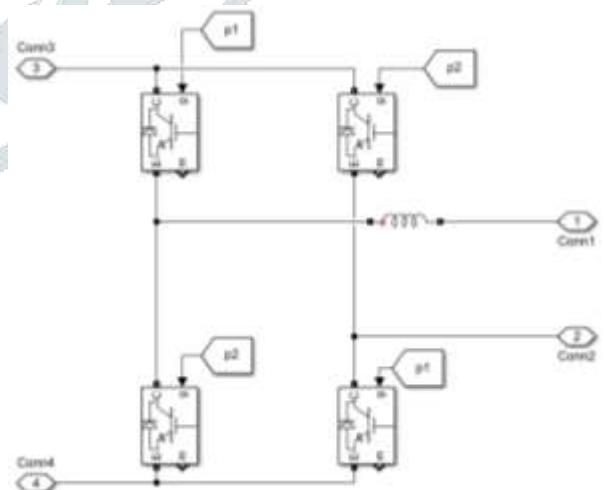

Figure.5. Simulation of Single Phase Inverter

III. SIMULATION RESULTS

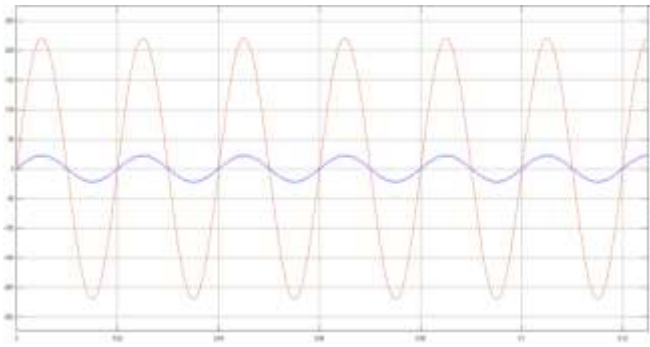

Figure 6. Output Result of Voltage and current

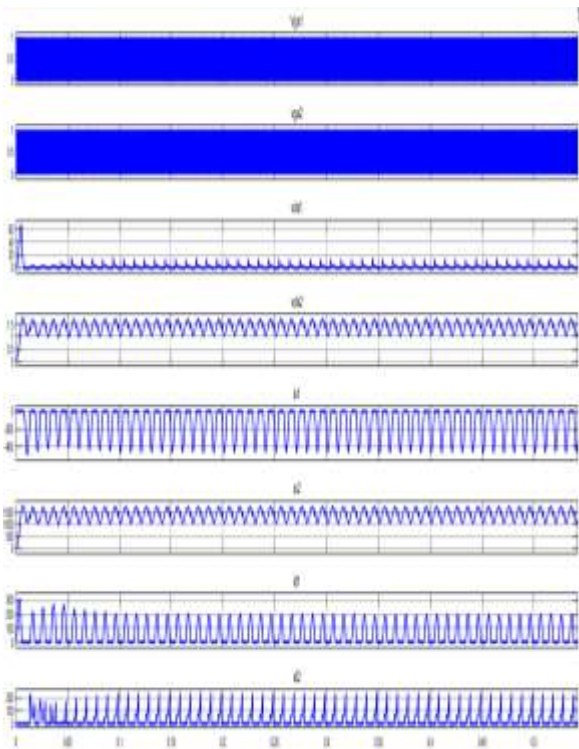

Figure 6. Output Result of internal current of power Switches

IV. CONCLUSION

It may be concluded after the study that the suggested AC-DC converter performed well in simulation when connected to the power grid and used to charge batteries in electric/hybrid vehicles. Therefore, based on the results seen, this conclusion can be deduced because the converter has proven to be an effective imposition of sinusoidal current at the input, having demonstrated decent reaction in control of injected current, along with having shown effective implementation of imposition of sinusoidal current at the input, which allows inferring that it possesses capacity factor of meeting two fundamental requests in practical battery charger implementations. Furthermore, the above information may be proven since input current may be retained by minimal harmonic content and THD is less than 6% PF near to 0.99 & output voltage, a ripple less than 2%.

It has also been discovered that a bridgeless topology may be successfully deployed, even if this included using an

input current that was insensitive to the converter's efficiency & dynamism. These two essential elements of the work will lead to increased performance in practice and make it possible to deal with more powerful entities in a more straightforward and condensed framework; it also probably enhances the rise in the converter's capacity to do work.

REFERENCES

- [1] J. Zhu and A. Pratt, "Capacitor ripple current in an Interleaved PFC converter," in Proc. IEEE Power Electron. Spec. Conf., 2008, pp. 3444–3450.
- [2] M. Borage, S. Tiwari, S. Bhardwaj, and S. Kotaiah, "A full-bridge DC-DC converter with zero-voltage switching over the entire conversion range," IEEE Trans. Power Electron., vol. 23, no. 4, pp. 1743–1750, Jul. 2008.
- [3] A. J. Mason, D. J. Tschirhart, and P. K. Jain, "New ZVS phase shiftmodulated full-bridge converter topologies with adaptive energy storage for SOFC application," IEEE Trans. Power Electron., vol. 23, no. 1, pp. 332–342, Jan. 2008.
- [4] M. M. Yungtaek and J. Jovanovic, "Interleaved boost converter with intrinsic voltage-doubler characteristic for universal-line PFC front end," IEEE Trans. Power Electron., vol. 22, no. 4, pp. 1394–1401, Jul. 2007.
- [5] Y. Jang and M. M. Jovanovic, "A new PWM ZVS fullbridge converter," IEEE Trans. Power Electron, vol. 22, no. 3, pp. 987–994, May 2007.
- [6] M. M. Yungtaek and J. Jovanovic, "Interleaved PFC boost converter with intrinsic voltage-doubler," IEEE Trans. Power Electron., vol. 19, no. 3., Jul. 2007.
- [7] A.K.S.Bhat and F. Luo, "A Novel Pulse Width Control Scheme for Fixed-Frequency Zero-Voltage-Switching DC-to-DC PWM Bridge Converter(A.K.S ,," in Proc.IEEE Int. Conf. PEDS, 2003, vol.1, pp. 8–15.
- [8] Y. Jang and M. M. Jovanovic, "A new family of fullbridge ZVS converters," IEEE Trans. Power Electron., vol. 19, no. 3, pp. 701–708, May 2004.
- [8] B. S. Singh, B. N. Singh, A. Chandra, K. Al-Haddad, A. Pandey, and D. P. Kothari, "A review of single-phase improved power quality AC-DC converters," IEEE Trans.Ind. Electron, vol. 50, no. 5, pp. 962–981, Oct. 2003.
- [9] G.-B. Koo, G.-W. Moon, and M.-J. Youn, "Analysis and design of phase shift full bridge converter with series-connected two transformers," IEEE Trans. Power Electron., vol. 19, no.2, pp. 411–419, Mar. 2004.
- [10] Junming Zhang, "A Novel Zero-Current-Transition Full Bridge DC/DC Converter," IEEE Trans. Power Electron., vol 22,no 2,pp 746-754.
- [11] Junming Zhang, " Analysis and Optimal Design Considerations for an Improved Full Bridge ZVS DC-

- DC Converter with High Efficiency IEEE Trans. Power Electron, vol.21, no. 5, pp. 1225– 1234, Sep. 2006.
- [12] Syed Q. Ali, "Integrated Battery Charger for Delta Connected Machines in Plug-in Hybrid Electric Vehicles," IEEE Trans. Power Electron, vol. 13, no. 1, pp. 332–342,
- [13] Maxx Patterson, "Hybrid Microgrid Model Based on Solar Photovoltaic Battery Fuel Cell System for Intermittent Load Applications," IEEE Trans. Power Electron, vol. 22, no. 2, pp. 987–994, May 2002.
- [14] SerkanDusmez, "A Compact and Integrated Multifunctional Power Electronic Interface for Plug-in Electric Vehicles," IEEE Trans. Power Electron., vol 17,no 1,pp 448-458 sep 2004.
- [15] P.-W. Lee, Y.-S. Lee, D. K.W. Cheng, and X.-C. Liu, "Steady-state analysis of an interleaved boost converter with coupled inductors," IEEE Trans. Ind. Electron., vol. 47, no. 4, pp. 787–795, Aug. 2000.
- [16] B. A. Miwa, D. M. Otten, and M. E. Schlecht, "High efficiency power factor correction using interleaving techniques," in Proc. IEEE APEC1992, Feb., pp. 557–568.
- [17] J. R. Pinheiro, H. A. Grundling, D. L. R. Vidor, and J. E. Baggio, "Control strategy of an interleaved boost power factor correction converter," in Proc. 30th Annu. IEEE Power Electron. Spec. Conf., Jun. 1999, pp. 137–142.
- [18] D. Kubrich, M. Schmid, and T. Durbaum, "A fast calculation tool for the design of PFC converters-method and application," in Proc. 31st Annu. Conf. IEEE Ind. Electron. Soc., Nov. 2005, pp. 900–905.
- [19] T. Kurachi, M. Shoyama, and T. Ninomiya, "Analysis of ripple current of an electrolytic capacitor in power factor controller," in Proc. 1995 Int. Conf. Power Electron. Drive Syst., Feb., pp. 48–53.
- [20] M. A. P. Andrade, L. Schuch, and J. R. Pinheiro, "Generalized switching logic scheme for CCM-PFC interleaved boost converters," in Proc. 35th Annu. IEEE Power Electron. Spec. Conf., Jun. 2004, pp. 2353–2359.
- [21] C. H Chan and M. H. Pong, "Input current analysis of interleaved boost converters operating in discontinuous-inductor-current mode," in Proc. 28th Annu. IEEE Power Electron. Spec. Conf., Jun. 1997, pp. 392–398.
- [22] V. A. Sankaran, F. L. Rees, and C. S. Avant, "Electrolytic capacitor life testing and prediction," in Proc. IEEE Ind. Appl. Soc. Annu. Meet., Oct. 1997, pp. 1058–1065.
- [23] D. Xu, J. Zhang, W. Chen, J. Lin, and F. C. Lee, "Evaluation of output filter capacitor current ripples in single phase PFC converters," in Proc. Power Convers. Conf., Apr. 2002, pp. 1226–1231.
- [24] L. Balogh and R. Redl, "Power-factor correction with interleaved boost converters in continuous-inductor-current mode," in Proc. IEEE APEC 1993, Mar., pp. 168–174.
- [25] UCC2817, UCC2818, UCC3817, UCC3818 BiCMOS Power Factor Preregulator, SLUS3951, Data Sheet, Texas Instruments Incorporated, Dallas TX, Feb. 2000, Revised Feb. 2006.
- [26] J. Sun, "New leading/trailing edge modulation strategies for two-stage PFC ac/dc adapters to reduce dc-link capacitor ripple current," M.S. thesis, Dept. Electr. Eng., Texas A&M, College Station, 2007.
- [27] G. Koo, G. Moon, and M. Youn, "Analysis and design of phase shift full bridge converter with series-connected two transformers," IEEE Trans. Power Electron., vol. 19, pp. 411–419, Mar. 2004.
- [28] J. A. Sabate, V. Vlatkovic, R. B. Ridley, F. C. Lee, and B. H. Cho, "De-sign considerations for high-voltage high-power full-bridge zero-voltageswitched PWM converter," in Proc. IEEE APEC 1990, Mar., pp. 275–284.