



POWER ELECTRONIC CONVERTERS RELIABILITY MODELING

¹Reshma Sulthana S S, ²Shabana S S

^{1,2} Lecturer

Department of Electrical and Electronics Engineering

Government Polytechnic, Bellary, Ballari, India

Abstract: Reliability modeling of power electronic converters is of paramount importance for optimal design, control and operation of power electronic based power systems. Suitable topology selection, converter components sizing, and proper control strategy adoption in a single unit converter together with operation of a multi-converter systems require to predict the converter reliability within its useful life and wear-out phases. This paper proposes a reliability prediction approach for converters modeling the hardware random failures within the useful life and the wear out period. The methodology is exemplified for a single-phase PV inverter and its reliability is predicted during useful lifetime and the wear-out phase under two operating conditions.

Index Terms - reliability, converter reliability, constant failure rate, wear-out failure, systematic failure, catastrophic failure.

I. INTRODUCTION

Power electronic converters are increasingly used in a wide range of applications such as distributed generations, especially in renewable energies, ultra/- high voltage transmission systems, medium voltage distribution systems, e-mobility, and microgrids. Thus, they are becoming the underpinning technology in the modernization of future power systems [1]. Therefore, optimal and economical design, control, operation and maintenance of power converters and power electronic based power systems have intensified the importance of reliability modeling and prediction in power converters [2], [3]. According to IEEE Std 1413, the use of reliability prediction includes reliability goal assessment, comparisons of designs and products, identifying potential reliability enhancement opportunities, logistics support, reliability and system safety analysis, mission reliability estimation, and prediction of field reliability performance [4]. Therefore, for design, planning, operation and maintenance of a system, reliability assessment is of paramount importance even if no or limited reliability data are available [5]. In power electronic converters, reliability assessment is required for optimal and reliable design, comparison among different topologies and alternatives, and identifying reliability improvement techniques such as suitable modulation algorithms or control systems, maintenance scheduling, and so on. So far, different approaches have been employed for reliability prediction in power converters. The mostly common used approach is based on Military Handbook 217 (MIL-HDBK-217). This approach cannot accurately model the reliability of some components such as semiconductor devices, since the provided model does not take into account the mission profiles and physics of failures. Especially, for semiconductors, the temperature cycling, which is a dominant failure cause, has not been included in MIL-HDBK-217F methodology. Therefore, the International Electrotechnical Commission (IEC) provided a Technical Report (TR 62380) in 2004 [6], which considers the temperature cycling in failure rate prediction throughout an annual mission profile. Both reports provide a base failure rate for different components and correction factors considering the operating conditions. However, they have not updated the data source for new devices with new technologies. Therefore, the IEC TR 62380 has been replaced by IEC 61709 in 2017 [7], which provides a guideline in order to use the failure rate data for predicting the reliability of components considering the mission profiles. In the aforementioned handbook methods, the physics of failures has not been considered. Therefore, the predicted reliability may not be accurate enough. Moreover, identifying the weak points for reliability enhancement is not clear. Thereby, the FIDES approach has been introduced in which the physics of failures of components are considered for failure rate estimation [8]. This approach provides more accurate failure rate of components compared to the previous methods. All the handbooks provide a constant failure rate for components during their useful lifetime. It is assumed that the components are appropriately designed and they do not enter the wear-out phase during the mission life period [6], [8]. Therefore, the predicted reliability may be suitable for availability analysis during operation, while for design, planning (e.g., topology selection, redundant design, design for reliability) and maintenance, end-of-life estimation is necessary. The end-of-life estimation requires modeling the wear-out failures as well. This fact becomes more important since some components are exposed to wear-out failures, which can affect the overall performance of the converter and system. This paper proposes a general reliability prediction approach for power converters according to the failure causes on the most failure prone components.

II. FAILURE CAUSES AND MECHANISMS IN CONVERTERS

The general failure causes can be classified into random and systematic failures as shown in Fig. 1 [9], [10].

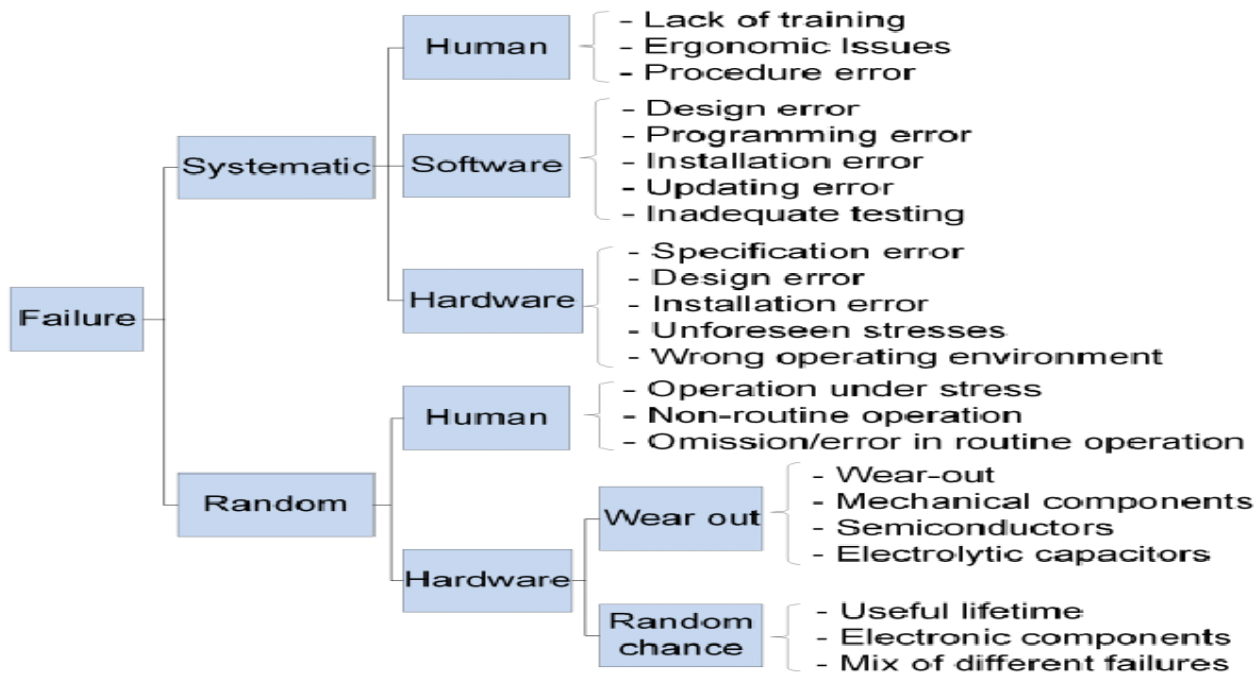

Fig. 1. Failures classification based on failure causes (sources)

The random failures occur at a random time resulting from one or more degradation mechanisms in the hardware. These failures may be caused by human error or related to the hardware of the item. The hardware related (physical) failures are divided into sudden or catastrophic failures and aging failures [7]. The catastrophic failures are modeled by the exponential distribution within the item's useful lifetime, in which the aging is negligible. Moreover, the aging failures, so-called gradual failures, are related to the wear-out phase of an item which can be modeled by the Weibull distribution. On the other hand, the systematic failures are related in a deterministic way to a certain cause, which can only be removed by a modification of the design, manufacturing process, operational procedures or other relevant factors [9]. The systematic failures have nonphysical causes, and will not reappear if the causes are appropriately corrected. Different root causes of random and systematic failures are summarized in Fig. 1 and more definition can be found in [9], [10]. In this paper, it is considered that the system is designed perfectly where systematic failures will never appear and the expert staffs are employed for operation and maintenance in order to eliminate the random human failures. Therefore, the only likely failures, which cannot be eliminated, include the random hardware failures, i.e., constant and wear-out failures as highlighted in Fig. 1.

Power electronic converters, following field data and industrial experiences, Capacitors (Caps) and Semiconductor Devices (SD) are the two most fragile components [11]–[14], which are also exposed to wear-out failures [6]. The semiconductor devices and capacitors are exposed to random hardware failures which can be single-event catastrophic failures occurred within useful lifetime and long-term wear-out failures. The wear-out failures, namely intrinsic failures, are originated by internal degradation of component materials, and hence, they can be predicted by comparing the material mechanical strength with the applied stresses. However, the catastrophic failures are difficult to predict as they are usually originated by external factors. This paper aims to predicting the reliability of power converters considering catastrophic and wear-out failures according to the accessible failure data and models for the converter components. In the following, the proposed reliability prediction method is explained in details.

III. RELIABILITY PREDICTION APPROACHES

Conceptually, failure rate of an item can be estimated by field data, test data, stress-strength analysis and/or combination of the three methods. For an item operating for a long time, the failure data can be collected and categorized following potential failure mechanisms, and hence, a complete reliability model for a specific operating condition can be provided. This approach requires long term operation of an item and accurate categorizing the failure cause and mechanisms under given operating conditions. Employing field data for the same item operating in another condition requires reasonable justification. On the other hand, by knowing the failure cause and mechanisms of an item, some tests and other accelerated tests can be designed to find out the reliability model for each mechanism. This approach relies on physics of failure analysis; hence, an accurate failure model can be obtained for an item. However, sometimes it is not cost effective to test samples of an item to understand its reliability model. Stress-strength analysis can thus be used to obtain the reliability of an item by comparing its strength to the applied stress. Strength is the designed specification of the item and stress is the loading condition. This approach requires an accurate model of the strength of the item materials. Furthermore, the combination of the three methods can also be used for predicting the reliability model of the item. Field data can be used for obtaining a reference failure rate for a component under specific conditions, (notably, this can also be provided by manufacturer). Test data can be used for modeling the impact of operating conditions on the failure rate by defining Acceleration Factors (AFs). Furthermore, the stress-strength approach can be used for predicting the item's end-of-life.

A. Constant failures

The failure rate during useful lifetime can be predicted considering the historical failure data within last operation of an item or system. The more accurate data come from the operation of system under the identical operating conditions. These type of data, so-called user-provided data [7], may be obtained based on maintenance database and shutdown reports. Moreover, in the case the reliability data are not available, some generic data provided in handbook can be employed [7]. Another data source for reliability estimation is the data prepared by the manufacturers [7]. Moreover, in most cases, especially during the design phase of new technologies, these data are not available, hence, expert judgment elicitation [7] could be the only option in which the data of similar cases may be employed by reasonable justifications. This approach is a difficult process. Some handbooks prepared methods and base failure data for components where the failure rates can be modified according to the operating conditions. It is also possible to use the manufacturer or user-provided data as the base failure rate in order to predict the failure rate under desired operating conditions. The generic failure rate data for electronic components have been provided by MIL-HDBK-217F and its modified versions. This handbook estimated the failure rate of components based on the collected data from airborne industry and generalizing it for different operating conditions including ambient temperature, operating current and voltage. Similar to this approach, Telcordia and Siemens have also provided handbook for estimating the reliability of electronic components. These approaches estimated the component and converter reliability at the rated condition. In 2004, IEC provided the TR 62380 [6] where a mission profile-based approach has been introduced for reliability estimation. Following this TR, the operating condition of a component, i.e., annual mission profile, can be classified into different phases and the total failure rate of a component is predicted based on weighted average of failure rate of each phase. Furthermore, it provided failure rate data for some components. While the data was not updated, it has been replaced by IEC 61709 in 2017 [7]. This standard provides a general mission profilebased approach for electronic components operating at different conditions. According to this standard, the failure rate of a component can be obtained as a weighted average of failure rate in different operating phases. The failure rate of each phase can be predicted based on the reference failure rate provided by manufacturer or from field data or from handbooks, which are modified according to the operating condition considering AFs. Later, the FIDES approach has been introduced where physics of failures have been taken into account for failure rate prediction of components [8]. So far, it sounds that the FIDES approach provides a complete method for estimating the constant failure rate of electronic components due to the fact it considers the statistics of different failure causes based on physics of failure analysis. However, based on the availability of data, other approaches can also be used to estimate the failure rate of components within useful lifetime.

B. Wear-out failures

The wear-out failure distribution of components can be estimated by stress-strength analysis. It requires deep understanding of the physics of failures to model the strength or lifetime of the device associated with a potential failure mechanism. Thereafter, the applied mission profile is translated to the stress on the components in order to predict the failure probability. The failure probability is defined as the probability that the applied stress is higher than the device strength as shown in Fig. 2.

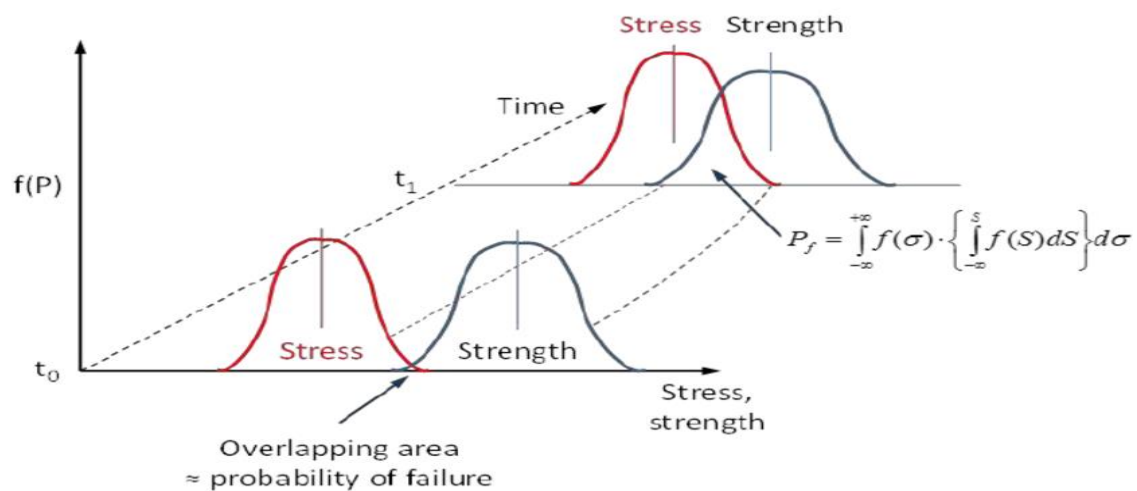

Fig. 2. Probability of failure estimation concept based on mismatch of stress and strength

In order to find the stress-strength distributions for a given failure mechanism in a component, one approach could be to perform wear-out tests for a number of samples. Another approach would be the Monte-Carlo simulations considering the modeling and manufacturing uncertainties. The first approach is employed for capacitors in this paper, while the second approach is used for semiconductors. The whole prediction procedure is described in [2], [21]–[26] and it is briefly explained in the following. The constants A , α , and β are curve fitting constants, which can be obtained from aging tests [29]. The wear-out failure prediction procedure of semiconductor switches has been described in [2], [21]–[23], where the mission profile is translated into the temperature of devices. The temperature profile is classified into different classes with specific number of cycles, temperature swing, and average temperature. For each class, the damage on the device is determined by dividing the applied stress, i.e., the number of cycles by the strength of the device, i.e., the number of cycles to failure. The device will fail if the damage increases beyond one. Therefore, the damage distribution under the given mission profile is determined for different classes. Afterwards, it is converted to an equivalent damage with the same impact on the device from a stress point of view. The statistics of uncertain parameters on the static damage can be modeled by Monte Carlo simulations, and hence, the failure distribution function is predicted for the given mission profile. Hence, the failure density function and wear-out failure rate can be obtained accordingly.

IV. CASE STUDY USING A PV INVERTER

In this paper, reliability of a double-stage PV inverter shown in Fig. 3 is predicted. The inverter includes an MPPT unit and a single-phase inverter for connecting a 2.5 kW PV array to the grid at 230 V coupling bus. The component details are provided in Fig. 3. This section includes two sub-sections; the first subsection demonstrates the impact of the operating condition on the reliability of the boost stage of the converter by experimental tests. and the second part provides the complete reliability model for the whole converter.

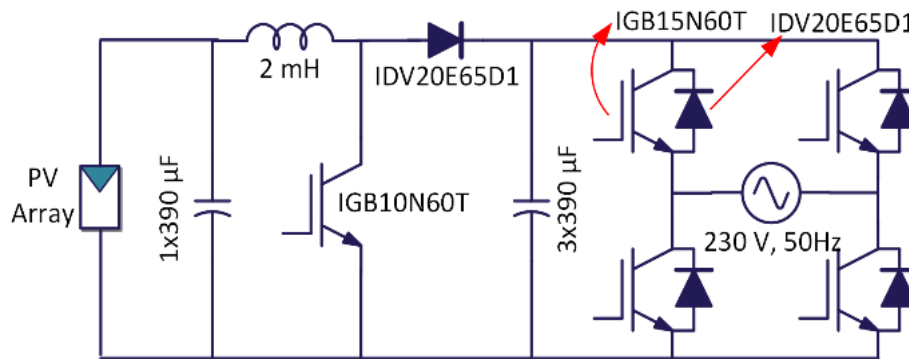

Fig. 3. Structure of the single-phase double-stage PV inverter

A. Impact of operation condition

The temperature of the device is the main factor limiting its lifetime. It depends on the operating condition and mission profiles and this fact was the motivation to include the mission profile analysis in the reliability studies. Therefore, the impact of operating condition on the temperature of the boost stage of the inverter is demonstrated. The converter is operated at 0.5 kW, 1 kW, 1.5 kW, and 2 kW load power and the temperatures are measured and reported in Fig. 4. The results show that the temperatures are highly dependent on the loading of the converter. Furthermore, the temperature rise is not linear with respect to the converter loading.

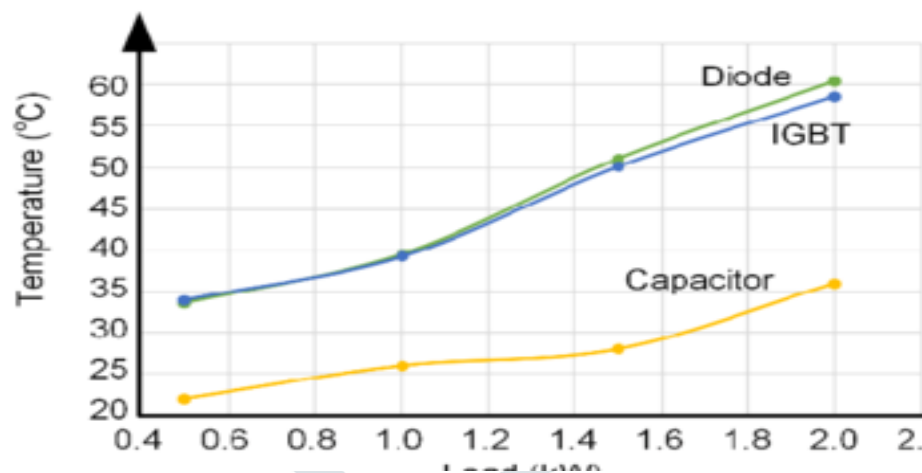

Fig. 4. Experimental results of boost converter; the IGBT, diode and capacitor temperatures under different loading conditions.

B. Comprehensive reliability prediction

The reliability of the converter is modeled by the reliability of its fragile components including semiconductors and capacitors, since these components are the most vulnerable components and prone to wear-out failures. Meanwhile, the reliability of the other components can be considered and included in the failure rate of the converter if corresponding data is available. In this paper, the impact from the other components is neglected. Furthermore, it is considered that the converter will fail if any component fails. The failure probability of converter is estimated under two different mission profiles including solar irradiance and ambient temperature of two different locations, A and B as shown in Fig. 5.

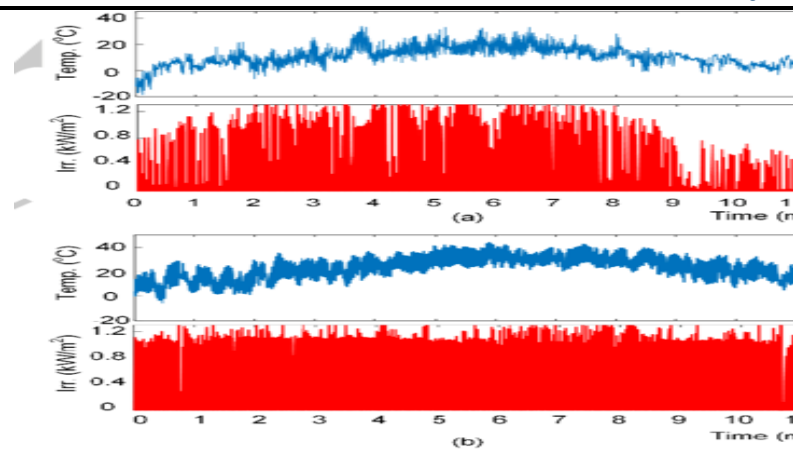

Fig. 5. Annual solar irradiance and ambient temperature for (a) Location A, (b) Location B

The constant failure rate of components including capacitors, IGBTs and diodes are estimated for both mission profiles employing FIDES approach. The total constant failure rate is calculated by summing the failure rate of all components.

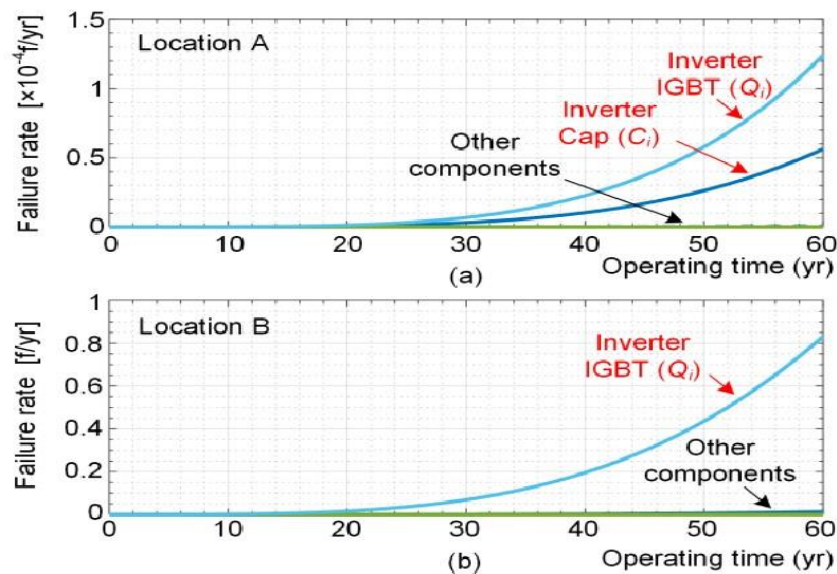

Fig. 6. Wear-out failure rate of individual components of converter under the mission profile of (a) Location A and (b) Location B.

From this case study the following results can be deduced:

1- The failure probability prediction method based on handbooks provides constant failure rate during a useful lifetime, while the period of this lifetime is not clear. However, the wear-out failure prediction defines the end of life of the converter under the applied mission profile. As a result, design of a converter which is based on constant failure rate may satisfy the target criterion, while its lifetime may not satisfy the mission period.

2- According to the importance of an application, either B1 or B10 lifetime can be used for reliability-oriented design. Employing B1 lifetime for design requires complete reliability of a converter including constant and wear-out failure rates. While for B10 lifetime, the impact of wear-out failure is dominant following Fig. 6.

3- The proposed reliability model can be employed for decision making among different alternatives /conditions, such as converter topology, impact of control, effect of environmental condition. For instance, the impact of a mission profile on the converter reliability is illustrated in this case study. The obtained results show that a converter may have different failure rates for different operating conditions. Moreover, its end-of-life is also dependent on the applied mission profile.

4- This case study also shows the dependency of the converter reliability to the operating condition, i.e., solar irradiance and environmental condition, i.e., ambient temperature. Therefore, employing the field data to predict the converter reliability and specially for power system studies such as planning and maintenance, it should be carefully justified to the operating conditions. Furthermore, employing field data of components come from different sources might also lead to wrong decision making in complex power system analysis.

V. CONCLUSION

This paper proposes a complete reliability modeling process for power electronic converters. The proposed approach considers both constant and wear-out failures of converter components, especially fragile elements such as capacitors and semiconductor switches. The proposed reliability model can be used for decision making in reliable design, maintenance scheduling, system-level planning, as well as comparing different alternatives such as topologies, control system, modulation scheme, fault tolerant approaches and so on. The proposed reliability modeling approach is applied to a single-phase PV

inverter operating under two different mission profiles. The impacts of operating and environmental conditions on the constant and wear-out failures has been illustrated implying that a converter have different failure rates under different operating conditions. Notably, the proposed method depends on the source of reliability data and employed lifetime models. The more accurate the data and lifetime models are, the more precisely the reliability can be predicted. Meanwhile, with the limited data and models, a proper decision making among different alternatives can be carried out from a reliability stand point.

REFERENCES

- [1] H. E. Johan, G. W. Steven, and H. Ramtin, "Third EGrid Workshop Maps the Grid of the Future: Attendees Engage to Examine the Role of Power Electronic Applications in Modern Electric Power Systems," *IEEE Power Electron. Mag.*, vol. 6, no. 1, pp. 48–55, 2019.
- [2] S. Peyghami, P. Davari, F. Blaabjerg, Saeed Peyghami, Pooya Davari, and Frede Blaabjerg, "System-Level Reliability-Oriented Power Sharing Strategy for DC Power Systems," *IEEE Trans. Ind. Appl.*, vol. 50, no. 5, pp. 3569–3578, 2014.
- [3] "IEEE Std 1413.1-2002 : IEEE Guide for Selecting and Using Reliability Predictions Based on IEEE 1413." IEEE, 2003.
- [4] "FIDES Guide 2009 Edition: A Reliability Methodology for Electronic Systems," 2010.
- [5] R. Billinton and R. Allan, "Reliability Evaluation of Engineering Systems." New York: Plenum press, 1992.
- [6] "IEC TR 62380: Reliability Data Handbook-Universal Model for Reliability Prediction of Electronics Components, PCBs and Equipment," 2006.
- [7] "IEC 61709 (2017): Electric Components - Reliability - Reference Conditions for Failure Rates and Stress Models for Conversion," 2017.
- [8] "IEC 61508: Functional Safety of Electrical/Electronic/Programmable Electronic Safety-Related Systems - Part 4: Definitions and Abbreviations," 2010.
- [9] R. Bayerer, T. Herrmann, T. Licht, J. Lutz, and M. Feller, "Model for Power Cycling Lifetime of IGBT Modules - Various Factors Influencing Lifetime," in *Proc. IEEE CIPS*, 2008, pp. 1–6.
- [10] M. Rausand, "Reliability of Safety-Critical Systems: Theory and Applications." John Wiley & Sons, 2014.
- [11] S. Yang, A. Bryant, P. Mawby, D. Xiang, L. Ran, and P. Tavner, "An Industry-Based Survey of Reliability in Power Electronic Converters," *IEEE Trans. Ind. Appl.*, vol. 47, no. 3, pp. 1441–1451, May 2011.
- [12] Y. Song and B. Wang, "Survey on Reliability of Power Electronic Systems," *IEEE Trans. Power Electron.*, vol. 28, no. 1, pp. 591–604, Jan. 2013.
- [13] F. Costa, "Failure Analysis of the Dc-Dc Converter: A Comprehensive Survey of Faults and Solutions for Improving Reliability," *IEEE Power Electron. Mag.*, vol. 5, no. December, pp. 42–51, 2018.
- [14] H. Wang, K. Ma, and F. Blaabjerg, "Design for Reliability of Power Electronic Systems," in *Proc. IEEE IECON*, 2012, pp. 33–44.
- [15] R. Wu, F. Blaabjerg, H. Wang, M. Liserre, and F. Iannuzzo, "Catastrophic Failure and Fault-Tolerant Design of IGBT Power Electronic Converters - An Overview," in *Proc. IEEE IECON*, 2013, pp. 507–513.
- [16] H. Wang and F. Blaabjerg, "Reliability of Capacitors for DC-Link Applications in Power Electronic Converters - An Overview," *IEEE Trans. Ind. Appl.*, vol. 50, no. 5, pp. 3569–3578, 2014.
- [17] M. Pecht and J. Gu, "Physics-of-Failure-Based Prognostics for Electronic Products," *Trans. Inst. Meas. Control*, vol. 31, no. 3, pp. 309–322, 2009.
- [18] N. Degrenne, J. Ewanchuk, E. David, R. Boldyrjew, S. Mollov, M. E. R, and D. C. Europe, "A Review of Prognostics and Health Management for Power Semiconductor Modules," in *Proc. Annual Conference of the Prognostics and Health Management Society*, 2015, pp. 1–11.
- [19] Y. Luo, F. Xiao, B. Wang, and B. Liu, "Failure Analysis of Power Electronic Devices and Their Applications under Extreme Conditions," *Chinese J. Electr. Eng.*, vol. 2, no. 1, pp. 91–100, 2016.
- [20] H. Oh, B. Han, P. McCluskey, C. Han, and B. D. Youn, "Physics-of-Failure, Condition Monitoring, and Prognostics of Insulated Gate Bipolar Transistor Modules: A Review," *IEEE Trans. Power Electron.*, vol. 30, no. 5, pp. 2413–2426, May 2015.
- [21] S. Peyghami, P. Davari, H. Wang, and F. Blaabjerg, "System-Level Reliability Enhancement of DC/DC Stage in a Single-Phase PV Inverter," *Microelectron. Reliab.*, vol. 88–90, pp. 1030–1035, Sep. 2018.
- [22] S. Peyghami, P. Davari, H. Wang, and F. Blaabjerg, "The Impact of Topology and Mission Profile on the Reliability of Boost-Type Power Converter," *IEEE Trans. Power Electron.*, vol. 31, no. 10, pp. 3052–3059, Mar. 2016.
- [23] S. Peyghami, H. Wang, P. Davari, and F. Blaabjerg, "Mission Profile Based Power Converter Reliability Analysis in a DC Power Electronic Based Power System," in *Proc. IEEE ECCE*, 2018, pp. 1–7.
- [24] P. D. Reigosa, H. Wang, Y. Yang, and F. Blaabjerg, "Prediction of Bond Wire Fatigue of IGBTs in a PV Inverter under a Long-Term Operation," *IEEE Trans. Power Electron.*, vol. 31, no. 10, pp. 3052–3059, Mar. 2016.
- [25] T. Loix, R. Belmans, and K. U. Leuven, "A Three-Phase Voltage and Frequency Droop Control Scheme for Parallel Inverters," *IEEE Trans. Ind. Electron.*, vol. 22, no. 1, pp. 1662–1667, 2007.
- [26] Y. Shen, A. Chub, H. Wang, D. Vinnikov, E. Liivik, and F. Blaabjerg, "Wear-out Failure Analysis of an Impedance-Source PV Microinverter Based on System-Level Electro-Thermal Modeling," *IEEE Trans. Ind. Electron.*, vol. 66, no. 5, pp. 3914–3927, 2019.
- [27] A. Albertsen, "Electrolytic Capacitor Lifetime Estimation," *JIANGHAI Eur. GmbH*, pp. 1–13, 2010.
- [28] D. Zhou, H. Wang, and F. Blaabjerg, "Mission Profile Based System-Level Reliability Analysis of DC/DC Converters for a Backup Power Application," *IEEE Trans. Power Electron.*, vol. 33, no. 9, pp. 8030–8039, 2018.