



## Design and Analysis of Photovoltaic based Modular Cascaded H-Bridge Multilevel Inverter

Rituja

Assistant Professor

Department of Electrical Engineering

Raja Balwant Singh Engineering Technical Campus, Bichpuri, Agra, India

**Abstract :** Multilevel inverter technology has emerged recently as a very important alternative in the area of high-power medium-voltage applications. Multilevel inverters helps in producing stepped output waveform which results in higher output waveform quality and lower distortion. This Paper presents Photovoltaic (PV) based Modular Cascaded H-Bridge Multilevel Inverter for Single- or Three-Phase Grid-Connected Applications. The modular cascaded multilevel topology helps to improve the efficiency and flexibility of PV systems. To realize better utilization of PV modules and maximize the solar energy extraction, a distributed maximum power point tracking control scheme is applied to both single- and three-phase multilevel inverters, which allows independent control of each DC-link voltage.

**IndexTerms – Cascaded H-Bridge, Multilevel, Inverters, Three-Phase, Grid-Connected.**

### I. INTRODUCTION

A multi-level converter (MLC) is a method of generating high-voltage wave-forms from lower-voltage components. A power inverter, or inverter, is a power electronic device or circuitry that changes direct current (DC) to alternating current (AC). The input voltage, output voltage and frequency, and overall power handling depend on the design of the specific device or circuitry. The inverter does not produce any power; the power is provided by the DC source. A power inverter can be entirely electronic or may be a combination of mechanical effects (such as a rotary apparatus) and electronic circuitry. Static inverters do not use moving parts in the conversion process. Power inverters are primarily used in electrical power applications where high currents and voltages are present; circuits that perform the same function for electronic signals, which usually have very low currents and voltages, are called oscillators. Circuits that perform the opposite function, converting AC to DC, are called rectifiers.

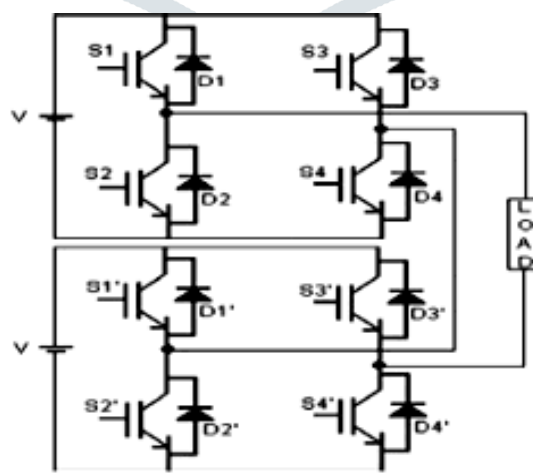

Figure 1: Five level Cascaded Inverter

Figure 1 is showing the five level cascaded inverter diagram. The cascaded multilevel inverter made of a series of H bridge (single-phase full-bridge) inverter units. Every full-bridge can produce three different voltage outputs like  $-V_{dc}$ , 0, and  $+V_{dc}$ . Though, five multilevel inverters can produce staircase waveform as. The numeral of output phase voltage levels in a cascaded multilevel inverter equation is  $2S + 1$ , here  $S$  is the number of DC sources. Every H-bridge module generates a quasi-square waveform by phase-shifting the switching timings of its positive and negative phase legs. In Cascaded H-Bridges each DC power

source is connected to an H-bridge inverter. Basically the single inverter has four switches. By using switching combinations, the single inverter can create three different AC voltage outputs.

## II. BACKGROUND

M. B. Satti et al., [1] presents the use of less number of semiconductor switches while keeping a similar number of yield voltage levels made the proposed GCPS effective, less expensive, and less complex in structure. In addition, its voltage and current THD are practically identical with the frameworks existing in the writing.

B. Sharma et al., [2] presents a control scheme for a grid-associated cascaded H-bridge multilevel inverter (CHBMLI) based sun oriented vitality change framework (SECS) tending to the issue of particular temperature and illuminations which raise to incomplete shading and board mismatch conditions in huge scope photovoltaic (PV) age.

K. Wang et al., [3] shows the plan boundaries of dc-dc converters considering the minimization of the info current wave and streamlining of switching recurrence go are talked about in detail. Reproduction aftereffects of the three-phase framework and trial consequences of the single-phase framework obviously confirm the adequacy and practicality of the proposed topology and control techniques.

A. Ahmed et al., [4] inverter switching methodology depends on programmable terminating angles. The primary dc-connection of the grid associated inverter is controlled to achieve greatest power point tracking, while the dc/dc confined converter is controlled to direct the assistant dc-joins. The proposed topology is checked by reenactment and trial results utilizing a 1.5 kW hardware model.

A. Kumar et al., [5] proposes an amazed PV association through cascaded multilevel converter (CMC) for PV-grid tie application using free greatest power point tracking controller, giving the bigger depth of activity under halfway shading condition with littler channel size and electromagnetic obstruction (EMI).

Y. Shi et al., [6] shows that the ordinary control method with momentary grid voltage feedforward (IGVF) will fundamentally restrain the bandwidth or soundness edge of a filterless grid-associated inverter, thus make the inverter delicate to grid unsettling influence. Two grid voltage feedforward control methods, which require minimal extra calculation assets, are proposed to stifle the grid voltage unsettling influence. The shut structure conditions for control boundaries are determined.

C. A. Rojas et al., [7] investigates an utility-scale photovoltaic (PV) plant setup dependent on a dc-dc stage interfaced directly to a modular multilevel converter (MMC) utilized for a HVdc power station. Since PV frameworks are dc ordinarily, the proposed arrangement has a few favorable circumstances, such as full dc activity and venture up transformers evasion with modular and solid design.

C. M. Nirmal Mukundan et al., [8] In this work a two phase Sun powered Vitality Grid Associated Framework (SEGCS) with DC-DC and Cascaded H-bridge Multilevel Inverter (CHB-MLI) for DCAC changes are proposed. The shunt associated SEGCS is shown with a non straight unbalance reactive neighborhood load. The active power produced in the Photo Voltaic (PV) framework regarding the illuminations is shared to the heap and the grid.

N. Shah et al., [9] The inverters are controlled utilizing hysteresis current controller for which the synchronizing reference currents are created utilizing p-q theory. The greatest power is extracted from the PV cluster under differing natural conditions utilizing fluffy rationale controller which creates the change in reference power to be infused into the grid by the CTLI. The CTLI based grid associated PV framework is reproduced for infusing active power delivered by the PV exhibit under fluctuating sun powered insolation just as differing load conditions.

G. Ranjith Kumar et al., [10] presents, a five-level modular cascaded H-bridge MLI is broke down dependent on grid-associated application for PV vitality framework, and an autonomous dc-interface voltage controller for each H-bridge is executed by taking the reference esteem produced from the most extreme power point tracking algorithm of each PV module.

M. A. Spirits Caporal et al., [11] In this work a grid associated photovoltaic framework is introduced. The introduced framework has two phases, the first is the MPPT system dependent on factor step with prescient current control. In the second stage an active/reactive power control is utilizations to control a multilevel inverter for grid association. All the framework is created in Matlab and reenacted on Simulink for approval.

## III. PROPOSED MODEL

The five level solar based model is designed and analysis using the MATLAB/Simulink software. The model contains PV Cell, Inverter and SVM based PWM (SPWM).

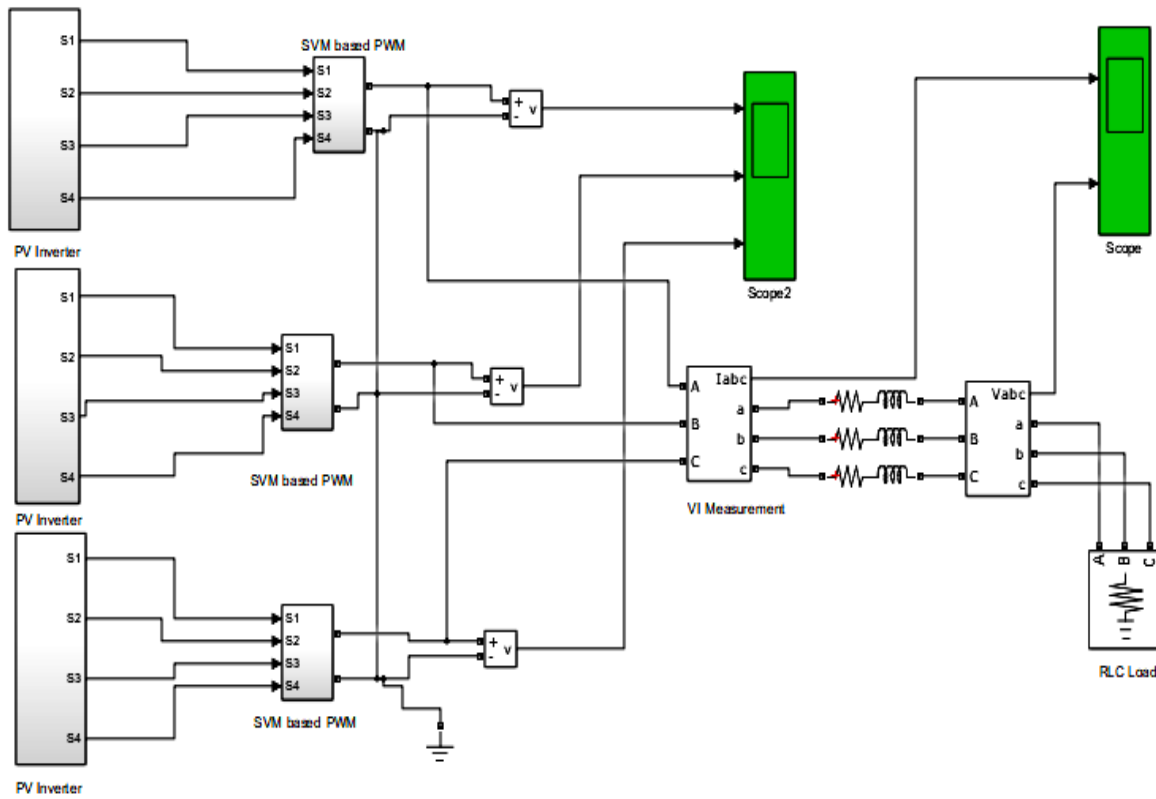

Figure 2: Proposed model

In proposed work, three phases, six switches, full-bridge inverter is used to reduce the harmonic level. The SVM technique based PWM very help full to making the switching pulse with better perform output. In this paper, constant switching frequency and variable switching frequency based on carrier pulse width modulation methods are presented and compared. A new modulation method called trapezoidal triangular multi carrier (TTMC) SPWM is implemented and compared with other methods. This new modulation method gives advantages in multilevel inverter to minimize the percentage of total harmonic distortion (THD) and to increase the output voltage.

**IV. SIMULATION RESULT**

The implementation of the proposed model is done over MATLAB 9.4.0.813654 (R2018a). The various electrical toolbox and blocks helps us to use the functions available in MATLAB Library for various design strategy.

**Case –I**

The waveform simulated value is assigned for sine wave and S1, S2, S3 and S4 carrier wave. The phase angle in rad is 0.

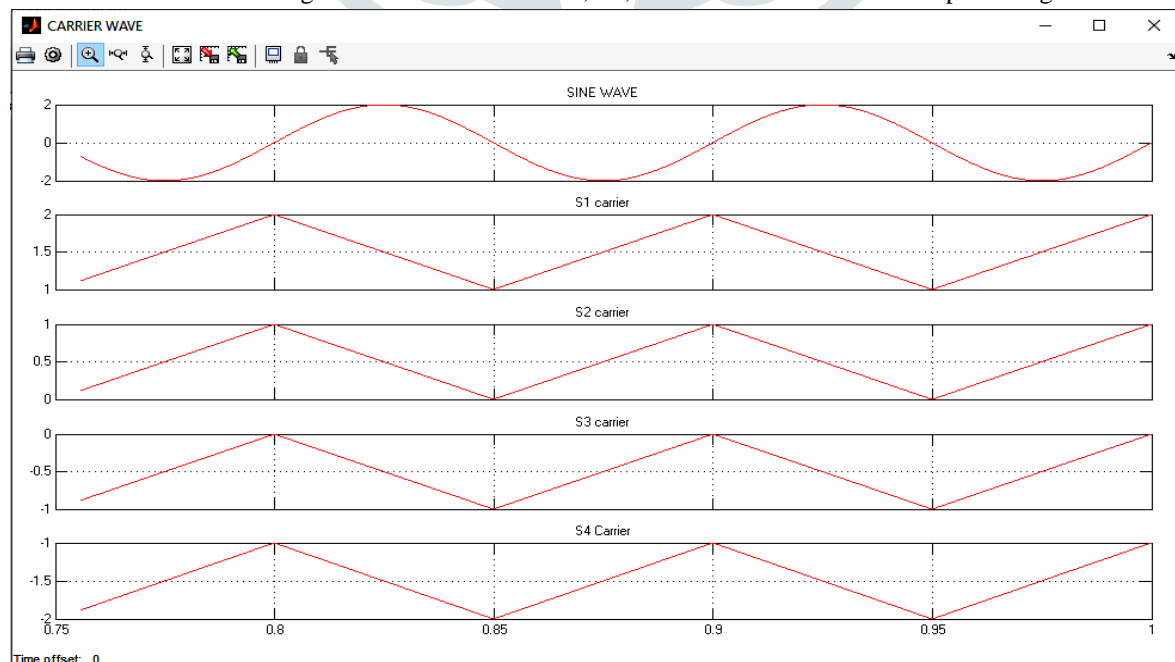

Figure 3: Sine wave and Carrier wave

Figure 3 is showing the sine wave and all carrier wave. A theoretical sine wave is an "pure" wave in that it has no harmonics and involves zero bandwidth in the recurrence space. X hub is showing the time scale and Y pivot is showing the adequacy of wave. A switching succession framed by a few switching conditions of the converter is performed and the normal estimation of the yield voltage must correspond with the ideal reference.

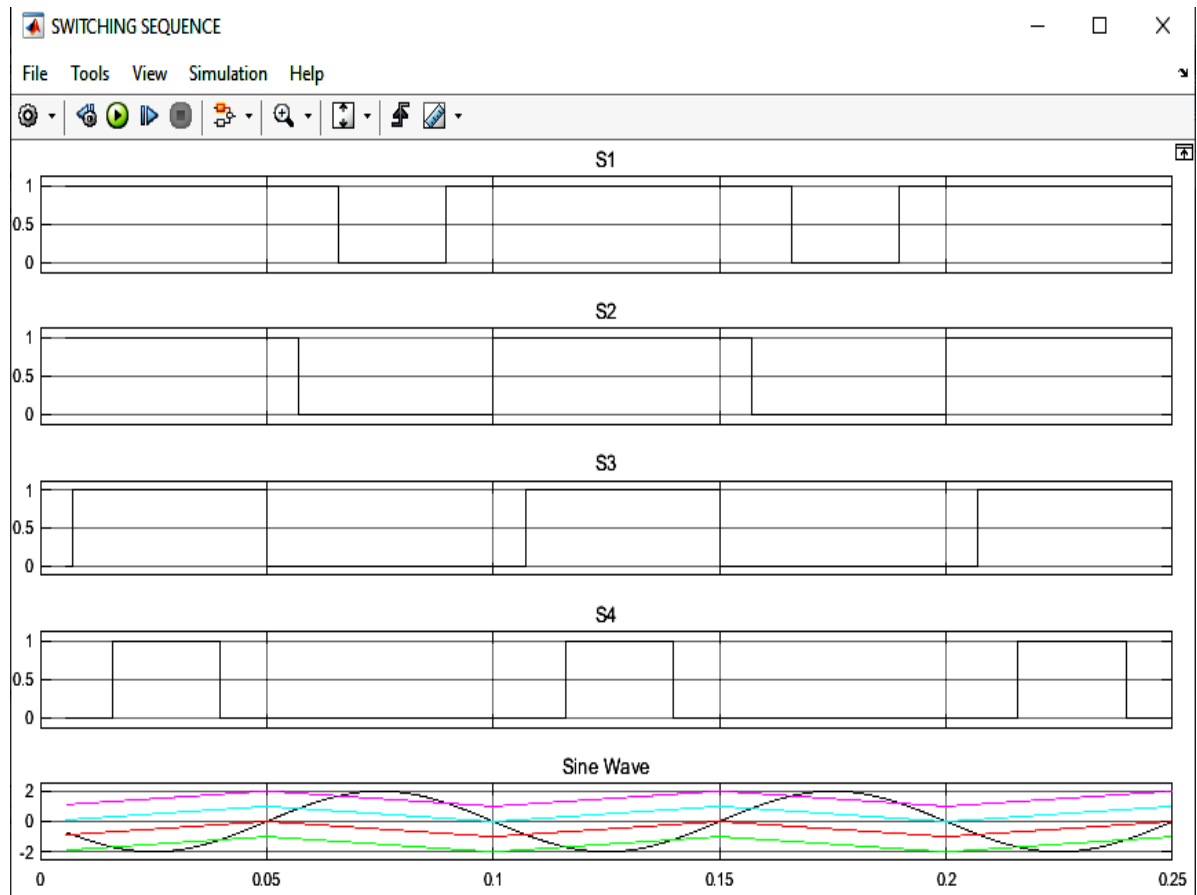

Figure 4: Switching Sequence

A switching grouping shaped by a few switching conditions of the converter is performed and the normal estimation of the yield voltage must concur with the ideal reference.

**Case –II**

The waveform simulated value is assigned for sine wave and S1, S2, S3 and S4 carrier wave. The phase angle in rad is  $2\pi/3$  or  $120^\circ$  phase shift.

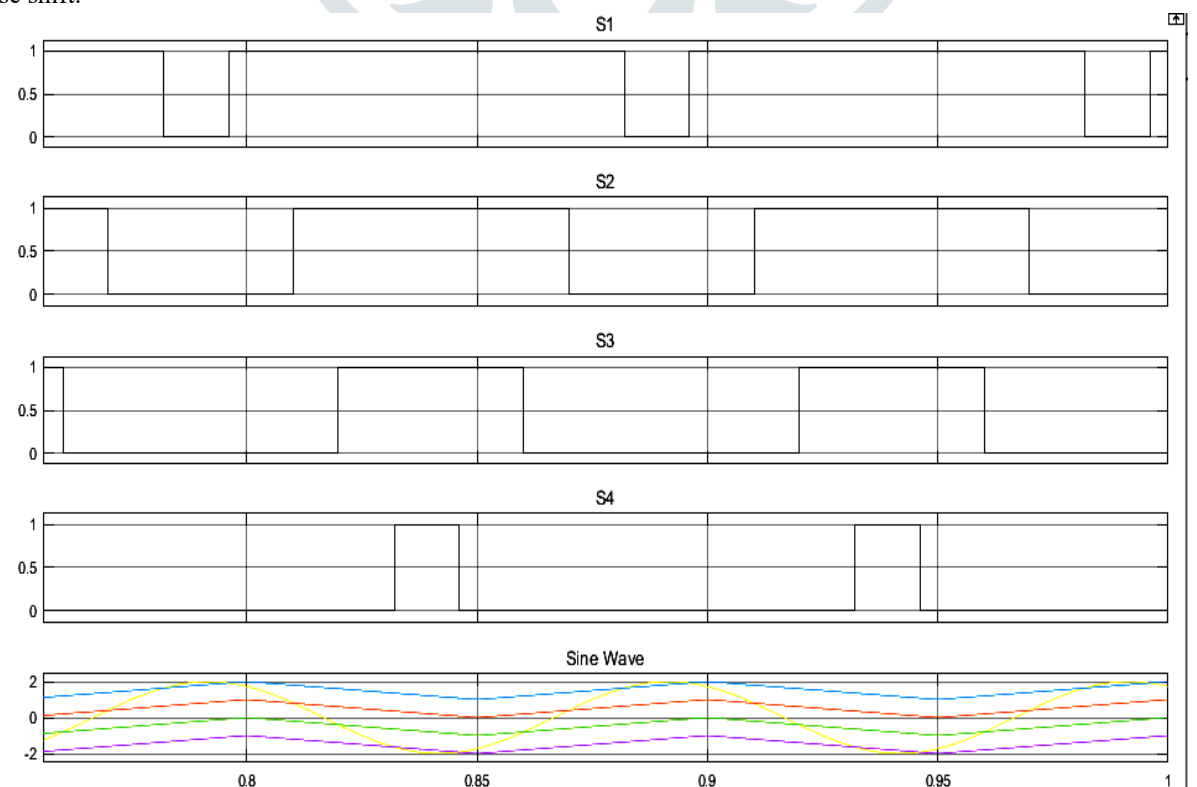

Figure 5: Switching Sequence shifted 120°

Figure 5 is showing the switching sequence of S1, S2, S3 and S4. A switching sequence formed by several switching states of the converter is performed and the average value of the output voltage must coincide with the desired reference.

**Case –III**

The waveform simulated value is assigned for sine wave and S1, S2, S3 and S4 carrier wave. The phase angle in rad is  $-2\pi/3$  or  $-120^\circ$  phase shift.

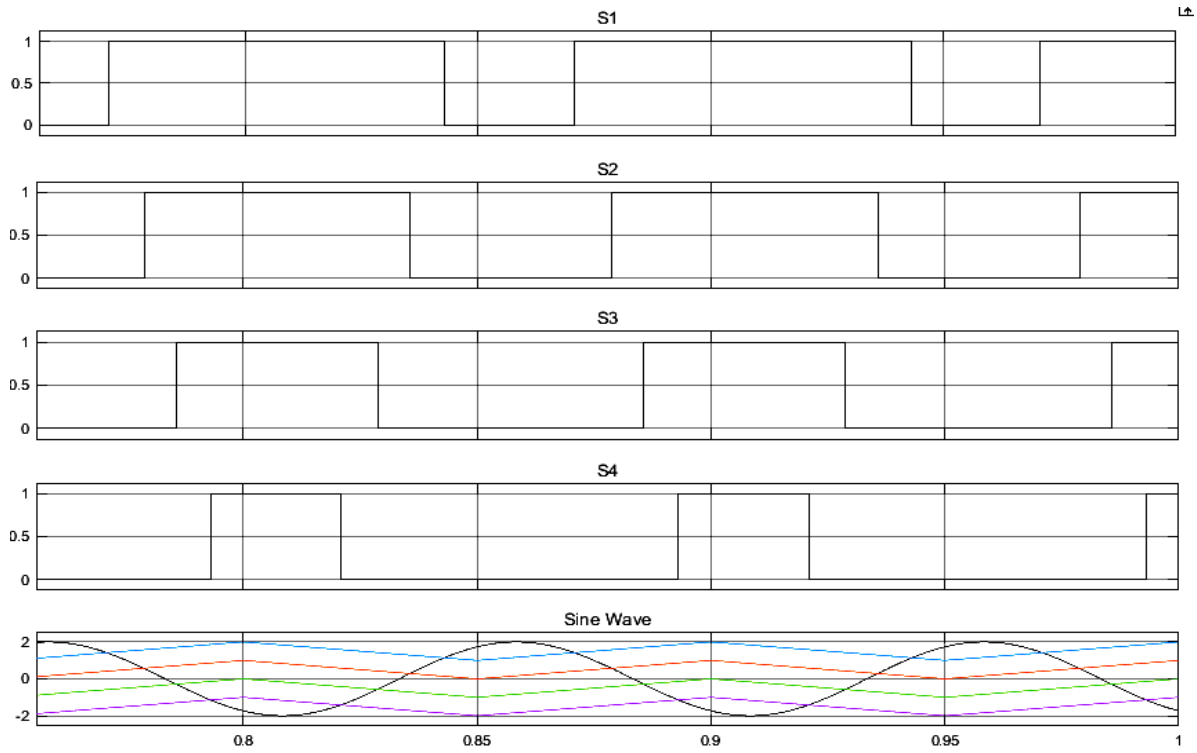

Figure 6: Switching Sequence shifted  $-120^\circ$

Figure 6 is showing the switching sequence of S1, S2, S3 and S4. A switching sequence formed by several switching states of the converter is performed and the average value of the output voltage must coincide with the desired reference.

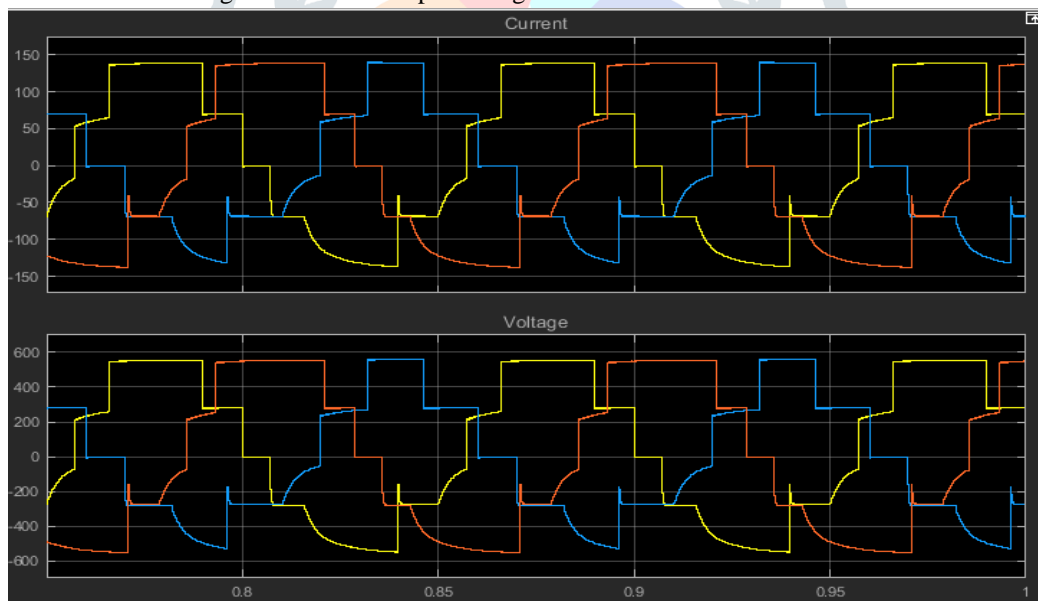

Figure 7: Inverter Output

Figure 7 is showing the multilevel inverter output current and voltage. The output voltage is 550 Voltage and current is 140 A.

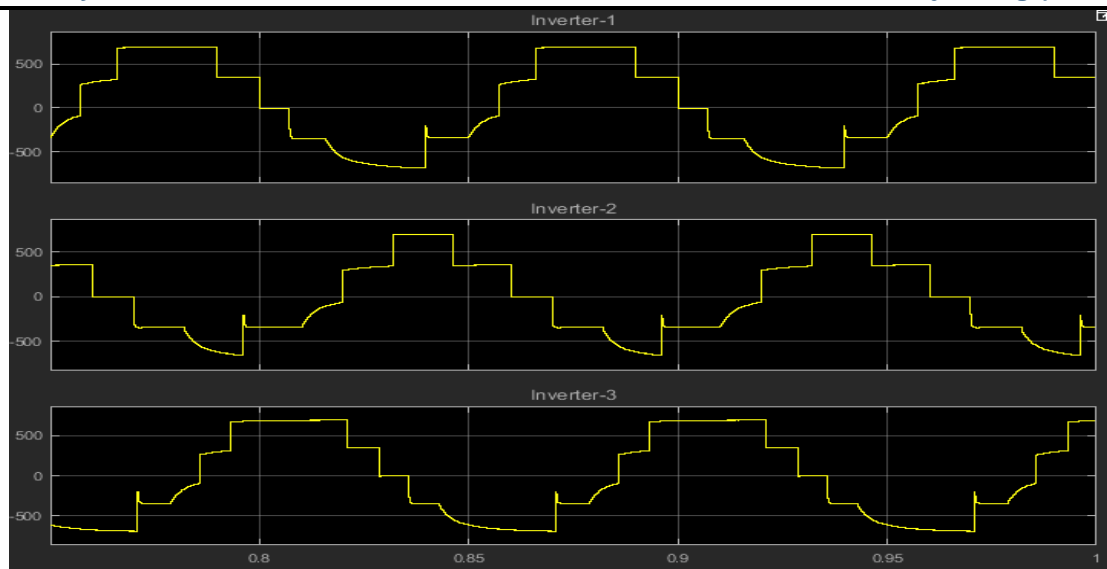

Figure 8: Inverter Voltage

Figure 8 is showing the multilevel inverter cases output voltage. All three cases have approx 550Voltage at different angle.

Table 1: Simulation parameters

Sr No.	Parameters	Proposed Work
1	PV irradiance	1000 W/m <sup>2</sup>
2	Switch	3 MOSFET and 12 IGBT
3	Inverter output voltage	550 V
4	Inverter output current	140 A
5	Inverter voltage 0 angle	550V
6	Inverter voltage +120 angle	550V
7	Inverter voltage -120 angle	550V
8	Controller	PWM

Table 1 presents simulation parameters like PV irradiance value, Inverter voltage and current and controller.

Table 2: Result Comparison

Sr No.	Parameters	Previous Work [1]	Proposed Work
1	Methodology	Grid Connected PV Systems	SVM based PWM
2	Switch per level	6	5
3	Switch type	MOSFET and IGBT	MOSFET and IGBT
4	Power (W)	600	770
5	Overall Efficiency (%)	94.26	98
6	MPPT Efficiency (%)	99.03	99.5
7	Inverter Efficiency (%)	96.33	98

The MPPT efficiency, inverter efficiency, and overall efficiency are deepened as simulation parameters. The proposed model gives MPPT efficiency is 99.5% while existing model gives 99.03% efficiency.

### V. CONCLUSION

This paper presents photovoltaic (PV) based modular cascaded H-Bridge multilevel inverter for single-or three-phase grid-associated applications. The simulated outcomes shows that the MPPT productivity, inverter effectiveness, and in general proficiency which are developed as reproduction boundaries. The proposed model gives MPPT productivity is 99.5% while existing model gives 99.03% effectiveness. The inverter productivity is 98% while existing has 96.33 and in general proficiency achieved by proposed model is 98% while existing is 94.26%. Therefore proposed model reenactment result execution is superior to past model in wording proficiency and no of switches.

## REFERENCES

1. M. B. Satti and A. Hasan, "Direct Model Predictive Control of Novel H-Bridge Multilevel Inverter Based Grid-Connected Photovoltaic System," in *IEEE Access*, vol. 7, pp. 62750-62758, 2019, doi: 10.1109/ACCESS.2019.2916195.
2. B. Sharma and J. Nakka, "Single-phase cascaded multilevel inverter topology addressed with the problem of unequal photovoltaic power distribution in isolated dc links," in *IET Power Electronics*, vol. 12, no. 2, pp. 284-294, 20 2 2019, doi: 10.1049/iet-pel.2018.5640.
3. K. Wang, R. Zhu, C. Wei, F. Liu, X. Wu and M. Liserre, "Cascaded Multilevel Converter Topology for Large-Scale Photovoltaic System With Balanced Operation," in *IEEE Transactions on Industrial Electronics*, vol. 66, no. 10, pp. 7694-7705, Oct. 2019, doi: 10.1109/TIE.2018.2885739.
4. A. Ahmed, M. Sundar Manoharan and J. Park, "An Efficient Single-Sourced Asymmetrical Cascaded Multilevel Inverter With Reduced Leakage Current Suitable for Single-Stage PV Systems," in *IEEE Transactions on Energy Conversion*, vol. 34, no. 1, pp. 211-220, March 2019, doi: 10.1109/TEC.2018.2874076.
5. A. Kumar and V. Verma, "Performance Enhancement of Single-Phase Grid-Connected PV System Under Partial Shading Using Cascaded Multilevel Converter," in *IEEE Transactions on Industry Applications*, vol. 54, no. 3, pp. 2665-2676, May-June 2018.
6. Y. Shi, L. Wang and H. Li, "Stability Analysis and Grid Disturbance Rejection for a 60-kW SiC-Based Filterless Grid-Connected PV Inverter," in *IEEE Transactions on Industry Applications*, vol. 54, no. 5, pp. 5025-5038, Sept.-Oct. 2018.
7. C. A. Rojas, S. Kouro, M. A. Perez and J. Echeverria, "DC-DC MMC for HVdc Grid Interface of Utility-Scale Photovoltaic Conversion Systems," in *IEEE Transactions on Industrial Electronics*, vol. 65, no. 1, pp. 352-362, Jan. 2018.
8. C. M. Nirmal Mukundan and P. Jayaprakash, "Cascaded H-Bridge Multilevel Inverter Based Grid Integration of Solar Power with PQ Improvement," 2018 IEEE International Conference on Power Electronics, Drives and Energy Systems (PEDES), Chennai, India, 2018, pp. 1-6.
9. N. Shah, "Multilevel Inverter Based Single-Stage Grid Connected Photovoltaic System using Cascaded Two-Level Inverter," 2018 IEEE International Conference on Power Electronics, Drives and Energy Systems (PEDES), Chennai, India, 2018, pp. 1-6.
10. G. Ranjith Kumar, G. R. Zhu, J. Lu, W. Chen and B. Li, "Thermal analysis and reliability evaluation of cascaded H-bridge MLPVI for grid-connected applications," in *The Journal of Engineering*, vol. 2017, no. 13, pp. 1595-1599, 2017.
11. M. A. Morales Caporal, J. d. J. Rangel Magdaleno, I. Cruz Vega and R. Morales Caporal, "Improved grid-photovoltaic system based on variable-step MPPT, predictive control, and active/reactive control," in *IEEE Latin America Transactions*, vol. 15, no. 11, pp. 2064-2070, Nov. 2017.
12. C. A. Rojas, M. Aguirre, S. Kouro, T. Geyer and E. Gutierrez, "Leakage Current Mitigation in Photovoltaic String Inverter Using Predictive Control With Fixed Average Switching Frequency," in *IEEE Transactions on Industrial Electronics*, vol. 64, no. 12, pp. 9344-9354, Dec. 2017.