



AUTOMATED BILLING SMART TROLLEY AND STOCK MONITORING

Angeline Beryl. J
M.E(Applied Electronics)
Dept of ECE,
LITES, Thovalai-629302.

Dr. Ferlin Deva Shahila, Ph. D
Head of Department,
Dept of ECE,
LITES, Thovalai-629302.

Mrs. Evangelin
Project Guide,
Dept of Human Resources,
LITES, Thovalai-629302

Abstract The Internet of Things (IoT) is changing human lives by connecting everyday objects together. For example, in a grocery store, all items can be connected with each other, forming a smart shopping system. In smart shopping system an inexpensive Radio Frequency Identification tag is attached to each and every product. The customers are provided with a smart shopping cart, when the customer places the product into the cart the product details such as price, count, etc., can be automatically read by the RFID which is attached to the smart shopping cart. As a result, the billing is carried out by the micro controller in the cart itself and it can be viewed through the Liquid Crystal Display in the cart. The product details (count, amount, etc.,) are transferred to the Personal Computer Billing system through Zigbee connection thereby preventing the customers from waiting in a long queue at checkout of the shop. This project is aimed at developing a hardware-based system named Stock Management System called the Blynk Application for managing the stock system of any organization. This system can be used to store the details of the stock, stock maintenance, update the stock based on the sales details, and generate sales and stock report daily or weekly based. This project is categorized individual aspects for the sales and stock management system. In this system we are solving different problem affecting to direct sales management and purchase management. Stock Management System is important to ensure quality control in businesses that handle transactions revolving around consumer goods. Without proper stock control, a large retail store may run out of stock on an important item.

Keywords: Smart Billing system, RFID tag, Zigbee, stock management system, Blynk.

I. Introduction

Objective The main objective of this project is to develop electronic device for shop's owners for stock management. In busy world, managing stocks and providing offers to the customers for each product during shopping as become tedious process. And this consumes the lot of time of the manager, admin in the shopping mall. To avoid this problem, we are proposing an automated smart stock management system. This reduces the management time of the admin in festival season. And user no longer need to know offers during billing process. The proposed system used emerging technology like Internet of Things (IoT) along with Node-MCU and RFID. RFID is used here, to uniquely identifies each item in the super market and to know about other details like price, total quantity and offers. Entire system is communicated via IoT. After the shopping is over discount can be added automatically by using Blynk App. Once the offer switch is pressed, the data is transferred, so that the customer can have a look at the entire bill and the total price based on the discount in the store. When the shopping is completed by the customer, the stock details get updated and displays the current balance stock to the admin. So, the manual work to keep on monitor the stocks is not needed when the newly designed smart trolley is used in the store. This system allows for the continuous collection of real-time data from both the offsite prefabrication facility and the construction site which can then be analyzed and used as an input to Enterprise Resource Planning (ERP) system for planning and control purposes.

II. Literature survey

Paper [1] This system represented a new methodology of smart shopping cart which saves the lot of time. The cart contains a sensor RFID tag, LCD module so that the product can be scanned in the cart and the final amount is displayed in the LCD placed in the trolley itself and there by pay only the cash at the counter. On swipe the credit cards. It will overcome the barcode technology which gets lot of problem during scanning.

Paper [2] This paper discussed a product “Smart shopping trolley for supermarkets using rechargeable smart card” being developed to help customer in terms of reduced time spent while shopping. The main objective of proposed system is to provide a technology oriented, easily handled, and efficient system for helping the customers in shopping. The main facility that the proposed model provides is the customer only needs to carry a smart card, which is needed to be swiped in the trolley to initiate shopping when a customer places a product in the smart trolley, the RFID Reader will read the Product ID and the information related to it will be stored in Arduino UNO. When shopping is over the customer have to press the end button which will automatically deduce the bill amount from the balance available in the smart card. The payment is made right there and thus avoiding the need of waiting in queue at counter and saving large amount of time. The smart card is rechargeable.

Paper [3] This system presented an alternative method of doing shopping easily as well as providing security money wise for customer satisfaction. This is implemented using android which supports NFC. In traditional way customer needs to physically purchase his product, carry cash or card along with them and wait in long queue for making payment. The application would read the product id of the product assigned in the NFC and add it to the cart in the application. The quantity of product can also be changed so the list can be edited. E-wallet facility will be given for making payment. It will also provide OTP to the customer for secure money transactions.

III. Existing system

In the existing method customer will do the shopping with Near Field Communication (NFC) enabled mobile phone. The customer should scan the products which he wants to purchase by tapping the mobile phone on NFC card attached to the product. The connection will be established with the database of the shop and the information related to the product will get displayed on the application customer is able to do payment through his mobile phone. The deployment of NFC technologies enables a mobile phone to serve as a payment device, allowing a shorter and more convenient shopping experience. Near Field Communication is a short-range high frequency wireless communication technology.

NFC is mainly aimed for mobile or handheld devices. NFC is an extension of Radio frequency identification or RFID technology. Its working distance is up to 10 cm. It operates within the globally available and unlicensed radio frequency band of 13.56 MHz, with a bandwidth of 14 kHz. It allows communication between two powered (active) devices and non-self-powered (passive) devices for simplified transactions and data exchange. The standard of the service has been improved while the supermarket can cut down its expenses on human labor. With NFC users can even pay the bills without credit card which would simplify the purchasing process.

By using Node-MCU this data is get sent to main server for fetching quantity of the item, so that discount details are displayed on the LCD. If the customer wants to remove the item from the trolley, then quantity of that item gets subtracted from the total quantity during the process. At last, the stock details get calculated in the main server. This sets the purchase in ease. It becomes easy for the store to do inventory management as all items can be automatically read and easily managed on to. The working is also simple that the admin can add products into the stock management system by using the RFID and it can be removed similarly. After the shopping is over by the customer bill with offers can be generated by using the PC. Once the bill with 12 offers is generated, the data is displayed on PC, so that the customer can have a look at the entire bill and the total price. Here the details of stock management can also be noted by the admin and plan accordingly. If there is any discount, it should be changed on the admin's page so that when the bill is received the discounted price is also calculated. This smart trolley also allows the admin to display the bill based on the available offers/discounts in the shop. Once the shopping is over and the payment is done the admin can reset the particular trolley by clearing the data through the webpage, so that the next customer can use immediately.

Web Service: Web service is used for connectivity any device with any other device with active internet. HTTP protocol is used for communication. In this proposed method web service is needed to establish communication between mobile phones and mall's database to get information of product, customer details and payment details.

Database: The system's database consists of following tables:

- Product: It provides detail information about its product id, product name, mfg. date, exp date, price, etc.
- Admin: This table will have information about admin id, admin name and login id.
- Customer: This table maintains customer id, customer name, their email id and mobile no.
- Store: This table maintains store id, store location, product id and product name.
- Balance: It provides information about previous balance and updated balance of customers.

The details of the product will be displayed on user's mobile phone. The user will enter the quantity they want to purchase and can also view list of all products with price that have added in cart. Then the user will make the payment by e-wallet. And then the order will receive at admin side and then he will deliver product manually. After that admin will also recharge customer's account as per their request. NFC is a specialized subset within the family of RFID technology. Specifically, NFC is a branch of High-frequency (HF) RFID, and both operate at the 13.56 MHz frequency. It only enables short-range communication between compatible devices. NFC technology utilizes only an alternating magnetic field, meaning that no power is emitted in the form of radio waves. This prevents any interference from occurring between similar devices or any radio communications operating at the same frequency.

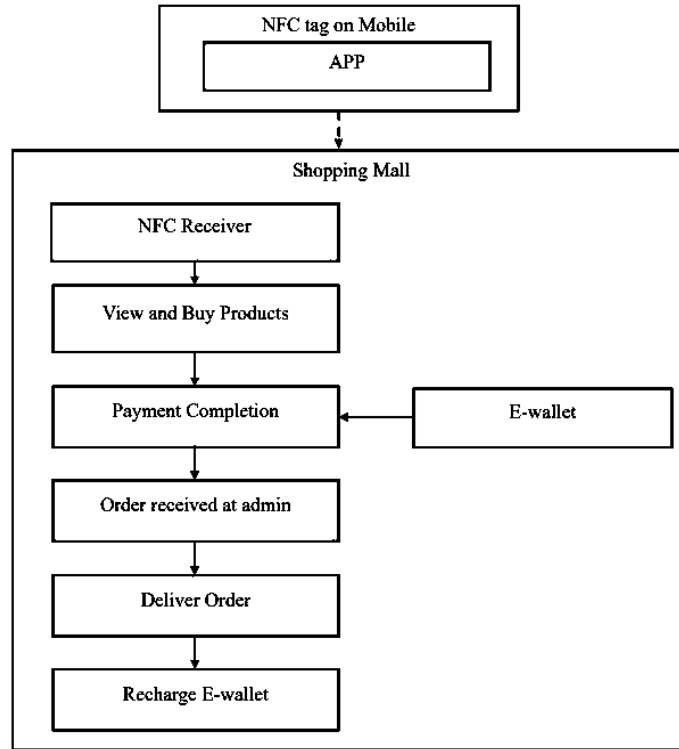

Block Diagram of Existing System

Advantages & Disadvantages:

Adv:

- Reduces scanning time
- Personalization of items
- Maintains History of purchased products
- Provides information regarding Discounts and Offers.

Disadv:

- It is applicable only for NFC enabled mobile phones
- Need Specific Android Application
- Superintendence of e-tags and lack of research in NFC terminals.

IV. Proposed system

The proposed system consists of Radio Frequency transmitter, receiver, Node-MCU microcontroller and Liquid Crystal Display. So, each stock will send the stock information to the admin server for calculating the quantity of purchased stocks. To send information of each trolley we are using inbuilt Wi-Fi. Working is started when the admin purchased stocks for the supermarket. The RF receiver in the stock management is paired to inbuilt Wi-Fi and Liquid Crystal Display for stock bill generation. When the admin puts the items the RF receiver reads the data from the RF transmitter which is attached on the product, then it is send to the Blynk App through the microcontroller.

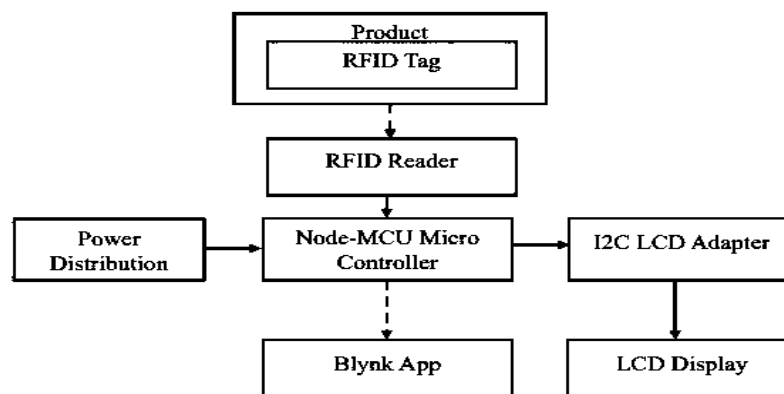

Block Diagram of proposed System

The block diagram consists of a Node-MCU microcontroller, LCD display and RFID. When the product is dropped the RF receiver scans the RF transmitter on product without requirement of line-of-sight communication. RF receiver sends information of each

scanned product to the Node-MCU microcontroller. Total quantity is displayed on LCD on the admin section. When a person is done with the shopping, she/he has to enter an information about payment completion in the keypad. Further this information regarding price and number of products is transferred to the central PC through Internet. At the same time billing information is also updated through Node-MCU (ESP8266). So that the admin can check stock availability, update discount for the products in festival season and also keep monitoring minimum quantity of stocks through webpage.

The information is collected from respective RFID, which is to be interfaced to IOT module to the web page. Web page shows the graphical representation of the inventory in the shopping mall. In various shopping mall, system is used to calculate the stocks in the billing section, when the user buying the respective inventory, it will automatically deduct the quantity in the system in real time. But in this system, internet is used to monitoring in the form of web page to managing various inventory at the same time indication.

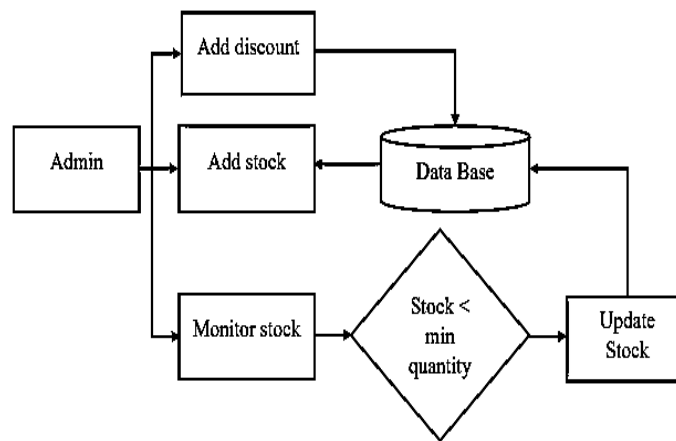

Block Diagram of Stock Monitoring

V. Hardware implementation

Hardware used to implement this IoT based Automated billing smart trolley system are:

- Power source
- Rectifiers
- Filters
- Transformers
- Regulator
- Node-MCU microcontroller
- Radio-Frequency Identification (RFID)
- ESP8266 Module
- LCD Display
- Personal Computer

- **Node-MCU:** is an open-source firmware and development kit that helps to build IoT product. It includes firmware which runs on the ESP8266 Wi-Fi SoC from Espressif Systems, and hardware which is based on the ESP-12 module.

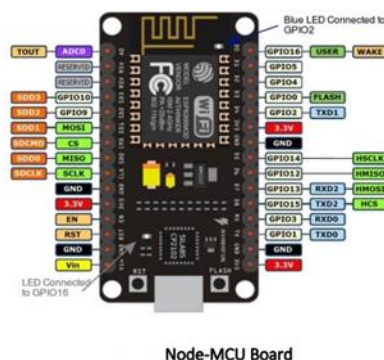

The firmware uses the Lua scripting language. ESP8266 is a low-cost, Wi-Fi Module chip that can be configured to connect to the Internet for Internet of Things (IoT). Node-MCU is an open source IoT platform. It includes firmware which runs on the ESP8266 Wi-Fi SoC from Espressif Systems, and hardware which is based on the ESP-12 module. The term “Node-MCU” by default refers to the firmware rather than the dev kits. It is based on the Espressif ESP8266-12E Wi-Fi System-On-Chip, load with an open-source, Lua-based firmware. It’s perfect for IoT applications and other situations where wireless connectivity is required. This chip has a great deal in common with the Arduino – they’re both microcontroller-equipped prototyping boards which can be programmed using the Arduino IDE.

The board can operate on an external supply of 6 to 20 volts. If supplied with less than 7V, however, the 5V pin may supply less than five volts and the board may be unstable. If using more than 12V, the voltage regulator may overheat and damage the board. The recommended range is 7 to 12 volts. The GPIO (General Purpose Input/Output) allows to access to pins of ESP8266, all the pins of ESP8266 accessed using the command GPIO, all the access is based on the I/O index number on the Node-MCU dev kits, not the internal GPIO pin.

- **Radio-frequency identification (RFID)** is the use of an object (typically referred to as an RFID tag) applied to or incorporated into a product, animal, or person for the purpose of identification and tracking using radio waves. Some tags can be read from several meters away and beyond the line of sight of the reader. RFID is more suited to faster moving environments with lots of moving plants and is most often used for vehicle access control, moving trolley and asset management purposes. Most RFID tags contain at least two parts. One is an integrated circuit for storing and processing information, modulating and demodulating a radio-frequency (RF) signal, and other specialized functions. The second is an antenna for receiving and transmitting the signal. RFID stands for Radio-frequency identification. It refers to a technology, where digital data is encoded in RFID reader using radio waves. It is similar to barcoding in which data from tag is decoded by an RFID reader device.



RF Transceiver Module

- **Arduino Uno** is a microcontroller board based on the ATmega328 (datasheet). It has 14 digital input/output pins (of which 6 can be used as PWM outputs), 6 analog inputs, a 16 MHz crystal oscillator, a USB connection, a power jack, an ICSP header, and a reset button. simply connect it to a computer with a USB cable or power it with an AC-to-DC adapter or battery to get started. It features the Atmega8U2 programmed as a USB - to -serial converter.



The Arduino Uno can be powered via the USB connection or with an external power supply. The power source is selected automatically. External (non-USB) power can come either from an AC-to-DC adapter (wall-wart) or battery. The adapter can be connected by plugging a 2.1mm centre-positive plug into the board's power jack. Leads from a battery can be inserted in the Gnd and VIN pin headers of the POWER connector.

- **ZigBee module** is an IEEE based specification for high-level communication protocols used to create personal area networks with small, low-power digital radios, such as for home automation, medical device data collection, and other low-power low-bandwidth needs. The technology defined by the ZigBee specification is intended to be simpler and less expensive than other wireless personal area networks (WPANs), such as Bluetooth or Wi-Fi. Applications include wireless light switches, electrical meters with in-home-displays, traffic management systems, and other consumer and industrial equipment that require short-range low-rate wireless data transfer. Data transmission rates vary from 20 kilobits/second in the 868 MHz frequency band to 250 kilobits/second in the 2.4 GHz frequency band. Zigbee is used in applications that require only a low data rate, long battery life, and secure networking.



Zigbee is a wireless technology standard that is well suited for short-range wireless communications. It works by the coordinator, situated at the root of the Zigbee network, sending a message to a router which then passes the message on to an end device with instructions to perform a specific communication. A typical Zigbee network contains 3 different types of devices that is 1) a coordinator, 2) routers 3) end devices.

VI. Hardware setup & Working

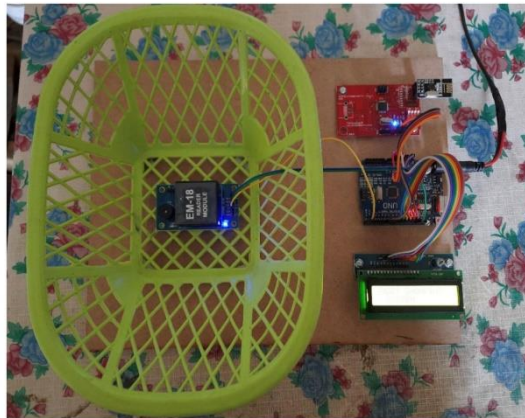

Step1: Once the system is powered up & initialized the system is ready for scanning products. Now the shopper has to scan the membership card. On purchasing of product and adding products into the cart the total amount will be calculated automatically and the amount detail will be displayed on the LCD Display.

Step2: open admin page in the PC which displays a dialog box. In the dialog box enter the trolley number before starting to update trolley details. The amount tab contains Serial No, Name, Amount details and CRUD buttons. Next enter Serial No, Name and Amount after clicking ADD button.

If the customer needs to 49 modify the amount details, then press the update button.

To delete the entered details, click the delete button.

Step 3: The trolley with microcontroller transfers all the scanned product details into the PC. The stock details tab includes Serial No, product name, price and CRUD buttons.

To add new product new button is pressed. Update button is used to modify the added stock product details and delete button is used to delete the unwanted added products in stock.

After purchasing the total amount for the purchased product will be calculated and displayed to the customer on the PC screen. This screen contains serial no, product name, price and the total amount.

Step 4: To make payment the customer needs to press the payment button, the total amount for the purchased product will be debited. The shopping payment is debited from the customer's debit card after the payment button is pressed. After successful payment, the successful message including name, bill amount, amount in the debit card and balance amount in the debit card after purchasing will be displayed.

Step 5: When a product is scanned all its details will be fetched by microcontroller & displayed on the LCD screen including total quantity & discount offers.

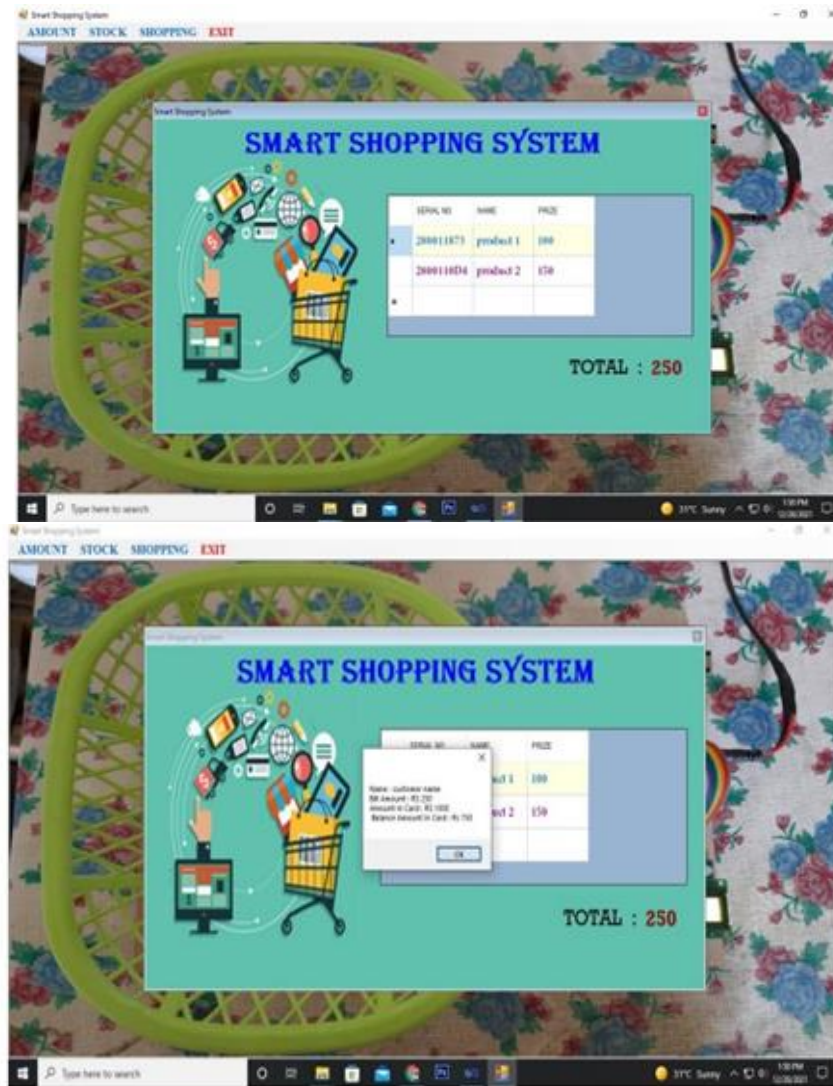

VII. Software implementation

Step 6: On purchasing of product and adding products into the stock management section the total quantity will be calculated automatically and the total amount detail will be displayed on the Blynk App.

The PC displays the following actions such as 10 percent discount, Amount, Display, Product Name, Total Amount and Stock Monitor details.

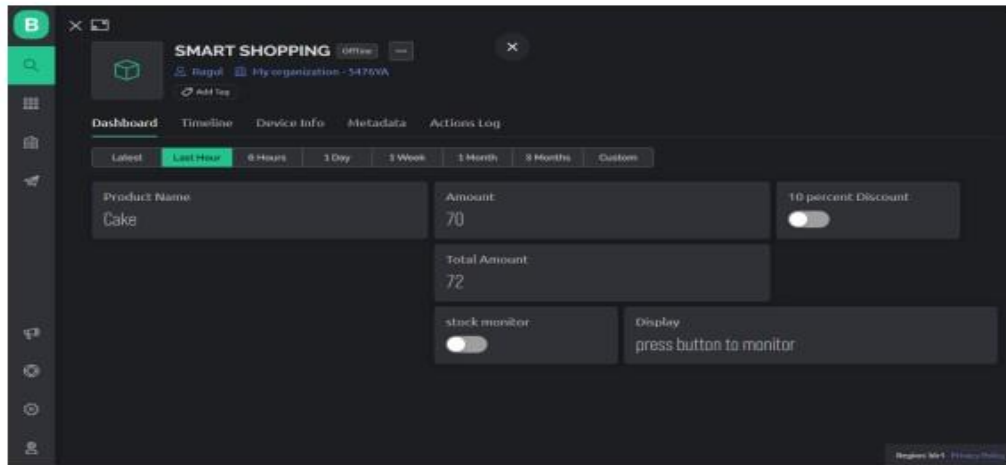

Display Discount Amount details on Blynk App

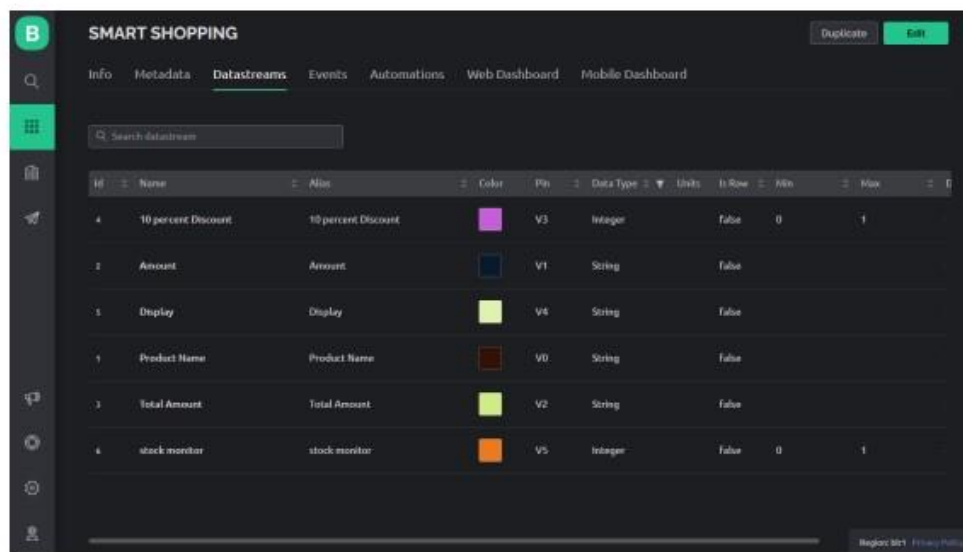

List of Stocks

Conclusion

In this proposed system, the successful use of RFID system for smart shopping trolley has been demonstrated. The items can be detected irrespective of its tag orientation. These were the drawbacks addressed in previous shopping trolley applications which were overcome in this application. It will enable online transaction procedure for billing, and it will also give suggestions to the user for buying products, display offer set... Secondly, RFID tags and ZigBee should work properly in this project. Further, a more sophisticated Arduino micro-controller and larger display system can be used to provide better consumer experience. The proposed system can use RFID that allows scan every product so that the admin to view the stock details also. Details of stock management will also be noted by the admin and plan accordingly. If there is any discount, it should be changed on the admin's page so that when the bill is received the discounted price is also calculated. This smart trolley also will allow the admin to display the bill based on the available offers/discounts in the shop.

References

1. Ankush Yewatkar, Faiz Inamdar, Raj Singh, Ayushya, Amol Bandal (2016), "Smart Cart with Automatic Billing, Product Information, Product Recommendation Using RFID & Zigbee with Anti-Theft", 7th International Conference on Communication, Procedia Computer Science, Vol. 79.
2. Prabha K.R, Sabari Manoj S, Sandeep C, Maniganda Dinesh M.R (2017), "Smart shopping trolley for supermarkets using rechargeable smart card", International Journal of Scientific & Engineering Research Volume 8, Issue 7.
3. Ou Wenxing, Wang Lei, Jiang Zhipeng, Yu Changhong (2015), "Implementation of Smart Shopping System based on NFC Technology", IEEE Seventh International Conference on Measuring Technology and Mechatronics Automation.

4. Tangtisanon, P., 2018, April. Web Service Based Food Additive Inventory Management with Forecasting System. In 2018 3rd International Conference on Computer and Communication Systems (ICCCS) (pp. 448- 452). IEEE.
5. Ignaciuk, P. and Wieczorek, L., 2019. Networked base-stock inventory control in complex distribution systems. *Mathematical Problems in Engineering*, 2019.
6. HR, G. and Aithal, P.S., 2020. Integrated Inventory Management Control Framework. *International Journal of Management, Technology, and Social Sciences (IJMTS)*, 5(1), pp.147-157.
7. Botha, A., Grobler, J. and Yadavalli, V.S., 2017. System dynamics comparison of three inventory management models in an automotive parts supply chain. *Journal of Volume 7, Issue 2, March-April-2021 | http://ijsrcseit.com Balavishnu Metal Int. J. Sci. Res. Comput. Sci. Eng. Inf. Technol, March-April-2021, 7 (2): 250-262 347 Transport and Supply Chain Management, 11(1), pp.1-12.*
8. Pando, V., San-Jose, L.A., Sicilia, J. and Alcaide-Lopez-de-Pablo, D., 2021. Maximization of the return on inventory management expense in a system with price and stock-dependent demand rate. *Computers & Operations Research*, 127, p.105134. 60.
9. Kara, A. and Dogan, I., 2018. Reinforcement learning approaches for specifying ordering policies of perishable inventory systems. *Expert Systems with Applications*, 91, pp.150-158.
10. Diamant, A., Milner, J., Qureshy, F. and Xu, B., 2018. Inventory management of reusable surgical supplies. *Health care management science*, 21(3), pp.439- 459.
11. Nemptajela, N. and Mbohwa, C., 2017. Relationship between inventory management and uncertain demand for fast moving consumer goods organisations. *Procedia Manufacturing*, 8, pp.699-706.
12. Vinushree R, Rangeetha S (2015), "ARM7 Based Web Enabled Smart Shopping Trolley", *International Journal of Innovative Research in Technology*, Volume 1 Issue 12.
13. Prince Samuel S, Kamalamoorthy N and Karthikeyan N (2015), "Smart Shopping Cart", *International Journal on Recent and Innovation Trends in Computing and Communication*, Volume: 3 Issue: 10.
14. Satish Kamble, Sachin Meshram, Rahul Thokal, Roshan Gakre (2014), "Developing a Multitasking Shopping Trolley Based on RFID Technology", *International Journal of Soft Computing and Engineering (IJSCE) ISSN: 2231- 2307, Volume-3, Issue-6.*
15. Surya Prasad, Praveen Kumar B O, Roopa D & Arjun A K (2011), "Novel Low-Cost Intelligent Shopping Cart", IEEE.
16. Swati Jadhav, Sneha Kamath, Sonam Yadav, Amruta Rajput, Prof. K. S. Sakure (2018), "Smart Shopping Application using NFC", *International Research Journal of Engineering and Technology (IRJET)*, Volume: 05 Issue: 03.
17. Thakur Prerana, Shikha Ranjan, Prachi Kaushik (2017), "Smart Shopping Cart for Automatic Billing In Supermarket", *International Journal of Engineering Development and Research*, Volume 5, Issue 2.