



## ROTOR WITH GUIDE VANES ANALYSIS OF MULTISTAGE CENTRIFUGAL PUMP USING FEA

Naga Sai Akhil.B<sup>1\*</sup>, G Navaneetha Krishnan<sup>2</sup>, T.Seshaiah<sup>3</sup>

<sup>1</sup>M.Tech PG Student, Department of Mechanical Engineering, QIS College of Engineering & Technology, Ongole

<sup>2,3</sup>Assoc.Professor, Department of Mechanical Engineering, QIS College of Engineering & Technology, Ongole

### ABSTRACT

In this paper presents the 3D modelling and Computational Fluent Analysis (CFA) of hydraulic parts of the submersible centrifugal pump unit has been considered. For this study a rotor with impeller, diffuser and return channel has been taken. The CAD models of submersible centrifugal pump unit consists of rotor with impeller, diffuser and return channel were created with the help of CATIA V5 software and Fluent Analysis is also carried out to create fluid domain with the help of numerical computations and flow non-uniformities are identified in return channels to reduce the bouncing, stability and improve the efficiency of guide vane geometry with rotor of centrifugal pump.

*Keywords: submersible centrifugal pump, CAD Model, Guide vanes, impeller, return channels, Diffuser, Fluent ANSYS*

### 1. Introduction

Multi stage centrifugal pump one of the key device for fluid transport, has been widely used in many industry fields such as chemical engineering, thermal power and petroleum. The safe and smooth running of coupled rotor system with guide a vane directly influences the stability and increases the efficiency of multistage centrifugal pump unit[1-2].evaluated stiffness and damping coefficients of mechanical seals, bearings, throttle seals and wear rings for to reduce the resonance conditions[3]. Investigated the range and magnitude of energy losses in the multistage centrifugal pump were analysed in the guide vanes area [4].studied 1D numerical model of EPFL technical platform can be utilized to identify the transient responses of the Hydro power plant machineries [5].studied about the centrifugal pump type impeller performance in terms of von misses stresses, strains, deformation and natural frequency and mode shapes for different materials taken into consideration[6] studied the CFD analysis of centrifugal pump in terms of volute flow and impeller-volute interactions for improvement of the pump performance[7] investigated the dynamic behaviour of multistage centrifugal pump rotor system in terms of efficient or accurate range of critical speed determined by using Monte Carlo method [8] discussed the differences between the traditional and compact machines influences on dynamic characteristics of efficiency stages [9] studied the analytical solutions of two different bearings (Rigid and flexible) in the form of lateral vibration characteristics by using Dunkerley's method[10]. Investigated amplitude- frequency characteristics of rotor have been determined

by using the Lanczos Method [11]. Based on the exhaustive literature survey no author has been to design and fluent analysis of multistage centrifugal pump unit of petroleum, chemical Engg and oil refineries. Finally in this paper to calculate carried out to create fluid domain with the help of numerical computations and flow non-uniformities are identified in return channels to reduce the bouncing, stability and improve the efficiency of guide vane geometry with rotor of centrifugal pump.

## 2. CAD Models of Impeller and Guide Vanes

Then, impeller blades and guide vanes which were designed by manufacturer are extracted from filled bodies (Figure 2.1(a), 2.1(b) and assembled in the way that fluid can travel as in Figure 2.1 (d). Additionally, two extension pipes whose lengths are  $3D$  and  $6D$  are attached to inlet and outlet respectively. These pipes are crucial in order to diminish the boundary condition effects and obtain accurate results. The computational domain of 5-stage pump is shown in Figure 2.1(c).

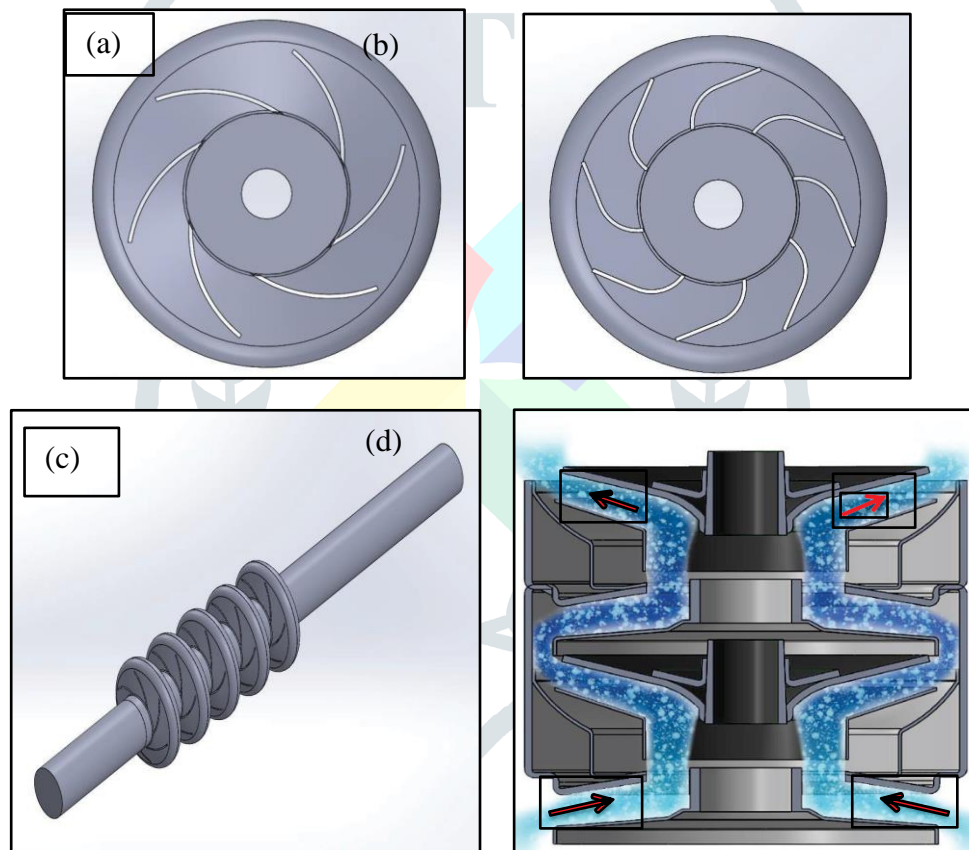

Figure 2.1 Fluid domain models of impeller (a) Top view of impeller zone, (b) Top view of guidevane zone, (c) Isometric view of five stages with extension pipes (d) flow through impeller and guide vane channels.

### 3. Meshing

Mesh network can be seen in Figure 3.1(a). The size difference between zones is resulted from different size functions. The average mesh sizes of stages and extension pipes are adjusted as 2mm and 5mm respectively. In Figure 3.1(b), the difference is seen more detailed. Elements are formed smaller in vaned areas due to the proximity function.

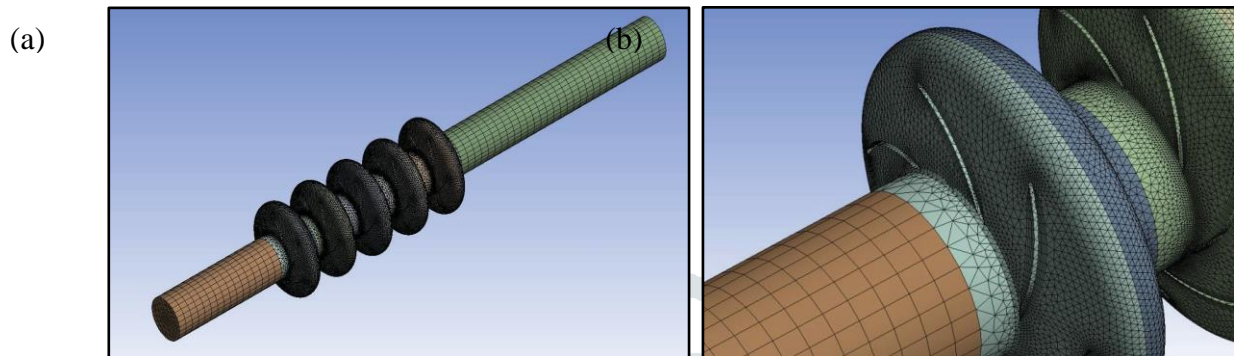

Fig. 3.1 Computational domain mesh

Since the near wall region of the boundary layer will be modeled by a wall function, first cell should not be in this layer. Therefore, in this study mesh value is taken as 30 and therefore, the first cell height became 0.1 mm as shown in Fig.3.2

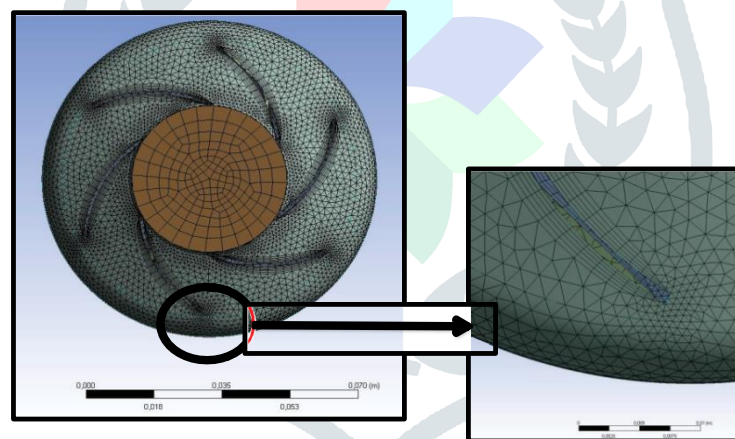

Fig 3. 2 Boundary layer mesh near impeller blades.

Fig 3.3 shows the boundaries of the computational model and conditions are defined based on assumptions and pump characteristics. It is assumed that the pump operates in ditch water at fluid level, so it is accepted that the total pressure at the inlet boundary is 0 Pa. When defining the outlet boundary conditions, pump capacity at the best efficient point is based on and 8 tons/h which is 2,222 kg/s of outlet flow is accepted

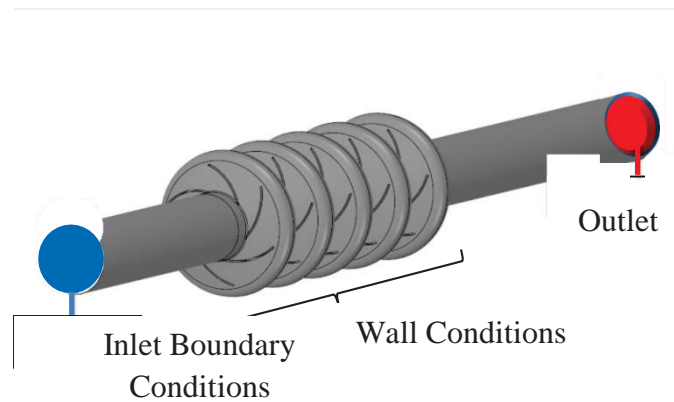

Fig.3. 3 Demonstration of boundary conditions on fluid domain

#### 4. Results and Discussions

A typical total pressure development along a 5-stage pump is shown in Fig. 4.1. It indicates that the flow development is in the desired manner. It is inferred clearly from the color changes, total pressure of the fluid increases through stages. The bar chart in Fig.4.2 shows the contribution of each stage with respect to the total pressure gain. There is not any significant difference between stages, this means each stage affect the pressure rise equally as it should be.

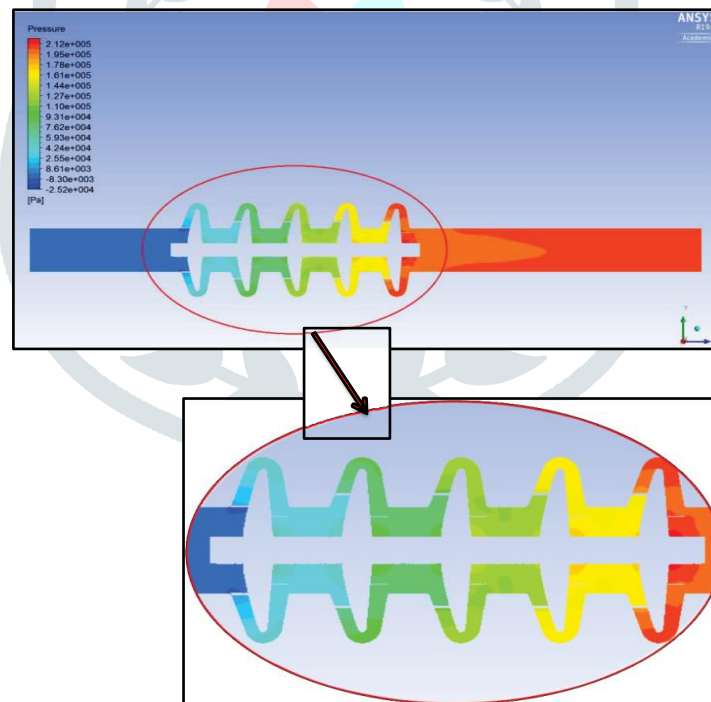

Fig.4.1 Pressure generation through stages

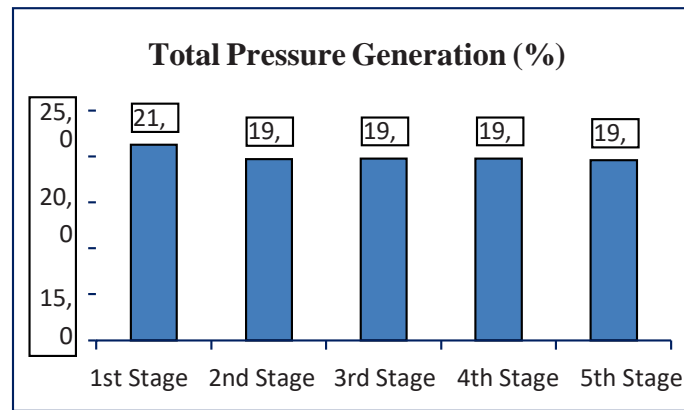

Fig.4.2 Pressure generation of each stage

In Fig.4.3, velocity streamlines at impeller section are shown. It can be seen that, the relatively uniform flow is seen between the impeller blades is not similarly observed between guide vanes. Small, but important, swirls occurring at pressure sides on the guide vanes can clearly see in the Fig 4.4 As it is understood from the locations of the swirls, the main reason of this is the sharp curved geometry of the guide vanes. Apart from the streamline visuals, the performance parameters for best efficient point of 5-stage model are shown in Table 4.1

Table 4.1 Performance parameters of original design

Total head (m)	21.6
Hydraulic efficiency	0.63
Loss coefficient	0.92

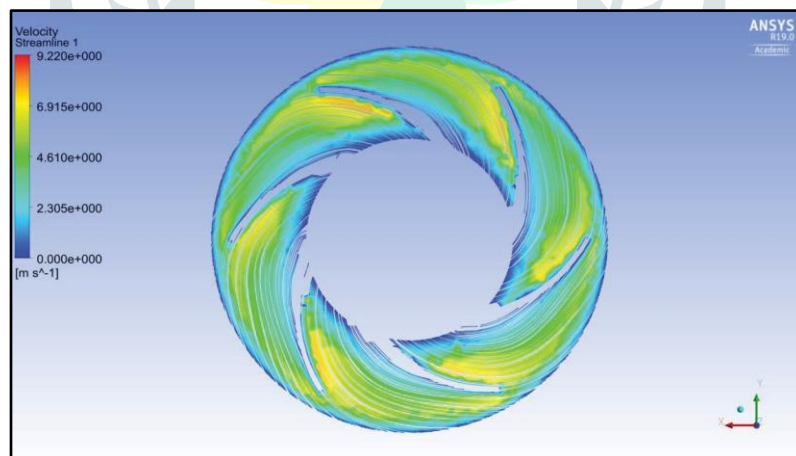

Fig. 4.3 Velocity streamlines of original design at impeller section

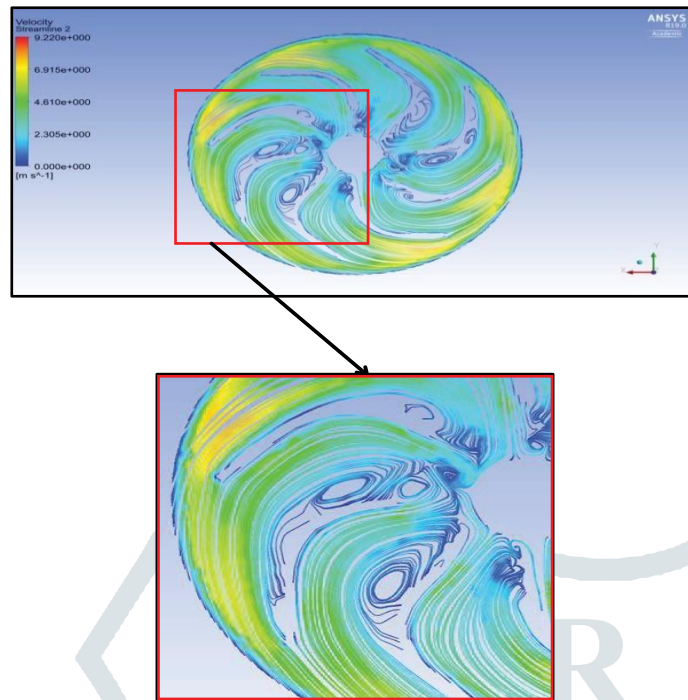

Fig. 4.4 Velocity streamlines of original design at guide vane section

## 5. Conclusions

In this paper presented to simulate a multistage submersible pump flow and reduce observed inefficiencies.

- Simulation results indicated that there are recirculation regions in the flow passages of stationary parts which reduce the efficiency of the pump. It is considered that these recirculations are arisen from return channel blade geometry and several modifications were made to remove undesirable flow behaviour.
- It was expected that entrance shocks occur when the flow travels through stages in vaned areas. Therefore, blade angles were adjusted based on the flow angle at impeller exit to minimize losses.
- Additionally, when the flow with high kinetic energy encounters a sharp turn, flow separations are shown up. Blade geometry was designed in the manner that there should not be any rapid changes in blade curvature, so as to prevent recirculation occurrence.
- All these modifications considered, pump head at best efficiency point increased 14%, pump efficiency increased 12%, and loss coefficient decreased 50% for five stages of the pump.

## References

- [1] H.D. Nelson, J.M. Mc Vaugh, The dynamic rotor bearing system using finite elements, *J. Engg. Ind.* 98 (2) (1976) 593-600.
- [2] M. Tiwari, K. Gupta, O. Prakash. Dynamic response of an unbalanced rotor supported on ball bearings, *J. Sound. Vib.* 238 (5) (2000) 757-779.
- [3] Harish.S, Y.J. Suresh, Rotor Dynamic Analysis of a multi stage centrifugal pump, *Int. J. Innovative Research in Sci. Engg. and Tech* 3(9) (2014) 16055-16063.
- [4] Rounan Fan, Z. Liang, B. Fan. et.al., Numerical analysis of internal flow characteristics and energy consumption in assessment in full flow field of multistage centrifugal pump considering clearance flow, *Advances in Mech. Engg* 14(9) (2022) 1-16.

- [5] A.Alerci, E.Vagnoni, C.Nicolet et.al.,1D Numerical study of a multistage centrifugal pump during transient operation, IOP. Conf.series: Earth and Environmental science 1079 (2022)012103.
- [6] B.Sajjan, A.Santhosh, M.jayaram, K.Anusha, Linear static and Dynamic analysis of impeller type centrifugal pump with different materials,Int.j.Engg.Sci.and Computing 6(11) (2016) 3105-3116.
- [7] S.R Shah, S.V.Jain, R.N Patel,V J Lakhera, CFD for Centrifugal pumps: a review of the state –of-the-art, Procedia Engg 51(2013) 715-720.
- [8] Lijun L, Mingee He, Wensheng Ma et.al.,Dynamic characteristic analysis of the multi stage –centrifugal pump rotor system with uncertain sliding bearing structural applications, MDPI Machines 10,473, 2022.
- [9] F. Fontana, Performance analysis of compact multistage pumps manufactured from sheet metal, Proceedings of 12<sup>th</sup> European conference on Turbomachinery fluid dynamics & Thermodynamics ETC 12 (2017).
- [10] Hanamant T, M.S. Hebbal, Rotor Dynamic analysis of horizontal multistage centrifugal pump rotor, Int. Res.J. Engg. Tech.08 (08)2021 3795-3802
- [11] M. Isametova, et.al., Computer simulation and investigation vibration parametres of a centrifugal submersible pump, Kaunas Lithuania 2020.
- [12] Y.Dereli, Comparsion of rotodynamic coefiecients for labyrinth seals using a two control volume method, P I Mech .Eng. A-J PoW.222 (1) (2008) 123-135.

