



IOT BASED DETECTION OF ADULTERATION IN MILK

¹Kilari Jyothi, ²Vakacharla Vijaya Lalitha, ³Adari Hima Chandu,
⁴Pachakula Nookaraju, ⁵Satharu Malla Reddy

¹Associate Professor, Dept of ECE, Godavari Institute of Engineering and Technology(A), Rajahmundry, AP
^{2,3,4,5}Students, Dept of ECE, Godavari Institute of Engineering and Technology (A), Rajahmundry, AP

Abstract-The mammary glands of female mammals produce milk, a nutrient-dense liquid. It is an essential food source for young mammals, providing a balance of carbohydrates, proteins, fats, vitamins, and minerals necessary for growth and development. However, milk can also be consumed by humans, and it has been a staple food in many cultures around the world. Milk adulteration refers to the practice of adding or mixing different substances with milk to increase its quantity or improve its appearance, texture, or taste. In the present work, Arduino UNO Controller and sensors are used to develop a system for identifying and analyzing the adulterants in milk. This will help diaries and the general public to know the quality of milk and avoid various health risks.

Keywords: Milk adulteration, Arduino UNO micro controller, LCD screen, Sensors, Blynk application, diaries.

1. INTRODUCTION

Milk is a nutritious and broadly polished-off dairy item that has been a piece of the human eating regimen for millennia. It is an excellent source of the necessary nutrients for our body's growth and maintenance. Milk is a versatile food that can be consumed in various forms like whole milk, skimmed milk, condensed milk, etc. It is a primary ingredient in many dishes and beverages like tea, coffee, smoothies, and desserts. Milk is rich in macro nutrients like proteins, carbohydrates, and fats. It has two different types of proteins: whey and casein. Casein makes up around 80% of the protein content in milk and is responsible for its white color and thick texture. Whey makes up the remaining 20% and is a fast-digesting protein that helps in muscle growth and repair. Milk also contains lactose, a type of carbohydrate that provides energy to the body. Apart from macro nutrients, milk is also rich in micro nutrients like calcium, phosphorus, potassium, and vitamins like vitamins A, D, and B12. Calcium and phosphorus are essential for healthy bones and teeth, while potassium is required for maintaining fluid

balance in the body. Vitamin A helps in maintaining healthy eyesight, while vitamin D and B12 are required for the proper working of the nervous system. Milk also contains other beneficial components like probiotics, which are healthy bacteria that help in maintaining gut health.

There are many different kinds of milk on the market, like whole, skimmed, and flavored milk. Whole milk contains around 3.5% fat and is the most nutritious of all types of milk. Skimmed milk, on the other hand, contains no fat but has a higher amount of protein and carbohydrates. Flavored milk is a sweetened version of milk that is popular among children and adults.

Milk is a widely consumed food item across the globe. It consists of all of the necessary nutrients for the body's growth and development, it is regarded as a complete food. However, the adulteration of milk has become a serious issue in recent times. Adulteration is the process of putting harmful and cheap things in food to make it last longer and cost less. The adulteration of milk is a serious issue as it can have severe health consequences for consumers.

Milk adulteration can occur at various stages of production, right from the time the milk is collected from the cow to the point where it is delivered to the consumer. There are many types of milk adulteration that can occur, and each one can have its own set of health hazards. The most common types of milk adulteration are as follows:

1.1 TYPES OF ADULTERANTS ADDED TO THE MILK:

1. Addition of water: Water is added to milk to increase its quantity and make it more profitable for the milk suppliers. The addition of water to

milk can dilute its nutritional content and increase the risk of bacterial growth. Consuming adulterated milk can lead to digestive issues such as diarrhea, stomach cramps, and dehydration.

2. Addition of starch: Starch is added to milk to increase its thickness and consistency. This type of adulteration can be harmful as it can cause indigestion and lead to stomach disorders. Starch can also mask the presence of water in milk, making it difficult to detect.
3. Addition of synthetic milk: Synthetic milk is a mixture of chemicals and other substances that resemble milk in appearance and taste. It is commonly used to increase the quantity of milk and reduce its cost. Synthetic milk can contain harmful substances such as urea, detergent, and formalin, which can cause serious health problems such as kidney damage, liver damage, and cancer.
4. Addition of preservatives: Preservatives such as formalin, hydrogen peroxide, and urea are added to milk to increase its shelf life. These chemicals can cause serious health problems such as cancer, liver damage, and kidney damage.
5. Addition of animal fat: Animal fat such as tallow is added to milk to increase its fat content. High cholesterol and an increased risk of heart disease can result from this kind of adulteration.
6. Addition of antibiotics: Antibiotics are added to milk to prevent bacterial growth and increase its shelf life. However, consuming milk containing antibiotics can lead to antibiotic resistance, making it difficult to treat bacterial infections in the future.

In conclusion, milk adulteration is a serious issue that can have severe health consequences for consumers. It is essential to take preventive measures to ensure the purity and quality of milk.

2. LITERATURE SURVEY

With the help of sensors the values will be displayed on the LCD Display, the detection system can determine the milk's pH, NaCl, urea, and water content in less time.[1]

This whole milk analyzer framework is controlled by Arduino. Regulators are associated with various sensors. This method is simple to use. The Bluetooth module is used to transmit data in this.[2,7]

All the sensors are joined to frame a minimal and adaptable framework that breaks down and orders the nature of milk into various evaluations lastly yield is shown on the LCD screen & IoT platform.[3]

A milk parameter detection system based on an Arduino controller is demonstrated in this system. It is capable of reading the parameters and storing them in Mongo DB and blockchain DB. In order to combat issues such as milk adulteration with starch and urea during the assembly and processing of milk packets, the milk industry ought to be prepared to provide the government with real-time milk reading information with the assistance of IoT technology.[4,8]

The milk observing ID and testing framework utilizes pH, conductivity/impedance, and CO₂ sensors to anticipate bacterial development and milk diminishing. This suggested method uses a neural network classifier programmed into an Arduino UNO to quickly and inexpensively identify milk additives.[5,6]

3. METHODOLOGY

This proposed method uses sensors like Mq135, conductivity, temperature, and pH level to summarize the most essential and important studies in the field of contaminated milk. To determine the quality of milk,

these sensors are used. To determine the presence of microbes gas sensor is used. High-quality milk shouldn't be pungent, thus an Air Quality (MQ135) sensor is used to determine how pungent it is. A conductivity sensor is also used to determine how much water is in the milk.

It is a customized and precise test for milk contamination that is conducted using an Arduino UNO micro controller. The Blynk cloud server is then used to upload this data. This data is accessible to the user from anywhere in the world. A GSM module connected to this system transmits SMS messages to predefined mobile numbers.

We have created an effective system, as seen in Fig. 1, to identify milk adulteration in the proposed system. PH sensor, Air Quality Sensor, Temperature Sensor, Conductivity sensor, and Arduino UNO Controller are the main components of this system. The sensor values based on Milk Quality are shown using LCD module connected to the Arduino controller.

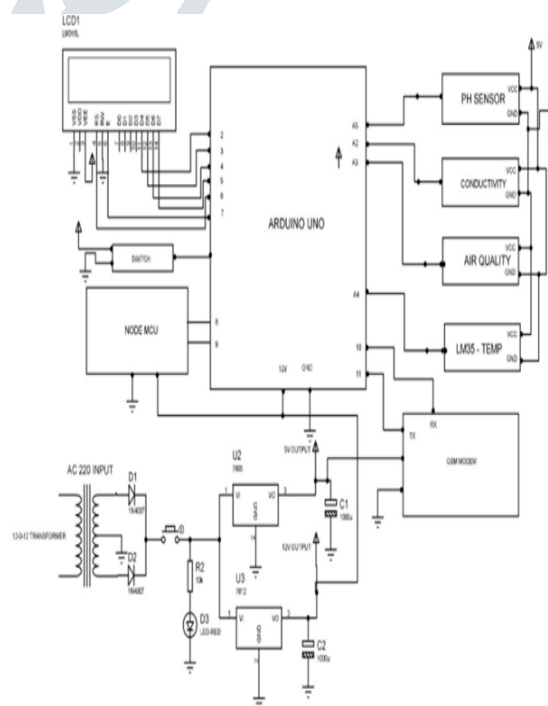

Fig 1. Circuit Diagram of the proposed system.

A sensor that measures air quality is used to assess milk's odour. The conductivity is checked with a conductivity sensor. Ph sensor determines the acidic or basic nature of milk. The temperature of the milk can be identified using a temperature sensor. This system has a GSM modem interface that allows the sensor values to be sent via SMS service to a predefined mobile number.

Moreover, IOT technology is integrated into this system to track real-time data on an IOT based cloud server. Everywhere in the world, users can follow this data using an Android app. A 12-0-12 Transformer serves as the project's main source. A bridge rectifier converts 12V AC to 12V DC. Voltage regulators and filter capacitors are used to produce regulated and continuous DC voltage.

4. RESULTS

A sample of approximately 100 ml of pure milk is taken in a glass with a pH range from 6.5-6.7, a temperature range of 20-40°C, and It will also possess a good smell. The pure milk sample is dipped into each of the sensors in the sensor unit, and the corresponding test is performed

Again, three impure milk samples are taken by adding different adulterants like detergent, water, and soap to the pure milk. For every sample the sensors are dipped in adulterated milk, the sensors will detect the changes and it will be displayed on the LCD screen and the Blynk application. The results of the sensors will be noted in Table 1.

Samples taken	PH	Air Quality	Temperature	Conductivity
Pure milk	6.5	444	35	545
Milk + soap	6.9	445	43	650
Milk+ water	6.7	440	30	740
Milk+detergent	6.9	732	45	700

Table 1. Showing the test results.



Fig 2. The values displayed on the Blynk application represent pure milk.



Fig 3. The values displayed on the Blynk application represent impure milk.

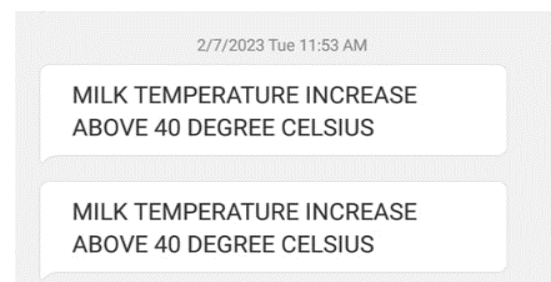

Fig 4. Message is sent to the predefined phone number where temperature crosses the threshold value.



Fig 5. Message is sent to the predefined phone number when gas crosses the threshold value.

5. CONCLUSION

The Arduino UNO micro controller is utilized to execute the proposed framework. This proposed system is a compact, adaptable framework that can evaluate milk quality and display the values on an LCD screen, and in the blynk application, this is made by combining all of the sensors. The problems faced by individuals and small dairies can be avoided by determining the quality of the milk and identifying milk that has been altered. This technology is cheap and easy to use.

6. FUTURE SCOPE

This project can be realized in the future in small and large milk dairies for cutting-edge milk analyzers. It is expected to execute IOT and DBMS for a charging framework, in which every client will have their own database, whereas the information is recorded for the amount of milk taken, and in which installment should be possible utilizing charge or Master card, and the installment should be possible on a monthly basis. Furthermore, the administration will use this framework to track milk production and advertising; all data from milk production to marketing will be saved on the executives' website, which can be accessed by any client with a record in that firm.

REFERENCES

1. Shrishti Nirwal, Rakesh Pan, and Nishant Rai, **2013**. "Analysis of milk quality, adulteration and mastitis in milk samples collected from different regions of Dehradun". *International Journal of Pharm Tech Research*, 5, pp.359–369.
2. Sumitra Goswami and Ashok Dangi," Arduino-Based Milk Quality Monitoring System", *International Journal of Agriculture, Environment, and Biotechnology(IJAEB)*: 14(2): 245-249, June 2021.
3. Ashwani Kumar, Gaurav Jaiswal, Mohit Kr. Nagar, Mr. Anuj Kumar," Embedded Based Milk Adulteration Detection & Live Monitoring Using Internet of Things (IoT)", *International Research Journal of Engineering and Technology (IRJET)*, e-ISSN: 2395-0056,2020.
4. Dr. S. MaryJoans, M. ThanigahaiVel, M. Mayilraj, M. Prithiviraj, S. Shriram "Adulteration detection in milk using the embedded system", *International Research Journal of Engineering and Technology (IRJET)* e-ISSN: 2395-0056,2020.
5. Dr. P. Ganesh Kumar, A.Alagammai, B.S.Madhumitha,B.Ishwariya,I'ot Based Milk Monitoring System for the Detection of Milk Adulteration", *ESP Journal of Engineering and Technology Advancements Volume 2 / Issue 2* Paper Id: JETA-V2I2P102 Page: 6-9.
6. Banupriya, Chaitanya R. Shetty, Supriya, and Varshitha, **2014**. "Comparison of different methods used for detection of urea in milk by quantification of ammonia". *IJARIEEE*, 3(3), pp.7858–7863.
7. Pradeep, S., lakshminarayana, P., Varsha, R. and Shriya, K. Kota, **2016**. "Screening of adulterants in Milk". *IJCRR*, 8(12), pp.25–29.

8. S. Huang, S. Ge, L. He, Q. Cai, and C. A. Grimes, "A Remote-Query Sensor For Predictive Indication Of Milk Spoilage," biosensors and bioelectronics, Vol. 23, no. 11, 2008, pp. 1745-1748.

