



Gearless Power Transmission

¹Gururaj M. Kumbar, ²Pandurang Morbale, ³Aniket Dhere, ⁴Santosh Niungare, ⁵Sumit Navale,

⁶Manjunath Magadam

¹Head of the Department, ^{2,3,4,5,6}UG Scholar,

^{1,2,3,4,5,6}Mechanical Engineering,

^{1,2,3,4,5,6}Dr. A. D. Shinde College of Engineering , Gadhinglaj, Maharashtra, India.

Abstract: The existing work by and large focuses on discovering an alternate alternative of tools drives for a number strength transmitting purposes in one-of-a-kind sectors. This mechanism is used as choice of bevel equipment for low price and low torque application. The effectivity of gears like bevel gear, spur equipment is much less due to collision and format is complicated as a end result it is costlier. The gearless elbow transmission is very low in cost as nicely an environment friendly and superb technique of up to 92% efficiency. This paper ambitions at a powerless transmission approach via the Elbow mechanism. Most elbow machines are constant role someplace (90 to a hundred and eighty degrees).

Today's world requires pace on every and each and every field. Hence rapidness and rapid working is the most important. Nowadays for reaching rapidness, a number of machines are manufactured through man. The engineer inconstantly conformed to the challenges of bringing thoughts and sketch in to reality. New machines and strategies are being developed always to manufacture more than a few merchandise at more cost-effective quotes and excessive quality. The mechanism "Gearless Power Transmission" is designed and manufactured for being compact, which is skillful and is having extra specific in transmitting energy at proper attitude besides any gears. The Working of this association is very easy & work efficiently with a very minimal quantity of electricity losses, which is skillful and is having some thing particular in transmitting electricity at proper attitude barring any gears being manufactured.

Index Terms – Gearless Transmission, Hub, Links Mechanism, Elbow Mechanism, Gearless.

I. INTRODUCTION

Today's world requires pace on every and each field. Hence rapidness and rapid working is the most important. Now a days for reaching rapidness, a number of machines and equipment's are manufactured via man. Engineer is continuously conformed to the challenges of bringing thoughts and diagram in to reality. New computing device and methods are being developed continually to manufacture more than a few merchandise at more cost effective prices and excessive quality. The assignment "GEARLESS TRANSMISSION" being compact and transportable equipment, which is skillful and is having some thing exercise in the transmitting energy at proper perspective besides any gears being manufactured. This venture offers us knowledge, experience, talent and new thoughts of the manufacturing. It is a working venture and having assurance of the success. El-bow mechanism is an ingenious hyperlink mechanism of slider and kinematic chain principle. This is additionally known as as "gearless transmission mechanism" this mechanism is very beneficial for transmitting action at proper angles. However in sure industrial utility "gearless transmission at proper angle" can also work at obtuse or correct attitude aircraft can be in contrast to worm and worm equipment or bevel and pinion tools which are continually used in the enterprise for severa application. The foremost function for mechanism comparatively excessive effectivity between the enter and the output electricity shafts with regards to the tools efficiencies. The El-bow Mechanism transmits the I/P strength toward the O/P aspect such away that the angular Forces produced in the slacks are clearly transmitted with the assist of pins which takes up the I/P strength and the proper perspective pressure is transferred closer to the O/P slack and pin assembly. Hence very little friction performs whilst the strength is being transmitted; the Hunting and returned lash are absent. Therefore, it is 1 Mechanical tasks : Learnmech.com favored that effectivity as excessive as 90-92% are viable in equipment much less transmission mechanism.

The first utility of this mechanism was once made use of the "Big Ben Clock" having 4 dials on the tower of London. This clock was once set up someday between 1630-1635 AD and nonetheless it is functioning in desirable condition.

II. DESIGN, MECHANISM

At the commencing supply short introduction about content material of the chapter. The fabric chosen for any thing must

- be without difficulty available
- be succesful of being processed in the preferred emanations and

- Have the imperative bodily properties. The gears commonly fail due to bending, fatigue and have an impact on and the gears are additionally accountable for the failure of the factors in the gears have to very cautiously decided because it may also lead to pitting.

III. FABRICATION

3.1 SHAFT

Shaft is difficult rotating computing device thing usually spherical in go sectional area, as pressure is applied, it is capable of transmitting electricity from one to every other part. The specific members, for e.g., gears and pulleys are installed on it. Material used in normal shafts is moderate steel, when excessive pleasant is needed.

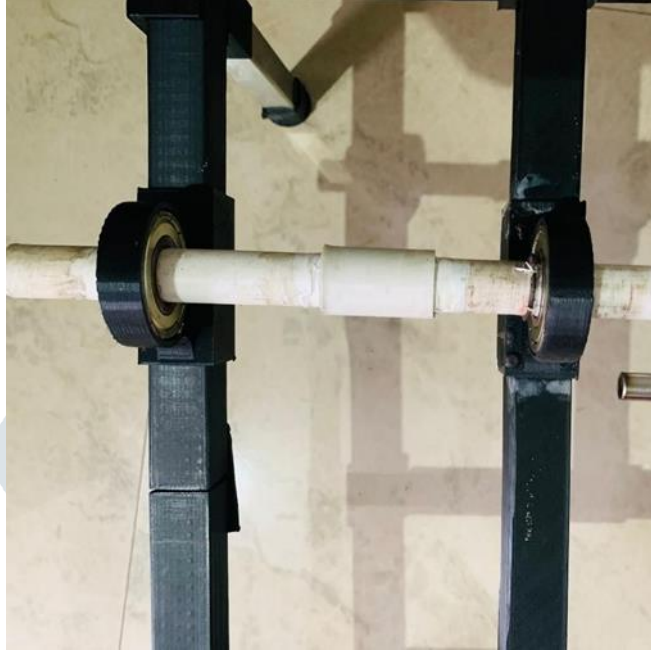

3.2 BALL AND ROLLER BEARING

ball bearings in that they are designed to lift a load whilst minimizing friction. It contains the shafts.



3.3 FRAME

Frame is the basis of these gearless transmission system. All mechanism of this assignment are installed on the frame.



3.4 HANDLE BEARING COVER

Handle bearing cowl offers help and maintains the bearing in consistent role Bearing is installed internal the bearing cover.



3.5 HUB

It have to be sturdy and minimal put on tear due to friction. It has three equidistant holes alongside it circumference which are used to incorporate the linkages of three steel rods as proven in figure. They are succesful of transmitting torque, axial forces, radial forces and bending moments. A hub is the central section of some thing such as a wheel, propeller, or fan, via which the axle passes. The axle passes via the hub of the wheel.



3.6 LINKING ROD

For electricity transmission we use the metal hole rods. The rods are welded by way of argon welding at ninety degree. A connecting rod with a anxiety load is made of solid steel, forged steel, or fabricated steel. Rods with a compression loading are forged nodular metal or aluminum alloy.



IV. METHODOLOGY

Firstly, we studied the lookup paper then studied mechanism after doing this we chosen the fabric and layout the parts. then we put together the mannequin these components in stable work and plan the 3D mannequin and subsequently we printed the components of mannequin one after the other the usage of 3D printer.

We manufacture this mannequin on 3D printer. Firstly, we learn about on this mechanism and working on it, and get statistics about it and make a 3D mannequin in stable work software. This mannequin of stable work is transformed in coding language and this code are grant to the printer and printer accomplished his work.

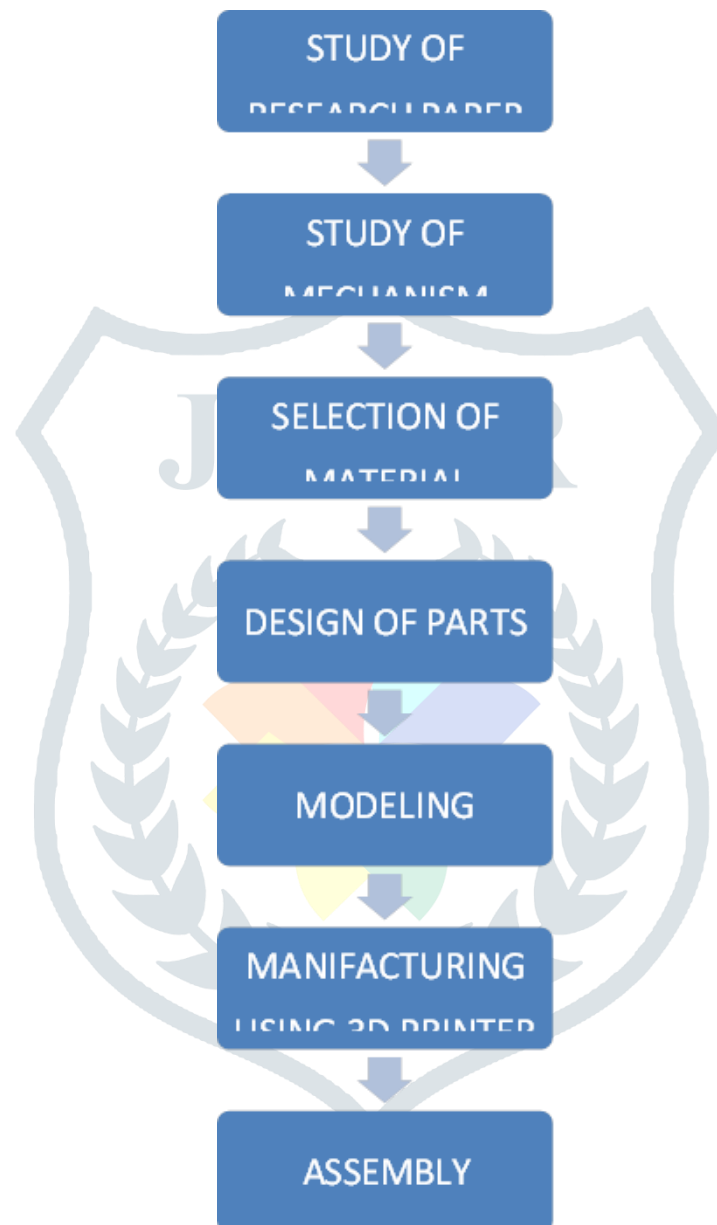

ASSEMBLY, WORKING AND TESTING

- Firstly, we print all components of this assignment in 3D printer.
- After the printing all components of this mechanism first off we have to bring together the base body and stands of this frame.
- Then we mount the ball bearing on this body with shaft and hub. and add clips to bearing to forestall slipping of the bearing from bearing casing.
- All components all want to be mount identical time due to the fact these are structured on every other.
- Main section of this to mount sliding hyperlinks in hub.
- The holes of hub are right on its role then it is easy.

3D Diagram of Gearless Power Transmission

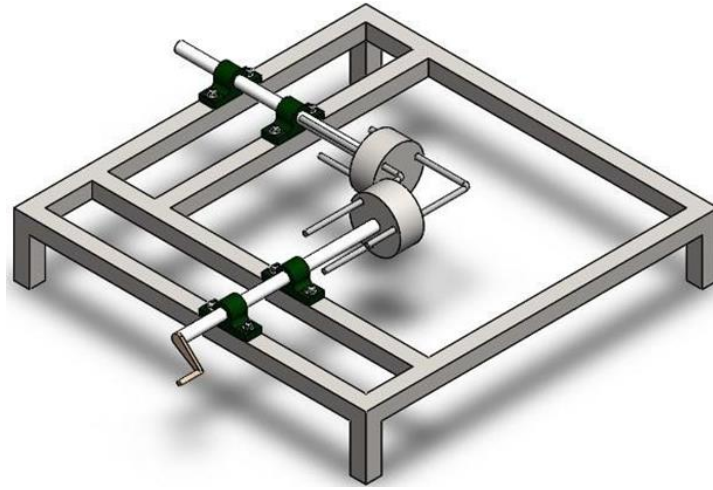

V. FUTURE SCOPE

Mainly In gearless transmission we use solely sliding pairs and Hub. The fabric used in manufacturing of sliding pair and hub ought to robust to put on and tear. But due to abrasive motion of dirt particles whilst working of hub and sliding pair reduces like noise is created whilst working ,and smoothness mechanism additionally decreases and there is a lot of energy loss whilst working. Due to these motives the accuracy of electricity transmission attitude additionally decreases. So as to limit such troubles and we delivered new issue in between hub and sliding pairs referred to as as Linear Motion Bearing.

Generally linear movement is used to decrease the friction and information the liner motion. When we used the linear action bearing in the Gearless transmission there is discount of put on and tear and noise is additionally decreased due to clean working. additionally it publications the hyperlinks to switch the energy at correct angle.

VI. CONCLUSION

This software has a vivid future for the enterprise due to its low cost. It can be used for mechanical operations such as drilling, drilling and grinding. This machine can be unexpectedly loaded due to the very subtle orientation of the elbow V-pins and harness. The impact of rust on this machine is much less than that of yaw drive. In this system, there is a slowdown due to the opposition for specificity between the harp and the elbow pin. It can be decreased through machining and lubricating the fabulous area. The ointment can be used in the well. However, the foremost blessings of this gadget are its versatility and low cost.

REFERENCES

- [1] U. Chakradhar , K. Muniteja , T. Charanteja , E. Lokesh, Ch. Tulasi Ram, T. Ajay , I. Karthik “A Review on Overview of Gearless Transmission Through Elbow Mechanism” Volume-2, Issue-11,
- [2] November-2019 ISSN (Online): 2581-5792
- [3] Rishikant Sahani, Rahul Chouhan, Prithvi RajSingh, Rahul Singh, Rahul Tiwari,” Designing and Fabrication of Gear less Power Transmission System” Vol. 5, Issue 04, 2017 | ISSN (online): 2321- 0613
- [4] Sarvaiya Rupen Ashkobhai “Gearless Transmission System” | Volume 4 | Issue 11 | May 2018 ISSN (online): 2349-784X
- [5] Praveen. R, Prabhu. L, Pranjal Khatri, Niranjn Kumar Mistry, Sahid Mondal “Design and Analysis of Gearless Drive System” ISSN: 2249 – 8958, Volume-8, Issue-6S3, September 2019
- [6] Piyush Ukey, Deepanshu Thoolkar, Nitesh Nagpure, Samrat Khobragade, Ankushkumar Yele, Gopal Gawande” Design and Development of Box Shifting Mechanism Using Gearless Power Transmission System” ISSN No: 2456-2156 Volume 6, Issue 6, June-2021
- [7] Neeraj Patil , Jayesh Gaikwad , Mayur Patil , Chandrakant Sonawane Shital Patel “Gearless Transmission Mechanism and its Applications” ISSN(Online) : 2319-8753 ISSN (Print) : 2347-6710
- [8] Sushan Gupta, Chankit Tiwary , Hemant Kumar , Ravi Teja Bodda Pati , Redagaani Uday Kiran and Jaspreet Singh “Design and fabrication of power transmission system through elbow mechanism” April 2021, Volume 8, Issue 4 (ISSN-2349-5162)
- [9] Md. Jewel Rana¹ and A. N. M Mizanur Rahman²,” Development and Performance Test of Gearless Power Transmission System” International Conference on Mechanical, Industrial and Energy Engineering 2018 23-24 , 2018, Khulna, BANGLADESH ICMIEE18-253 Jon Robert Pratt, “Vibration Control for Chatter Suppression with Application to Boring Bars”, Virginia Polytechnic Institute and State University, 1997
- [10]Praveen. R, Prabhu. L, Pranjal Khatri, Niranjn Kumar Mistry, Sahid Mondal “Design and Analysis of Gearless Drive System” ISSN: 2249 – 8958, Volume-8, Issue-6S3,
- [11]September 2019
- [12]Mahesh R. Kore, Sanket M. Adate, Siddhanath B. Honwar, Yogesh A. Chavan, Prof. A.A.Desai “Design and Fabrication of Gearless Power Transmission in Angular Position Using Rods: A Review” Journal of Recent Trends in Mechanics (e-ISSN: 2582-3213)