



Brain Tumor Recognition By Deep Learning Based On Modified Residual Network Approach

Adeeb Babu¹, Dr. Arvind Kourav², Prof. Nehul Mathur³,

¹M.Tech Scholar, ²Professor, ³Assistant Professor

^{1,2,3}Department of Electronics and Communication Engineering (ECE)

^{1,2,3}Bhopal Institute of Technology (BIT), RGPV, Bhopal, M.P. INDIA

Abstract : Brain tumors are one of the most prevalent and life-threatening conditions affecting individuals worldwide. Timely and accurate detection of brain tumor is critical for effective treatment and improved patient outcomes. This research work presents a comprehensive approach to brain tumor detection using advanced medical imaging techniques and machine learning algorithms. The power of medical imaging modalities such as magnetic resonance imaging (MRI) and computed tomography (CT) to obtain detailed structural and functional information about the brain. These imaging techniques provide crucial insights into the presence, location, size, and characteristics of brain tumor. Various image processing techniques are used in this application. In this research work, we use deep learning architectures such as CNN (Convolutional Neural Network), generally known as NN (Neural Network), and Res Net 50 model transfer learning to detect brain tumor. The performance of the model is predict whether a tumor is present or not in image. If the tumor is present, return yes; otherwise, return no. The proposed model shows better results than other methods in terms of accuracy, recall, and F1 score.

Keywords— Brain Tumor, Detection, Medical Imaging, Machine Learning, Deep Learning, Convolutional Neural Networks, MRI, CT, PET, Computer-Aided Diagnosis. Etc.

I. INTRODUCTION

The brain is the main component of the human neurological system. It is situated in the human head, and the skull protects it. All of the body's components are controlled by the human brain. It is a specific sort of organ that enables people to adapt to and tolerate any environmental conditions [1]. Humans can behave and communicate their thoughts and feelings thanks to their brains. In this section, we go through how the brain is organized to comprehend the most fundamental concepts. Fig.1: basic morphology of the human brain Primary brain tumor (benign tumor) and secondary brain tumor (malignant tumors) are the two basic categories into which brain tumors are divided. Gliomas are a form of brain tumor that is a benign tumor and develops slowly in the brain. It comes from atrocities, which are brain cells that are not neurons. Primary tumor are often less aggressive, but because of the strain they put on the brain, the brain becomes dysfunctional. The secondary tumor are more aggressive and spread into adjacent tissues more quickly [2]. Secondary brain tumor develop from other body parts. These tumors are caused by metastatic cancer cells that have travelled to various bodily parts, such as the brain and lungs. A secondary brain tumor is extremely cancerous. Lung, kidney, and bladder cancers are the primary causes of secondary brain tumor [3].

Classification of Brain Tumor

Here is a list of the majority of tumors that affect the brain or the structures that surround it. A tumor may occasionally go by several names. Since there are always exceptional instances (both better and worse), descriptions of how the tumors behave focus on the most prevalent patterns. In general, higher grade cancers are anticipated to progress more quickly than lower grade cancers [26]. The comments on tumor treatment usually refer to conventional therapy (surgery, radiation and cytotoxic chemotherapy) and may not include promising new, investigational or experimental treatments. For the majority of these tumors, radio surgical may be an option; however, whether it is used depends on the patient's specific circumstances, tumor location, and size. A second operation may be advised if a tumor grows despite therapy. This also depends on the individual patient. [13].

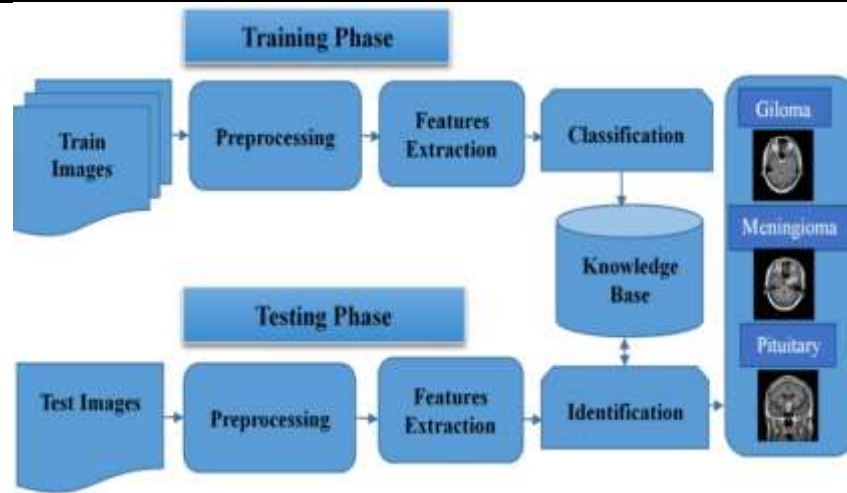

Fig 1 Classifications of Brain Tumor

II. LITERATURE SURVEY

M.O. Khairandish, et. al., (2022) This research work has applied a hybrid technique on brain MRI images to identify and categories the tumor utilizing the BRATS database. The system in place uses supervised hybrid CNN and SVM algorithms to categories brain pictures as benign or malignant tumors. The input pictures were first normalized using the main preprocessing processes, and then relevant features were extracted using the maximum stable extremely regions (MSER) approach and segmented using a threshold-based segmentation algorithm. To categories brain MRI images, labeled segmentation features are supplied as input to hybrid CNN and SVM algorithms. Overall, it achieved 98.4959% properly categorized the hybrid model, compared to 72.5536% for SVM alone and 97.4394% for CNN. The result showed the highest correctly classified with PPV and the lowest of FPV. A quick glance revealed that the hybrid model proposed offers improved and more efficient categorization procedures. Future research can demonstrate the overall improvement in decision-making using the quicker CNN with SVM and other optimization techniques (bioinspired algorithms) [01]. Vinayak Singh, et. al., (2022) This study focuses on objective function values (OFV) obtained by different CNN paradigms with the least validation cross-entropy loss (LVCEL), maximum validation accuracy (MVA), and training time (TT) in seconds. These values can be used as a workable tool by clinicians and the medical community to precisely identify tumor patients. A total of 2189 brain MRI images were used for the experimentation and assessment, and the best architecture had the greatest accuracy (0.8275), maximum objective function value (1.84), and area under the ROC (AUC-ROC) curve (0.737) for correctly identifying and categorizing whether or not a person was conscious [02]. Shko M. Qader, et. al., (2022) The primary goal of the DCNN-G-HHO described was to offer an automated brain tumor detection model. As a result, a CNN based on deep learning was taken into consideration and improved by using a hybrid optimization method that combines GWO and HHO approaches. Additionally, segmentation is crucial in the detection of tumors. As a result, an Otsu thresholding method is used. As a consequence, more accurate segmentation and classification were accomplished. On massive augmented MRI images, the performance of the new technique was evaluated by comparison with the old technique in terms of accuracy, precision, recall, f-measure, execution time, and memory consumption. The performance comparison initially showed that the proposed DCNN-G-HHO was significantly more effective than the existing methods. The suggested DCNN-G-HHO technique exceeded existing methods for brain tumor diagnosis, with 0.97 accuracy. This indicates the precision and efficacy of the method. The preceding approaches have lower recalls than the new strategy, which had a recall of 0.95. Finally, 0.96 is the Measure for the method described. Therefore, in terms of accuracy, precision, recall, and F-measure, the presented methodology is more effective than the current methods. [03]. P Gokila Brindha, et. al., (2021) one of the greatest methods for analyzing the picture collection is CNN. CNN performs the prediction by cropping the image to the desired size while preserving the necessary data. By giving more picture data, the testing accuracy of the ANN model created here, which is 65.21%, may be improved. Applying image augmentation techniques and examining ANN and CNN performance can achieve the same results. This model was created using the trial and error methodology. The amount of layers and filters that may be employed in a model will eventually be decided using optimization approaches. The CNN currently shows to be the best option for the supplied dataset [04]. Manav Sharma, et. al., (2021) The aim of this paper is to create a model with high accuracy to determine brain tumors from the MRI images. The dataset used consists of 253 brain MRI images and was sufficient to check the performance of the model. The model is based on the machine learning algorithm CNN (Convolutional Neural Network). It helps to predict just by reducing and resizing the image without losing any important information that will be used for predicting. The created model achieves an accuracy of 97.79% when applied to the training set and an accuracy of 82.86% when applied to the validation set. The loss gradually starts decreasing with the increase in the number of epochs. The model loss is very less when applied to the training set whereas it is high when applied to the validation set [05].

III. PROPOSED MODIFIED RESNET 50 MODEL

ResNet50 can be applied to the task of brain tumor detection using deep learning techniques. Here's a general overview of how ResNet50 can be utilized in the context of brain tumor detection:

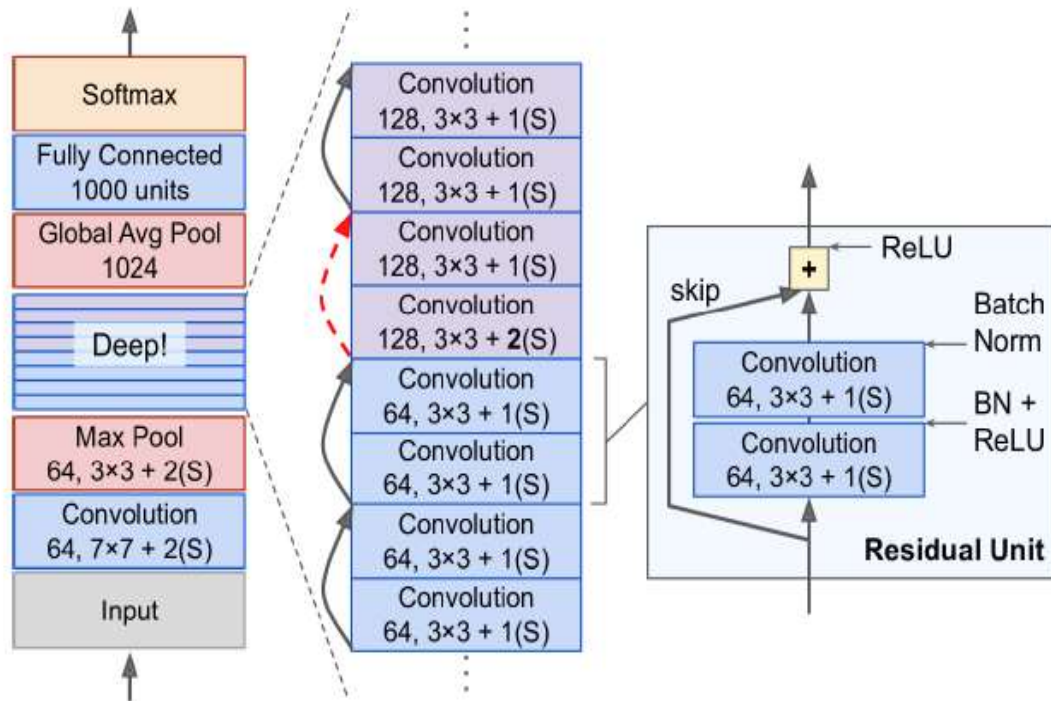

Fig. 2: Shows the proposed model of proposed RESNET 50 model

Proposed Method

In the below section discuss the different steps there are used in the training and testing of proposed method. The complete proposed method will divide in the three section in Initialization (Pre-processing), training and testing validation. For the implementation of proposed method required two major library keras library and tensor flow.

Steps - Initialization (Pre-processing)

Step 1: First connect the derive and call the data set for training.

Step 2 : Second install live loss plot from live loss plot. keras library.

Step 3: Third step import keras library, and import Resnet 50 in tensor flow.

Step 4: Import tensor flow model

Step 5: Import Adam optimizer and SGD.

Step 6: Set the input image size that is 224x224, Set the batch Size of data that is 32. So the total image size of the image is (224,224, 32)

Step 7: In the next step create the base pre-trained model for VGG16 that in resnet50.

Step 8: Now applying average pooling layer in the model, for this first apply flatten layer, then apply dense layer with activation function 'relu' then apply dropout layer.

Training Phase

Step 9: Apply dense layer with activation layer of soft-max. Now model is ready for training.

model = Model(inputs=conv_base.input, outputs=predictions)

IV. Result Discussion And Analysis

In this discuss the result analysis and discussion of proposed method that is based on **modified ResNet 50 model** that is discussed in the previous chapter. Through our research, we've learned that python is a popular tool for carrying out the techniques we propose. While conducting our proposed experiments, we make use of the well recognised tumor data set. Early detection and classification of brain tumors is an important research domain in the field of medical imaging and accordingly helps in selecting the most convenient treatment method to save patients life. The application of deep learning approaches in context to improve health diagnosis is providing impactful solutions. According to the World Health Organization (WHO), proper brain tumor diagnosis involves detection, brain tumor location identification, and classification of the tumor on the basis of malignancy, grade, and type.

This experimental work in the diagnosis of brain tumors using Magnetic Resonance Imaging (MRI) involves detecting the tumor, classifying the tumor in terms of grade, type, and identification of tumor location. This method has experimented in terms of utilizing one model for classifying brain MRI on different classification tasks rather than an individual model for each classification task. This dataset is a combination of the following three datasets: Figshare Dataset ,Sartaj Dataset and Br35H Dataset.

This dataset contains 7023 images of human brain MRI images which are classified into 4 classes: Glioma-meningioma - No tumor and Pituitary. No tumor class images were taken from the Br35H dataset. SARTAJ dataset has a problem that the glioma class images are not categorized correctly, this from the results of other people's work as well as the different models trained. A set that will be used in the implementations; and the third provides an inventory of the tables, snapshots, and graphs that will be important to the success of the proposed task.

Result Parameters

To measure the efficacy of an N-class target class classification model, the N-by-N Confusion Matrix is used. The predictions of the machine learning model are compared in a matrix with the actual target values. Expected values for the dependent variable are shown in the columns. In this section discuss the different result parameters outcomes of different proposed training methods.

Table I: Training and Validation Loss

Training	(min: 0.041, max: 0.947, cur: 0.043)
Validation	(min: 0.237, max: 0.636, cur: 0.301)

159/159 [=====] - 109s 685ms/step - loss: 0.0434 - validation loss: 0.3006.

In the below fig. 3 shows the validation curve of proposed model. In the x axis represent the number of epoch of the proposed model that is in between 0 to 25 in the Y axis shows the error in terms of mean square error .

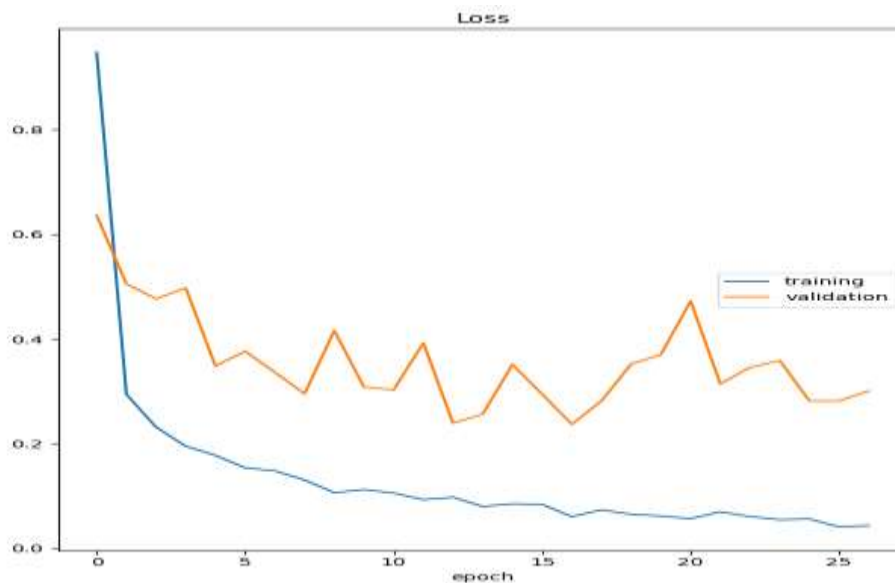

Fig. 3 Shows the training and validation of proposed ResNet 50 deep learning model

Now discuss the result parameters in terms of true positive true negative false positive false negative in the confusion matrix. In the below fig. 4 shows the outcomes in terms confusion matrix that is made by TP,TN,FP and FN. In the proposed method there are four classes are classified. On the basis of proposed method shows accuracy up to 95.34%. In the next table II shows the other result parameters that is based on confusion matrix. These parameters are Accuracy score, Precision score, Recall score, F1 Score and Cohen Kappa Score.

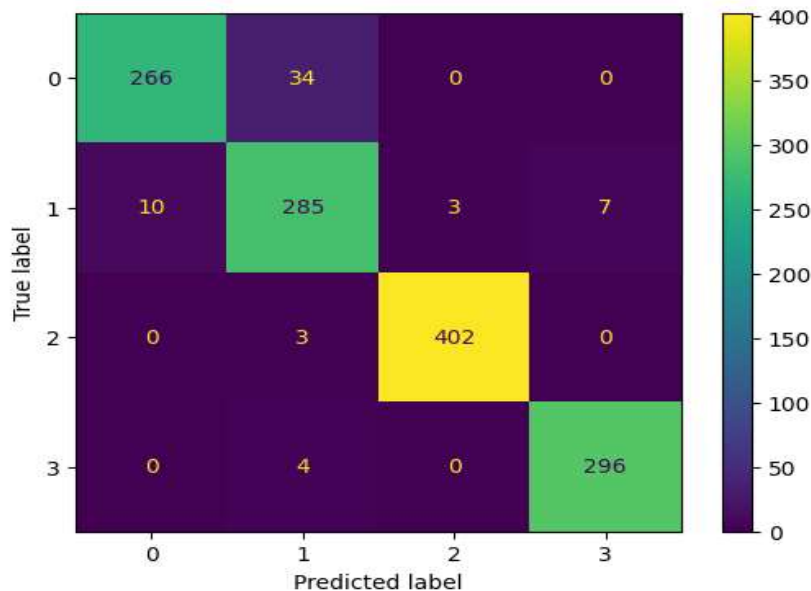

Fig. 4 Shows the confusion Matrix of proposed method outcomes

ResNet Model Accuracy with Fine-Tuning: 95.34%

Table II: Experimental Result Outcome

Result Parameters	Outcomes
Accuracy score	0.9534
Precision score	0.9548
Recall score	0.9534
F1 Score	0.9535
Cohen Kappa Score	0.9375

V. CONCLUSION

Deep learning has proven to be a valuable tool in the field of brain tumor detection. By leveraging deep neural networks and advanced image processing techniques, researchers and medical professionals have developed accurate and efficient methods for detecting and classifying brain tumors from medical imaging data. The Convolutional Neural Network (CNN) based classification is equipped for the classification and detection of tumors. The identification of brain tumor location is also done using a CNN-based model by segmenting the brain tumor is presented in research work. The proposed model is based on modified ResNet 50. ResNet 50 model shows better accuracy and other result parameters as compare to other deep learning model such CNN as well as VGG 16 model. The use of deep learning in brain tumor detection has several benefits. It enables automated and objective analysis of medical images, reducing human error and variability. Deep learning models can process large amounts of data quickly, allowing for faster and more efficient diagnoses. They can also handle complex features and patterns in the images, leading to improved accuracy in tumor detection.

REFERENCES

- [1] Khairandish, Mohammad Omid, Meenakshi Sharma, Vishal Jain, Jyotir Moy Chatterjee, and N. Z. Jhanjhi. "A hybrid CNN-SVM threshold segmentation approach for tumor detection and classification of MRI brain images." *Irbm* 43, no. 4 (2022): 290-299.
- [2] Singh, Vinayak, Mahendra Kumar Gourisaria, Harshvardhan GM, Siddharth Swarup Rautaray, Manjusha Pandey, Manoj Sahni, Ernesto Leon-Castro, and Luis F. Espinoza-Audelo. "Diagnosis of intracranial tumors via the selective cnn data modeling technique." *Applied Sciences* 12, no. 6 (2022): 2900.
- [3] Qader, Shko M., Bryar A. Hassan, and Tarik A. Rashid. "An improved deep convolutional neural network by using hybrid optimization algorithms to detect and classify brain tumor using augmented MRI images." *Multimedia Tools and Applications* (2022): 1-28.
- [4] Brindha, P. Gokila, M. Kavinraj, P. Manivasakam, and P. Prasanth. "Brain tumor detection from MRI images using deep learning techniques." In *IOP conference series: materials science and engineering*, vol. 1055, no. 1, p. 012115. IOP Publishing, 2021.
- [5] Sharma, Manav, Pramanshu Sharma, Ritik Mittal, and Kamakshi Gupta. "Brain tumour detection using machine learning." *Journal of Electronics* 3, no. 4 (2021): 298-308.
- [6] Woźniak, Marcin, Jakub Siłka, and Michał Wiecek. "Deep neural network correlation learning mechanism for CT brain tumor detection." *Neural Computing and Applications* (2021): 1-16.
- [7] Yaqub, Muhammad, Jinchao Feng, M. Sultan Zia, Kaleem Arshid, Kebin Jia, Zaka Ur Rehman, and Atif Mehmood. "State-of-the-art CNN optimizer for brain tumor segmentation in magnetic resonance images." *Brain Sciences* 10, no. 7 (2020): 427.
- [8] Roy, Sanjiban Sekhar, Nishant Rodrigues, and Yh Taguchi. "Incremental dilations using CNN for brain tumor classification." *Applied Sciences* 10, no. 14 (2020): 4915.
- [9] Sajjad, Muhammad, Salman Khan, Khan Muhammad, Wanqing Wu, Amin Ullah, and Sung Wook Baik. "Multi-grade brain tumor classification using deep CNN with extensive data augmentation." *Journal of computational science* 30 (2019): 174-182.
- [10] Amin, Javaria, Muhammad Sharif, Mudassar Raza, Tanzila Saba, and Muhammad Almas Anjum. "Brain tumor detection using statistical and machine learning method." *Computer methods and programs in biomedicine* 177 (2019): 69-79.
- [11] Kaldera, H. N. T. K., Shanaka Ramesh Gunasekara, and Maheshi B. Dissanayake. "Brain tumor classification and segmentation using faster R-CNN." In *2019 Advances in Science and Engineering Technology International Conferences (ASET)*, pp. 1-6. IEEE, 2019.
- [12] Khan, Muhammad A., Ikram U. Lali, Amjad Rehman, Mubashar Ishaq, Muhammad Sharif, Tanzila Saba, Saliha Zahoor, and Tallha Akram. "Brain tumor detection and classification: A framework of marker-based watershed algorithm and multilevel priority features selection." *Microscopy research and technique* 82, no. 6 (2019): 909-922.
- [13] Özyurt, Fatih, Eser Sert, Engin Avci, and Esin Dogantekin. "Brain tumor detection based on Convolutional Neural Network with neutrosophic expert maximum fuzzy sure entropy." *Measurement* 147 (2019): 106830.
- [14] Myronenko, A. (2019). 3D MRI brain tumor segmentation using autoencoder regularization. In *Brainlesion: Glioma, Multiple Sclerosis, Stroke and Traumatic Brain Injuries: 4th International Workshop, BrainLes 2018, Held in Conjunction with MICCAI 2018, Granada, Spain, September 16, 2018, Revised Selected Papers, Part II 4* (pp. 311-320). Springer International Publishing.
- [15] Chandra, Saroj Kumar, and Manish Kumar Bajpai. "Effective algorithm for benign brain tumor detection using fractional calculus." In *TENCON 2018-2018 IEEE Region 10 Conference*, pp. 2408-2413. IEEE, 2018.

- [16] Rashid, M. H. O., M. A. Mamun, M. A. Hossain, and M. P. Uddin. "Brain tumor detection using anisotropic filtering, SVM classifier and morphological operation from MR images." In *2018 international conference on computer, communication, chemical, material and electronic engineering (IC4ME2)*, pp. 1-4. IEEE, 2018.
- [17] Bahadure, Nilesh Bhaskarrao, Arun Kumar Ray, and Har Pal Thethi. "Image analysis for MRI based brain tumor detection and feature extraction using biologically inspired BWT and SVM." *International journal of biomedical imaging 2017* (2017).
- [18] ShanmugaPriya, S., and A. Valarmathi. "Efficient fuzzy c-means based multilevel image segmentation for brain tumor detection in MR images." *Design Automation for Embedded Systems 22* (2018): 81-93.
- [19] Rao, C. Hemasundara, P. V. Naganjaneyulu, and K. Satya Prasad. "Brain tumor detection and segmentation using conditional random field." In *2017 IEEE 7th International Advance Computing Conference (IACC)*, pp. 807-810. IEEE, 2017.
- [20] Dong, Hao, Guang Yang, Fangde Liu, Yuanhan Mo, and Yike Guo. "Automatic brain tumor detection and segmentation using U-Net based fully convolutional networks." In *Medical Image Understanding and Analysis: 21st Annual Conference, MIUA 2017, Edinburgh, UK, July 11–13, 2017, Proceedings 21*, pp. 506-517. Springer International Publishing, 2017.
- [21] Haritha, D. "Comparative study on brain tumor detection techniques." In *2016 International Conference on Signal Processing, Communication, Power and Embedded System (SCOPEs)*, pp. 1387-1392. IEEE, 2016.
- [22] Somwanshi, Devendra, Ashutosh Kumar, Pratima Sharma, and Deepika Joshi. "An efficient brain tumor detection from MRI images using entropy measures." In *2016 international conference on recent advances and Innovations in engineering (ICRAIE)*, pp. 1-5. IEEE, 2016.

