



# Underwater Tank Cleaning Robot for Domestic and Industrial Tank

<sup>1</sup>Prof. Devendra Holey, <sup>2</sup>Smita Lakhade, <sup>3</sup>Divya Sahare, <sup>4</sup>Utkarsha Warghane, <sup>5</sup>Muskan Satramwar

<sup>1,2,3,4,5</sup>Department Of Electrical Engineering, KDK College of Engineering, Nandanwan, Nagpur, Maharashtra, India

## Abstract:

The concept, "Underwater Tank Cleaning System," presents a novel method for effectively clearing debris from underwater tank. Utilizing a PMDC motor as its main power source, the system integrates a diaphragm water pump and filtration bag to efficiently eliminate contaminants. The inclusion of a suction pipe enables thorough debris intake, ensuring comprehensive cleaning. To guarantee safe and enduring operation, a thermistor is integrated to oversee and regulate motor temperature underwater. Enhancing user engagement and control, the system incorporates a Cam Development Board (ESP32), allowing real-time monitoring and control of the cleaning process through a wired connection. Additionally, SMPS and motor controlling switching are employed to efficiently distribute power among the left motor, right motor, and water pump. Algae removal is facilitated by brushes, while a buck converter is linked with the cam board for optimized functionality. This holistic design guarantees effective, user-friendly, and dependable underwater tank cleaning.

**Keywords-** PMDC Motor, Flow Meter, filtration Bag, SMPS.

## I. INTRODUCTION

In water storage facilities, the maintenance of water quality involves the cleaning of floor and walls of water tank that stores the water [1]. Maintaining underwater tank, whether used industrially, agriculturally, or recreationally, presents unique challenges due to the accumulation of debris and contaminants. Water is frequently tested each day, and if the chlorine levels decrease, operators simply add more chlorine without investigating the cause. Over time, this excess chlorine breaks down and can become a contaminant in the tank, potentially leading to health risks such as cancer [2]. Rather than relying on continuous chemical treatment, the removal of sediment from the tank floor offers a more effective solution. Traditional cleaning methods are often laborious and time-intensive, demanding manual effort and significant resources. In response, the "Underwater Tank Cleaning System" offers a pioneering approach by harnessing modern technology and engineering concepts. ROVs designed for cleaning domestic and industrial tanks have been developed both internationally and in India, although not as extensively as ROVs for tank inspection. Various reservoir structures and water management techniques are employed by corporations and water utilities, leading to the need for specialized ROVs tailored to specific types, sizes, and conditions of reservoirs. In India, for instance, Gridbots has

Developed a robot called SaUsR for this purpose [1]. This paper introduces a comprehensive system meticulously designed to clean debris from underwater tank surfaces efficiently. At its core, the system utilizes a PMDC motor as the primary driving force for cleaning operations. Complementing the motor are a diaphragm water pump and a specialized porous bag engineered to effectively eliminate contaminants. Incorporating a suction pipe facilitates seamless debris intake, ensuring thorough cleaning while minimizing disruption. Prioritizing operational safety and equipment longevity, the system integrates a thermistor to monitor and regulate motor temperature underwater. This proactive measure mitigates overheating risks and potential damage, thereby enhancing the system's reliability and lifespan. Additionally, the system is equipped with a Cam Development Board (ESP32). This functionality enables users to oversee and manage the cleaning process via a wired connection, offering valuable feedback and control options.

## II. METHODOLOGY

It would use suction pipe to suck various types of debris that are found in underwater tank including algae, mold, rust, sediment, sand, organic matter, and sometimes even rocks. These materials may need to periodically remove to maintain the tank's efficiency and prevent clogging or contamination issues.

It would use PMDC motor serves the purpose of driving the cleaning mechanism, suction devices, to remove dirt from tank's surface. The PMDC motor provides the necessary power and torque to operate the cleaning equipment efficiently underwater (compact size, high efficiency, precise speed control).

The key components would include a dc motor, an intake hose or nozzle, and filtration bag to capture particles. The motor creates a pressure difference that causes air to be drawn in, carrying debris with it into the collection tank.

The filtration bag is used to capture the debris that are found in tank's surface. It will also capture large debris such as stones, leaves, twigs, that may have fallen into tank, or other sizable particles from entering the potentially clogging the cleaning equipment or the plumbing system.

### III. FILTRATION PROCESS AND CONTROL MECHANISM

The water suction and filtration process is shown in fig.1, for which it uses water suction element from which it will take in the water and the debris of tank's surface that will go through primary porous element. An 800 LPH high flow suction pump will create pressure difference causes air to be drawn in carrying debris with it into the secondary filter element and the water flow sensor will sense water flow after that clear water will be come out.

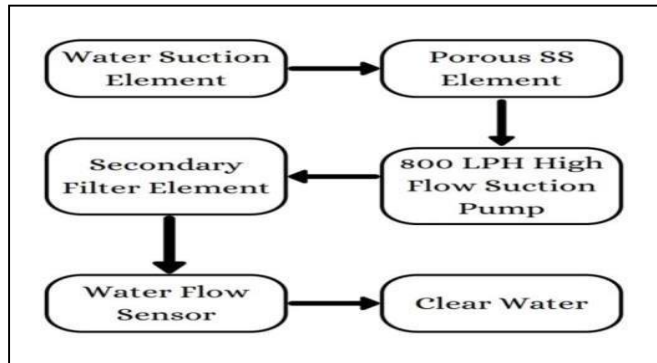

Fig.1. Water Suction and Filtration Process

The controlling mechanism is shown in fig.2, it uses arduino microcontroller displayed by 16\*2 LCD display, and it takes input from robot control switches, filter switches, and water flow sensor and gives output to relay, relay driver and buzzer. As arduino and camera module works on 5 V DC, it uses SMPS that convert 230 V AC to 12 V DC, and gives input to buck converter that convert 12 V DC to 5 V DC. The relay and relay driver gives output to 230 V AC water pump, left motor and right motor to drive the wheels of the system.

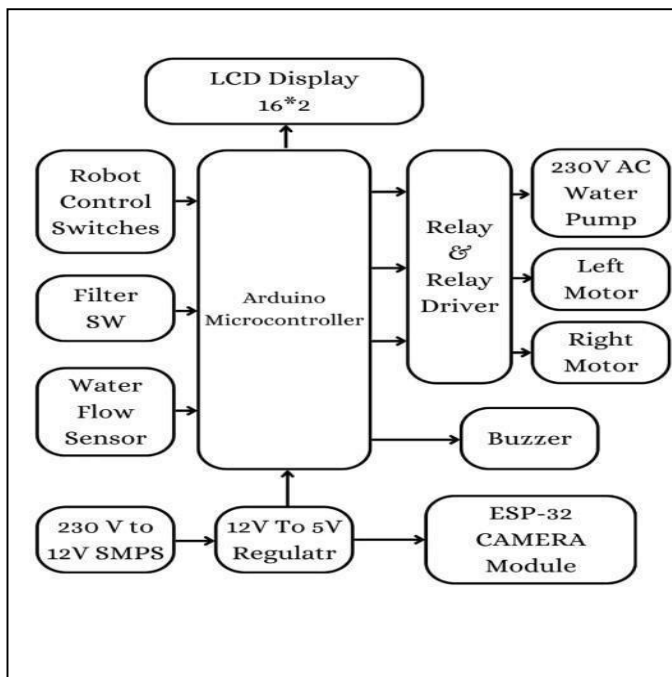

Fig.2. Controlling Mechanism

Fig.3 shows the image of water flow sensor that the system uses to sense the water flow. Flow meters measure the rate at which water or cleaning solution is flowing through the system. This ensures that the right amount of fluid is being circulated, preventing wastage and ensuring that the cleaning process.



Fig.3. Flow Meter

Fig.4 shows the image of motor used to suck water from tank. This motor typically provides enough power to drive the pump or agitator needed to circulate water or cleaning solution within the tank.



Fig.4. Motor

Fig.5 shows the image of porous bag that works as garbage bag in the system. Filtration bag are designed to remove debris, sediment, and other particles from water used in systems to prevent clogging of nozzles, and other equipment.



Fig.5. Filtration Bag

For the filtration system following components are used which is mentioned in table 1

Table 1 Components used in prototype

Sr. no.	Components
1	Brushes
2	Suction Pipe
3	SMPS
4	Motor Controlling Switches
5	Diaphragm Water Pump
6	Porous bag
7	Wheels
8	PMDC Motor
9	Thermistor (To protect motor from heat underwater)
10	Buck Converter
11	Cam Development Board

#### IV. ADVANTAGES OF FILTRATION ROBOT

**Efficient Cleaning:** The primary goal of the system would be to efficiently clean the interior surfaces of the tank, removing debris, sediment, algae, or other particles.

**Improved Water Quality:** Cleaning should lead to improved water quality within the tank, ensuring that it meets required standards for its intended use, whether it's for drinking water, industrial processes, or other purposes.

**Cost Savings:** By reducing the frequency of manual cleaning or the need for expensive specialized equipment, a good cleaning system should provide cost savings over time.

**Safety:** The system should prioritize safety for both personnel and the environment. This includes minimizing risks associated with entering the tank for cleaning purposes and ensuring that cleaning agents used are safe and environmentally friendly.

**Automation and Control:** Ideally, the system should offer automation and control features to streamline the cleaning process, allowing operators to monitor and adjust cleaning parameters as needed.

**Longevity of Infrastructure:** Regular cleaning helps extend the lifespan of the tank and associated infrastructure by preventing corrosion, degradation, or other damage caused by accumulated debris and contaminants.

#### V. CONCLUSION

In conclusion, the development of an underwater tank cleaning system offers numerous benefits, including efficient cleaning, improve the water quality, also it save the cost, it ensures the safety and provide longevity of infrastructure. The system provides great automation feature. By utilizing advanced technology and innovative design, this system addresses the challenges associated with traditional tank cleaning methods. Its ability to operate in underwater environments makes it a valuable asset across various industries. With further refinement and implementation, this system holds great potential for revolutionizing underwater maintenance practices and promoting environmental sustainability.

#### REFERENCES

- [1] Munjik, L., Jeong, W., Park, S. H., Park, J. W., Lee, S. K, Park, J. G., Kim, Y. J. 2012. An Underwater Cleaning Robot for Industrial Reservoirs. Proceedings of the IEEE Conference on Automation Science and Engineering (CASE).
- [2] EPA Office of Water, Health Risk from Microbiological Growth and Biofilms in Drinking water Systems, June 17, 2002.