



Forest fire detection system Based on IOT

Dhammadip Mendhe ¹, Mayur Padole², Mohit Jodhe ³, Swaraj Badole⁴, Rafe Iqbal⁵
Prof.Umesh Samarth⁶

U.G. Student, Department of Information Technology Engineering, JD Engineering College, Fetri Nagpur, Maharashtra, India^{1,2,3,4}

Ass Prof, Department of Information Technology Engineering, JD Engineering College, Fetri Nagpur, Maharashtra, India⁶

ABSTRACT:

A forest fire detection system leveraging the capabilities of the Internet of Things (IoT) has emerged as a crucial innovation in modern forest management and wildfire prevention. This system is designed to proactively monitor and detect potential fire outbreaks in real-time by deploying a network of interconnected sensor nodes across forested areas. These nodes collect data on environmental variables such as temperature, humidity, and gas concentrations. Through a wireless communication network, these data are transmitted to a central control station for comprehensive analysis.

The heart of the system lies in its sophisticated data processing algorithms that examine the incoming data for anomalies and patterns associated with fire ignition. By applying localized analysis at individual sensor nodes and centralized analysis at the control station, the system effectively filters out false alarms while accurately identifying conditions indicative of a developing fire. Upon detecting such conditions, the system generates instant alerts and notifications to authorised stakeholders, including forest rangers, firefighting teams, and relevant authorities.

The advantages of this IoT-based forest fire detection system are substantial. Its early detection capabilities empower rapid response, minimising the potential extent of wildfires and their associated ecological and economic damage. Furthermore, the system's remote monitoring

features enable real-time observation of forest conditions, while the collection of environmental

data contributes to ongoing research efforts. The system's integration into existing emergency response infrastructure enhances coordination among various teams and stakeholders.

However, challenges remain in achieving optimal system performance. Ensuring energy efficiency for sensor nodes, maintaining data security, and establishing a reliable communication network are critical factors. Environmental variables and physical obstacles can impact sensor accuracy, warranting careful deployment considerations. The successful implementation of this system requires meticulous design, robust technology, and effective alignment with established emergency management protocols.

In conclusion, the IoT-based forest fire detection system stands as a groundbreaking solution to enhance forest fire prevention and management. Through its ability to provide early warnings and facilitate swift responses, it has the potential to substantially mitigate the devastating effects of wildfires on natural ecosystems and human communities.

KEYWORDS:

forest fire detection, Internet of Things (IoT) Sensor nodes, Environmental Monitoring, Early Warning system, Wireless communication Central control station, Real-time alerts Wildfire prevention, Remote monitoring, Sensor network

INTRODUCTION

The increasing frequency and intensity of forest fires pose significant challenges to ecosystems, communities, and economies worldwide. Timely detection and swift response are critical to mitigate the devastating effects of these fires. Leveraging the capabilities of the Internet of Things (IoT), a novel approach to forest fire detection has emerged, offering the potential to revolutionise wildfire management. This system combines advanced sensor technology, wireless communication, and data analysis

algorithms to create a proactive and responsive solution for early fire detection and mitigation.

The IoT-based forest fire detection system represents a paradigm shift in the way we monitor and address the threat of wildfires. Traditional methods, while effective to some extent, often fall short in providing real-time data and timely alerts necessary for proactive intervention. In contrast, the integration of IoT technologies offers a dynamic and data-driven approach that enhances accuracy, efficiency, and coordination in the fight against forest fires.

This paper delves into the intricacies of the IoT-based forest fire detection system, exploring its components, functioning, advantages, challenges, and potential impact. By fusing cutting-edge sensor capabilities with intelligent data analysis and rapid communication networks, this system holds the promise of not only improving early detection but also reshaping the landscape of forest fire management. Through a comprehensive examination of its mechanisms and implications, we uncover the transformative potential of this innovation in safeguarding our natural landscapes and communities from the escalating threat of wildfires.

II. LITERATURE SURVEY

Numerous answers for identification of out of control fire are displayed and executed in recent years. Video Surveillance System is most generated into four classifications : Video Cameras delicate in unmistakable range in light of acknowledgment of smoke amid sunlight and fire blazes at night, Infrared(IR) Thermal Imaging cameras in view of discovery of warmth transition from the fire, IR Spectrometer which distinguish unearthly attributes of smoke gases and Light Detection and Ranging (LIDAR) system which measures the laser light back scattered by smoke particles. The limitation of these systems was high false alert rate as a result of climatic conditions, for instance, proximity of fog, shadows, clean particles etc. Another strategy is the utilization of Visual Cameras that take depictions of the forest to identify the fire. These cameras were mounted on the highest point of correspondence towers. A turning engine is introduced to give a full round perspective of the forest. The pictures got from the camera are prepared utilising project code and are contrasted and the reference pictures taken at introductory stage. This framework additionally had impediment of high false caution rate. Additionally the cost of establishment of visual cameras on correspondence towers was high Another technique is the utilisation of satellite framework to distinguish the wild fire.

The primary segments of the framework are satellite(s) and the base station that gathers the information send by the satellite(s) and runs the dissecting calculation. The crude information from the satellite(s) is handled and after that Best in class High Determination Radiometer (AVHRR) instrument usually utilised for identification of wild fire. It is utilized to recognize nearness of Problem areas.

However the mists enormously influence the framework Wild Fire Reconnaissance Framework which comprises WSN was likewise proposed for identification of wildfires in South Korea. The WSN decides the temperature and dampness after which middleware program and web application examines the gathered information .However in this approach of discovery of wild fire there was some loss of information amid correspondence WSN comprising three various types of sensors which can distinguish temperature, fire and smoke levels of methane, carbon monoxide and carbon dioxide was additionally proposed for wildfire recognition .The information gained by sensors is transmitted utilizing radio recurrence modules. The radio recurrence module used has limited bandwidth and also picks up noise easily WSN consisting of temperature sensor setup and GPS module was likewise proposed for recognition of backwoods fire .In this temperature information was transmitted to base station through essential and principle receiving wire utilising satellite. A portion of the impediment of framework was establishment of an excessive number of reception apparatuses; consistent power was required to both temperature sensor setup and receiving wires. Notwithstanding this climatic/regular changes can influence the framework .

III. METHODOLOGY

BLOCK DIAGRAM

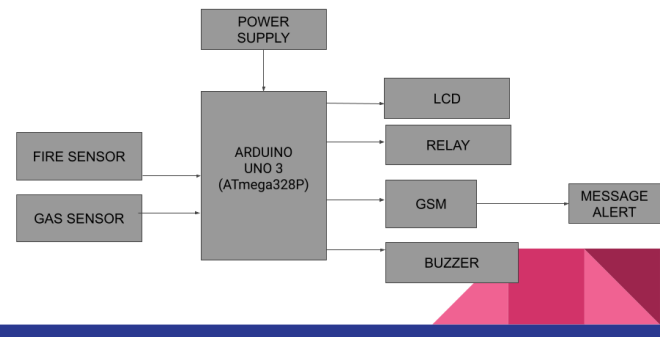

Fig 1:-flow chart

The methodology of the IoT-based forest fire detection system presents a comprehensive and structured approach to address the critical challenge of timely wildfire detection and response. This methodology encompasses various key phases. First, sensor nodes are strategically placed across forested areas to capture vital environmental data such as temperature, humidity, smoke density, and gas concentrations. The collected data is then transmitted via wireless communication networks to a central control station, where advanced data analysis algorithms are employed. These algorithms scrutinise the incoming data using anomaly detection and pattern recognition techniques to identify deviations that could signify the presence of a potential fire outbreak. Upon detection, real-time alerts are generated and promptly conveyed to pertinent stakeholders, ranging from local authorities to firefighting units. The robust communication infrastructure

ensures the seamless transmission of alerts, while energy-efficient strategies, including duty cycling and energy harvesting, optimise the lifespan of sensor node batteries.

Moreover, the integration of the system with existing emergency response mechanisms facilitates coordinated actions and efficient resource allocation. To ensure the security and privacy of transmitted data, the methodology incorporates data encryption and secure communication protocols. Rigorous testing and validation processes are conducted to ascertain the system's accuracy and reliability in fire detection scenarios. User training and engagement play a pivotal role in enabling stakeholders to comprehend the system's functionalities and respond effectively to alerts. Lastly, continuous monitoring, maintenance, and improvement initiatives guarantee the system's long-term effectiveness and relevance. By adhering to this methodology, the IoT-based forest fire detection system emerges as a holistic solution that combines cutting-edge technology, data analysis prowess, and collaborative response mechanisms to address the escalating threat of forest fires.

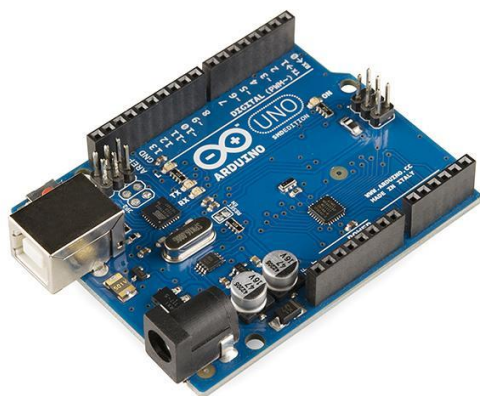

Figure 2: Arduino Uno3

In an IoT-based forest fire detection system, the Arduino Uno can be utilized to connect various sensors that measure temperature, humidity, smoke density, and gas concentrations. The data collected by these sensors can then be processed using the microcontroller's processing capabilities and transmitted to a central control station via wireless communication protocols such as Wi-Fi, Bluetooth, or LoRaWAN.

The Arduino Uno's versatility and community support make it a suitable choice for prototyping and testing components of the IoT system. It can be programmed using the Arduino IDE (Integrated Development Environment) with appropriate libraries and code snippets for sensor interfacing, data analysis, and communication.

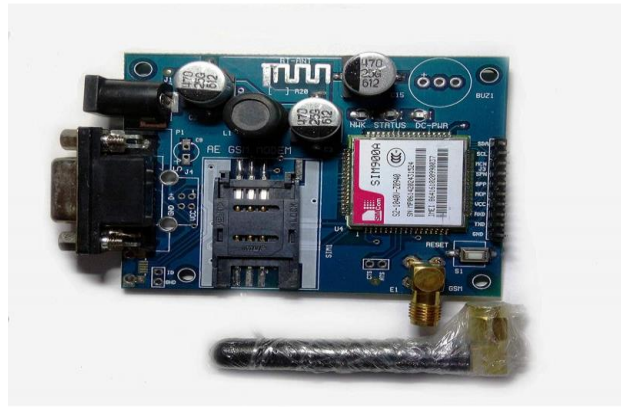

Figure 3: GSM 900A

The GSM 900A module is a type of cellular communication module that operates on the GSM (Global System for Mobile Communications) network frequency band of 900 MHz. This module allows devices to establish a connection to mobile networks, enabling them to send and receive data over cellular networks. The GSM 900A module can be used for various applications, including IoT projects, remote monitoring systems, and communication devices.

In the context of an IoT-based forest fire detection system, the GSM 900A module can play a crucial role in transmitting alerts and data from remote sensor nodes to a central control station or relevant stakeholders.

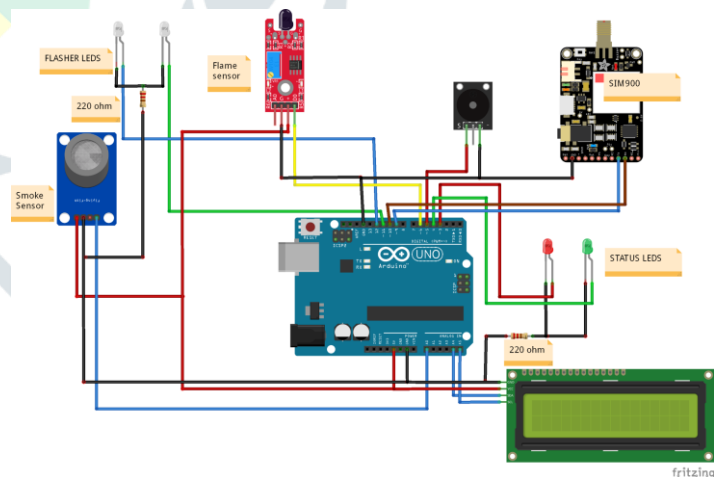

Figure 4 : Simulation of project

An IoT-based forest fire detection system employs a network of strategically placed sensors to monitor environmental variables such as flame, smoke density, and gas concentrations in forested areas. These sensors transmit real-time data to a central control station, where sophisticated data analysis algorithms identify anomalies that could indicate the presence of a fire. Upon detection, the system generates immediate alerts through various communication channels, including SMS, and ensuring swift response from firefighting agencies and local authorities. This technology not only enhances early fire detection but also facilitates informed decision-making,

optimised resource allocation, and coordinated emergency response efforts. By harnessing the power of the Internet of Things, this innovative solution contributes to mitigating the devastating impact of forest fires on ecosystems, property, and lives while fostering sustainable coexistence with nature.

IV Advantages and Impact:

The adoption of an IoT-based forest fire detection system presents a multitude of advantages and a transformative impact on the landscape of wildfire management and environmental preservation. This section delves into the benefits of this innovative system and discusses its implications for ecosystem protection, community safety, and firefighting efficiency.

1. Early Detection and Rapid Response:

One of the primary advantages of the IoT-based system is its unparalleled ability to detect forest fires at their earliest stages. The constant monitoring of environmental parameters, such as temperature, humidity, and smoke density, enables the system to identify subtle deviations that may indicate the presence of a fire. This early detection empowers firefighting teams to respond swiftly, significantly reducing the time required to mobilise resources and contain the fire. Consequently, the potential for fire spread is minimised, leading to reduced damage to ecosystems, property, and human lives.

2. Real-time Alerts and Coordination

The real-time nature of the system's alert generation is a game-changer in emergency response. By instantly transmitting alerts to forest rangers, firefighters, and relevant authorities, the system ensures a rapid and coordinated response. This synchronicity enhances communication and collaboration among various teams, enabling them to make informed decisions and allocate resources effectively. The result is a more efficient and agile approach to firefighting, where stakeholders can adapt strategies based on real-time data.

3. Remote Monitoring and Situational Awareness:

The IoT-based system's remote monitoring capabilities offer a holistic view of forest conditions, regardless of geographical barriers. Authorized personnel can access sensor data and monitor the forest's health, weather patterns, and potential fire risks from a centralized location. This heightened situational awareness allows for proactive decision-making and early intervention, even in remote or inaccessible areas.

4. Minimized Environmental Impact

The system's swift response and effective firefighting reduce the extent of forest fire damage. This, in turn, mitigates the environmental impact of wildfires, preserving delicate ecosystems, wildlife habitats, and biodiversity. By

preventing large-scale destruction, the system contributes to the overall health and sustainability of natural landscapes.

5. Enhanced Community Safety:

Communities residing in fire-prone areas stand to benefit significantly from the implementation of the IoT-based system. The system's ability to detect fires in their early stages provides communities with more time to evacuate and take necessary safety measures. By enabling timely alerts and evacuation efforts, the system helps safeguard lives and property, minimizing the devastating impact on local communities.

6. Improved Resource Allocation:

The precise and data-driven approach of the system optimises resource allocation in firefighting efforts. By pinpointing the fire's location and predicting its trajectory, responders can allocate personnel, equipment, and firefighting strategies more efficiently. This results in reduced wastage of resources and a streamlined approach to fire containment.

7. Valuable Data for Research and Planning:

The continuous collection of environmental data by the system yields a wealth of information that goes beyond fire detection. Researchers can utilise this data to study ecological trends, climate patterns, and the interplay between fires and vegetation. Such insights inform land management strategies, climate change adaptation plans, and wildfire modelling, enhancing the broader understanding of ecosystems and natural processes. In summary, the adoption of an IoT-based forest fire detection system marks a transformative leap in the field of wildfire management. Its ability to provide early warnings, facilitate rapid responses, and optimise resource utilisation has the potential to minimise the destructive impact of wildfires on both natural environments and human communities. By harnessing the capabilities of technology, this system serves as a powerful tool for preserving ecosystems, protecting lives, and promoting sustainable coexistence with the natural world.

V. Challenges and Solutions

While an IoT-based forest fire detection system offers numerous advantages, it also faces several challenges that need to be addressed for successful implementation and operation. This section outlines the key challenges and presents potential solutions to overcome them, ensuring the effectiveness and reliability of the system.

1. Energy Efficiency:

Challenge: Sensor nodes require a sustainable power source to operate continuously, especially in remote forested areas where access to electricity might be limited.

Solution: Implement energy-efficient techniques such as duty cycling, where sensors alternate between active and sleep modes to conserve power. Additionally, explore energy harvesting methods, like solar panels or kinetic

energy converters, to supplement or recharge sensor batteries.

2. Data Security:

Challenge: Transmitting sensitive environmental data over wireless networks raises concerns about data privacy and potential breaches.

Solution: Utilize encryption protocols to secure data during transmission, preventing unauthorized access. Employ secure authentication mechanisms to ensure that only authorized entities can access and manipulate the system's data.

3. Communication Reliability:

Challenge: Remote forest locations might have poor connectivity or face interruptions, affecting the timely transmission of data and alerts.

Solution: Utilize hybrid communication approaches, combining multiple communication protocols (e.g., cellular, satellite, and mesh networks) to ensure reliable and redundant connectivity. Implement data buffering mechanisms to store data temporarily during communication outages.

4. Integration with Existing Systems:

Challenge: Integrating the IoT-based system with established emergency response protocols and agencies might require significant coordination and adaptations.

Solution: Collaborate with relevant stakeholders, including firefighting agencies, to align the system's protocols with existing procedures. Develop APIs and interoperable systems to ensure seamless integration and data exchange.

5. Environmental Factors:

Challenge: Adverse weather conditions, physical obstacles, and natural interferences might impact the accuracy and reliability of sensor data.

Solution: Deploy sensors strategically to minimize their exposure to environmental factors that can affect their readings. Incorporate redundancy in sensor placements to account for potential data inconsistencies.

6. User Education and Training:

Challenge: Ensuring that authorized personnel are trained to interpret system alerts and respond effectively can be a challenge.

Solution: Provide comprehensive training programs for users and stakeholders to understand the system's capabilities, limitations, and proper response protocols. Offer regular updates and workshops to keep them informed about system enhancements and best practices.

7. Scalability and Maintenance:

Challenge: As the system expands to cover larger forested areas, maintaining and managing a growing number of sensor nodes can become complex.

Solution: Develop a scalable architecture that allows for the easy addition of new nodes. Implement remote management tools for system diagnostics, updates, and maintenance, reducing the need for physical intervention.

In conclusion, addressing these challenges through innovative solutions is essential for the successful implementation and sustained effectiveness of an IoT-based forest fire detection system. By overcoming these obstacles, the system can fully realise its potential in revolutionising wildfire prevention and management, ultimately contributing to safer ecosystems and more resilient communities.

VI .Future Directions:

The trajectory of IoT-based forest fire detection systems extends beyond their current capabilities. Anticipating advancements and potential developments is crucial for ensuring the continuous improvement and effectiveness of these systems. This section explores the potential future directions that IoT-based forest fire detection systems could take:

1. Integration of Advanced Sensor Technologies:

Continued research into sensor technologies could lead to the development of more sophisticated sensors capable of detecting even subtle changes in environmental conditions. Integration of multispectral sensors, hyperspectral cameras, and advanced gas sensors could provide more comprehensive data for improved fire detection accuracy.

2. Edge Computing and Local Decision-Making

The adoption of edge computing, where data analysis occurs locally at the sensor nodes, could reduce the burden on centralized control stations. Sensor nodes equipped with sufficient computational power could make local decisions about fire detection, minimizing response time and communication overhead.

3. Global Collaboration and Data Sharing:

International collaboration in sharing fire-related data and insights could lead to a global network of forest fire detection systems. This interconnected approach would provide a broader perspective on fire trends, enable coordinated responses to transboundary fires, and enhance our understanding of fire's global impact.

4. Environmental Monitoring Beyond Fires:

IoT-based systems could evolve to monitor broader environmental parameters, such as air quality, ecosystem health, and climate change indicators. This expanded scope

would provide valuable data for ecological research, land management, and climate modeling.

8. Public Participation and Citizen Science:

Engaging the public in data collection and analysis through citizen science initiatives could harness collective intelligence for fire detection. Mobile apps and crowd-sourced data could supplement sensor networks, increasing coverage and enhancing the accuracy of fire detection.

9. Ethical and Societal Considerations:

As these systems evolve, addressing ethical concerns related to data privacy, public engagement, and algorithmic bias becomes crucial. Transparency, inclusivity, and responsible data governance should be central considerations in future developments.

In summary, the future of IoT-based forest fire detection systems is characterized by continuous innovation, technological integration, and a broader understanding of their potential applications. As research progresses and technology evolves, these systems have the potential to become even more sophisticated tools in our fight against wildfires, fostering safer environments and sustainable coexistence with our natural world.

VII. CONCLUSION

In conclusion, the integration of the Internet of Things (IoT) into forest fire detection systems holds immense promise for revolutionising wildfire prevention and management. The urgency to address the increasing frequency and severity of forest fires has spurred the development of innovative solutions, and the IoT-based forest fire detection system stands out as a beacon of hope in this context.

By strategically deploying sensor nodes equipped with advanced environmental sensors, this system offers real-time monitoring capabilities that extend beyond the capabilities of traditional methods. The ability to continuously gather data on temperature, humidity, smoke, and gas levels enables the system to detect the earliest signs of fire ignition, facilitating timely response and intervention.

The heart of the system lies in its intelligent data analysis algorithms, which scrutinise the incoming data for patterns indicative of fire. This analytical prowess minimises false alarms while maximising the accuracy of fire detection. The generated real-time alerts, transmitted through secure communication networks, bridge the gap between detection and action, ensuring that relevant authorities can swiftly mobilise resources to mitigate fire spread.

Moreover, the system's integration with existing emergency response infrastructure enhances its impact. Coordinated efforts, facilitated by the system's seamless communication protocols, enable a unified response that capitalises on the power of data-driven decision-making.

This translates to a more efficient and effective approach to firefighting and forest management.

However, challenges persist, ranging from ensuring energy-efficient sensor nodes to addressing data security concerns. Overcoming these hurdles requires continued research, innovation, and collaboration among experts in various fields.

In the grander scheme, an IoT-based forest fire detection system transcends its immediate objective of fire prevention. The rich environmental data collected contributes to ecological research and management efforts. It aids in understanding the interplay between climate, vegetation, and fire, thus informing policies and strategies for long-term sustainability.

In a world grappling with the escalating threats of climate change and its consequences, the IoT-based forest fire detection system stands as a testament to human ingenuity. By harnessing the power of technology to safeguard our natural landscapes, ecosystems, and communities, this system represents a significant step forward in building resilience and fostering a safer coexistence with nature.

VIII. REFERENCES

- [1] Stipanicev D., Vuko T., Krstinic D., Stula M., Bodrozcic L., "Forest Fire Protection by Advanced Video Detection System Croatian Experiences", Split, Croatia, 2006
- [2] Losso A., Corgnati L., Perona G., "Early Forest Fire Detection: Smoke Identification through innovative Image Processing using Commercial Sensors", Environment Including Global Change, Palermo, Italy, 2009
- [3] Kovacs R., Kiss B., Nagy A., Vamos R., "Early Forest Fire Detection System For Vegetable Fire in the Aggtelek National Park", Budapest, Hungary, 2004
- [4] Kelha V., Rauste Y., Buongiorno A., "Forest Fire Detection by Satellites for Fire Control", European Space Agency, Finland, 2000
- [5] Manyangadze T., "Forest Fire Detection for Near Real Time Monitoring using Geostationary Satellite", International Institute for Geo-information Science and Earth Observation, Enschede, Netherland, 2009
- [6] Son B., Her Y., Kim J., "A Design and Implementation of Forest Fire Surveillance System based on Wireless Sensor Network for South Korea", International Journal of Computer Science and Network Security, Vol 6 No. 9B, September 2006
- [7] Hariyawan M.Y., Gunawan A., Putra E.H., "Wireless Sensor Network for Forest Fire Detection", ISSN:1693-6930, Vol. 11, No. 3, pp. 563~574, September 2013
- [8] P.J Vivek , G. Raju , S. Akarsh, "Forest Fire Detection System", International Journal of Innovative Research in Science, Eng

[9] S. D. Dissanayake; P. P. C. R. Karunasekara; , D. D. Lakmanarachchi; A. J. D. Rathnayaka; A. T. L. K. Samarasinghe, "ZigBee wireless vehicular identification and authenticate

[10] F. He; Z. Du; Y. Sun, "Indoor dangerous gas environment detected by mobile robot," in 2009 IEEE International Conference on Robotics and Biomimetic (ROBIO), pp. 396-401.

[11] M. F. Jan; Q. Habib; M. Irfan, Jan, M.F.; Habib, Q.; Irfan, M.; Murad, M.; Yahya, K.M.; Hassan, G.M., "Carbon monoxide detection and autonomous countermeasure system for a steel mill using Wireless Sensor and Actuator Network," in 2010 6th International Conference on Emerging Technologies (ICET), pp. 405-409

[12] V. Jelcic; M. Magno; G. Paci; D. Brunelli; L. Benini, "Design, characterization and management of a wireless sensor network for smart gas monitoring," in 2011 4th IEEE Int. Workshop on Adv. in Sensors and Interfaces (IWASI), pp. 115-120.

[13] Fire Safety in buildings by V.K. Jain

[14] Design of water based fire protection systems by Robert M

