



Optimal Location Of TCSC in a Transmission Line

Dr.M.Karthikeyan

Professor, EEE Department,
Sree Sakthi Engineering College

Abstract—Today's Power scenario Compensation plays a vital role to minimize the losses and to maintain the power transfer capability as maximum. FACTS devices are used for compensation and also to control the power flow of an existing long transmission line. This paper employs a series FACTS device as Thyristor Controlled Series Compensator (TCSC) for the control of the power flow in long distance transmission line. The proposed device with PI controller is used to find the optimal location of TCSC in different locations such as sending end of the transmission line, middle and receiving end of the different lengths of the transmission line. PI controller is employed in each operating mode. The firing circuit engages three single-phase PLL units for synchronization along with the line current. Simulations were carried out using MATLAB Simulink environment. The suitable location and the performance of the proposed model were examined and compared with and without compensation. This proposed device is tested under the different lengths like 300km to 500km. In every increment of 100km, the impedance, real power and reactive power were noted and tabulated. The result reveals that the power transfer capability at the middle of the transmission line is better when comparing with the other ends and also the power flow was controlled throughout the line when compensation is given at the middle of the line.

Key Words:FACTS device, TCSC, PI controller, PLL, MATLAB Simulink.

I. INTRODUCTION

Now-a-days the applications of the Power Electronics devices in Power Systems are very much augmented. It is very much needed to control the power flow, in a long distance transmission line. The FACTS devices are introduced in the power system transmission for the reduction of the transmission line losses and to increase the transfer capability and also to control the power flow in the line. TCSC, is one of the type of series FACTS device, for improving the performance and also to control the power flow in a line.

Series compensation is used in order to decrease the transfer reactance of a power line at rated frequency. A series capacitor installation generates reactive power that in a self regulation manner and balances fraction of the line's transfers reactance. The result is that the line is electrically shortened, which improves the angular stability, voltage stability and also shares the power between parallel lines. Series devices were developed from fixed or mechanically switched compensation to Thyristor Controlled Series Compensation (TCSC). The TCSC consists of a fixed capacitor and a parallel Thyristor Controlled Reactor (TCR).

Ali Raza et al [1] have shunted TCSC in a 500KV long transmission line and also implemented with MATLAB/Simulink environment and tested for different sending end voltages by changing impedance line. Akhilesh A. Nimje et al.[2] have explained about the achievement of the required active and reactive power flow into the line for the purpose of compensation as well as validation of enhancement of the power transfer capability of a transmissionline when Interline Power Flow Controller acts as standalone as SSSC. Rajderkar et al.[3] have elaborated the comparison between TCSC and SSSC to solve problems such as congestion management under normal and contingency conditions. The controlling and modeling aspects of TCSC [4] were illustrated. Sun et al.[5] have presented the dynamic response of TCSC and reactance control method. Del Rosso et al. [6] have applied a new controller design of TCSC for enhancement of power system stability. Fuerte-Esquivel et al.[7] have proposed a TCSC model for the power flow solution to the practical networks. Kazerani et al. [8] have generated the power flow control schemes for series connected FACTS controllers. The problem of sub synchronous resonance [9] was rectified using TCSC in a long distance transmission lines. The different sub synchronous frequencies [10] of TCSC were analysed by Kabiri. Kazemi et al.[11] have generated the Genetic Algorithm technique to find the optimal location of TCSC and also to reduce the loss in a transmission line. Singh et al. [12] have optimally selected the location of FACTS devices for the congestion management under normal and abnormal conditions.

In this paper studies were conducted on TCSC at different locations of the long transmission line such as sending end, middle and the receiving end of the long distance transmission line when the length of the line is 300km, 400km and 500km. In every part of the location the power flow is tested with and without compensation strategy. The results of the study were calculated and tabulated in

table 1. A mathematical modeling approach and control design is presented in this work. The simulink model of the standard system is developed and tested using MATLAB Simulink environment.

II. OPERATING PRINCIPLE

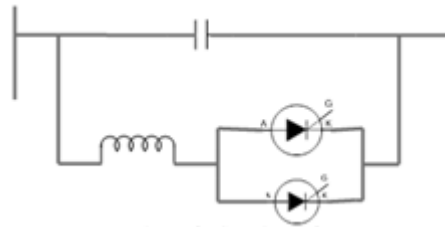

Figure 1 Configuration of TCSC

Figure 1 explains about the configuration of TCSC. In the above configuration a TCR is used in parallel with a fixed capacitor for enabling the continuous control over the series compensation. TCSC can be used to mitigate the SSR even though harmonics are present in steady state with partial conduction of thyristor switches.

A single line diagram of TCSC is shown in figure 2. In this diagram two modules are connected in series. Depends on the requirements either one or two modules are used. To reduce the cost, TCSC may be used in conjunction with fixed series capacitors. Each module has three operation modes.

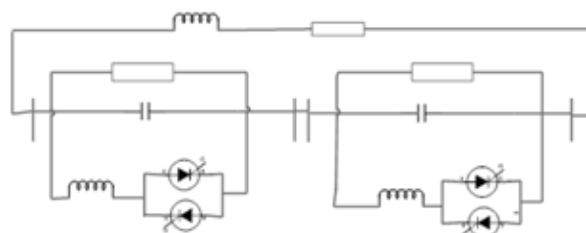

Figure 2 Single Line Diagram of TCSC

A. Bypassed mode

The thyristor valves are gated for 180° conduction (in each direction) and the current flow in the reactor is continuous and sinusoidal. The net reactance of the module is slightly inductive as the susceptance of the reactor is larger than that of the capacitor. The figure 3 shows the operation of bypassed mode. During this mode, most of the line current is flowing through the reactor and thyristor valves with some current flowing through the capacitor. This mode is used mainly for protecting the capacitor against over voltages. This mode is also termed as TSR (Thyristor Switched Reactor) mode.

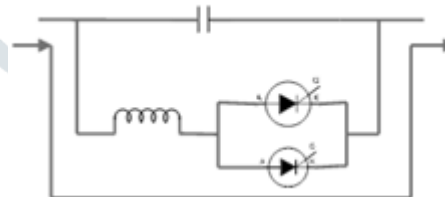

Figure 3 Operation of TCSC - Bypassed Mode

B. Thyristor blocked mode

The figure 4 elaborates the operation of thyristor blocked mode. In this operating mode no current flows through the valves with the blocking of gate pulses. Here, the TCSC reactance is same as that of the fixed capacitor and there is no difference in the performance of TCSC in this mode with that of a fixed capacitor. Hence this operating mode is generally avoided. This mode is also termed as waiting mode.

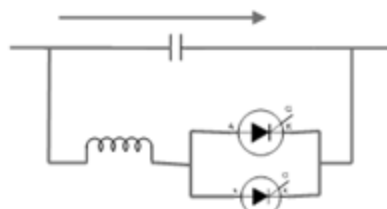

Figure 4 Operation of TCSC - Blocked Mode

C. Vernier control mode

The figure 5 shows the operation of Vernier Control mode. In this operating mode, the thyristor valves are gated in the region of ($\alpha_{min} < \alpha < 90^\circ$) such that they conduct for the part of a cycle.

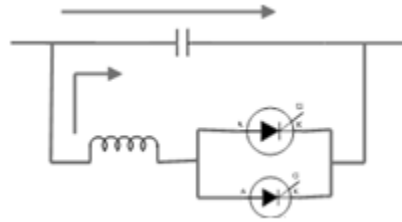

Figure 5 Operation of TCSC – Vernier Control Mode

The effective value of TCSC reactance (in the capacitive region) increases as the conduction angle increases from zero. α_{min} is above the value of α corresponding to the parallel resonance of TCR and the capacitor. In the inductive vernier mode, the TCSC (inductive) reactance increases as the conduction angle reduced from 180° . Generally, vernier control is used only in the capacitive region and not in the inductive region.

III. MODELING OF TCSC

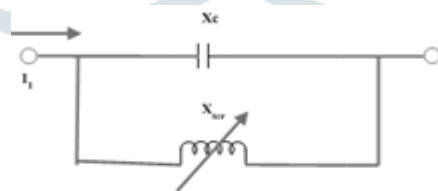

Figure 6 Equivalent Circuit of TCSC

Consider the following figure 6. It explains about the equivalent circuit of TCSC. In this equivalent circuit TCSC is modeled as a capacitor in parallel with a variable inductor. The impedance of the TCSC[13] is given by,

$$Z_{tcsc} = \frac{-jX_c jX_{tr}}{j(X_{tr} - X_c)} \quad (1)$$

$$Z_{tcsc} = \frac{-jX_c}{\left(1 - \frac{X_c}{X_{tr}}\right)} \quad (2)$$

The current through TCR is given by

$$\vec{I}_{tr} = \frac{-jX_c}{j(X_{tr} - X_c)} \vec{I}_L \quad (3)$$

$$\vec{I}_{tr} = \frac{\vec{I}_L}{\left(1 - \frac{X_{tr}}{X_c}\right)} \quad (4)$$

When the losses are neglected, the impedance of TCSC is purely reactive. The capacitive reactance of TCSC is obtained from equation (2) as

$$X_{tcsc} = \frac{X_c}{\left(1 - \frac{X_c}{X_{tr}}\right)} \quad (5)$$

Where X_{tcsc} is capacitive reactance as long as $X_c < X_{tr}$. When $X_{tr} = \infty$ then the thyristors are blocked and $\vec{I}_{tr} = 0$. For the condition $X_c < X_{tr}$, \vec{I}_{tr} is 180° out of phase with the line current phases \vec{I}_L . By simply saying, \vec{I}_L is in phase with $-\vec{I}_{tr}$. The operation of the capacitive condition is shown in figure 7. When $X_c > X_{tr}$, the effective reactance of TCSC is negative. That is it behaves like an inductor. In this condition \vec{I}_L is in phase with \vec{I}_{tr} . The operation of the inductive condition is shown in figure 8.

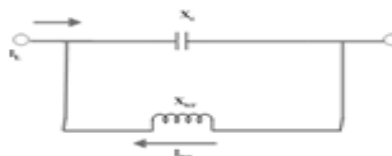

Figure 7 Capacitive Operation of TCSC

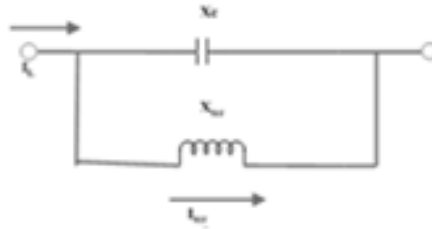

Figure 8 Inductive Operation of TCSC

IV. TCSC CONTROL & IMPEDANCE CALCULATION

In general TCSC operates in the constant impedance mode it uses voltage and current feedback for calculating the TCSC impedance. The reference impedance indirectly determines the power level, although an automatic power control mode could also be introduced. A separate PI controller is used in each operating mode. The capacitive mode also employs a phase lead compensator. Each controller further includes an adaptive control loop to improve performance over a wide operating range. The controller gain scheduling compensates for the gain changes in the system, caused by the variations in the impedance [14].

The firing circuit uses three single-phase PLL units for synchronization with the line current. Line current is used for synchronization, rather than line voltage, since the TCSC voltage can vary widely during the operation. The figure 9 explains about the impedance calculations of TCSC at sending end of the long transmission line. Similarly the impedance is calculated at the middle of the line and receiving end of the long transmission line.

This circuit will run as an inductive mode upto 0.5 seconds and after that it will run as a capacitive mode. Here the reference impedance is selected as 128 ohms.

V. SIMULATION OF TCSC

Figure 10 explains about the circuit without TCSC. The results were obtained without TCSC. Then TCSC is connected at the sending end of the transmission line which is illustrated in Figure 11. Consider a system in which TCSC is placed on a 500KV, 400Km long transmission line, with an objective to improve the power transfer and to control the power flow. In the absence of TCSC device the active power transfer is around 57.17 MW, during the period of first 0.5s of the simulation when the TCSC is bypassed, TCSC will work in inductive mode.

The TCSC can operate in capacitive or inductive mode, although the latter is rarely used in practice. Since the resonance for this TCSC is around 58° firing angle, the operation is prohibited in firing angle range $49^\circ - 69^\circ$. The resonance for the overall system (when the line impedance is included) is around 67° . The capacitive mode is achieved with firing angles $69^\circ - 90^\circ$. The impedance is lowest at 90° , and therefore power transfer increases as the firing angle is reduced.

Similarly TCSC is placed at the middle of the transmission line and receiving end of the transmission line. Then the results were obtained.

VI. SIMULATION RESULTS

For the first 0.5s, the TCSC is bypassed using the circuit breaker, and the power transfer is less. At 0.5s TCSC begins to regulate the impedance to 128 Ohm and this increases power transfer. In capacitive mode the range for impedance values is approximately 120-136 Ohm when it is operated after 0.5 seconds and TCSC is connected at the sending end of the line. This value is also increased up to 300 ohm when TCSC is connected at the receiving end of the line. Testing is done for the different length of the transmission line like 300Km, 400Km and 500Km. For each length of the line the impedance, Real Power and reactive power are noted and tabulated. And also the power transfer capability of the line was calculated. Comparing with the power transfer in an uncompensated line, TCSC enables significant improvement in power transfer level. The waveforms are obtained from the scope of the simulation diagram.

Figure 12 and 13 show that the voltage and current at the bus B1 when TCSC is not connected in the line and TCSC is connected with transmission line.

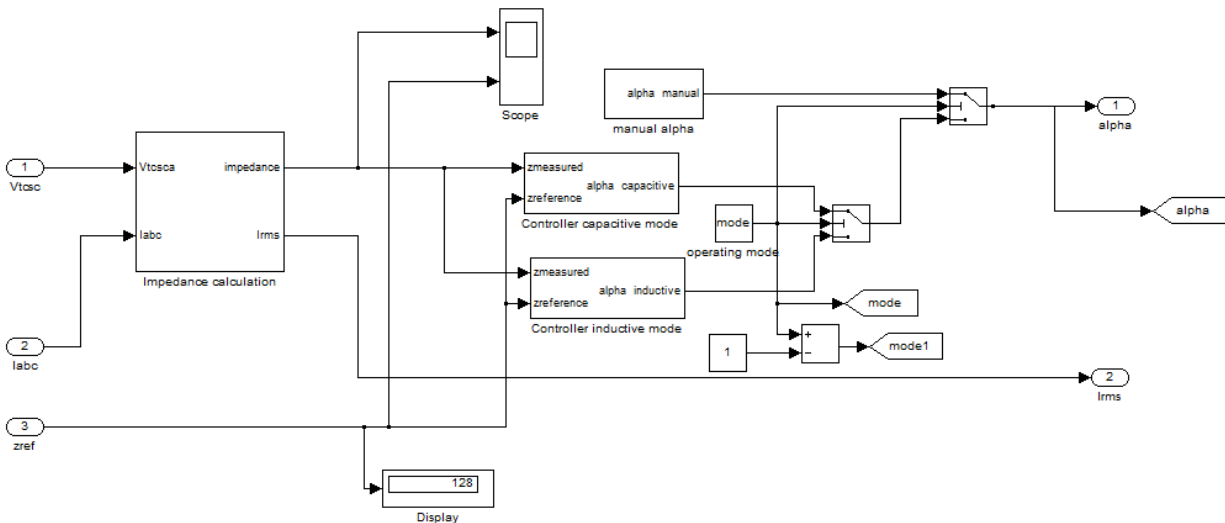

Figure 9 Impedance Calculation of TCSC

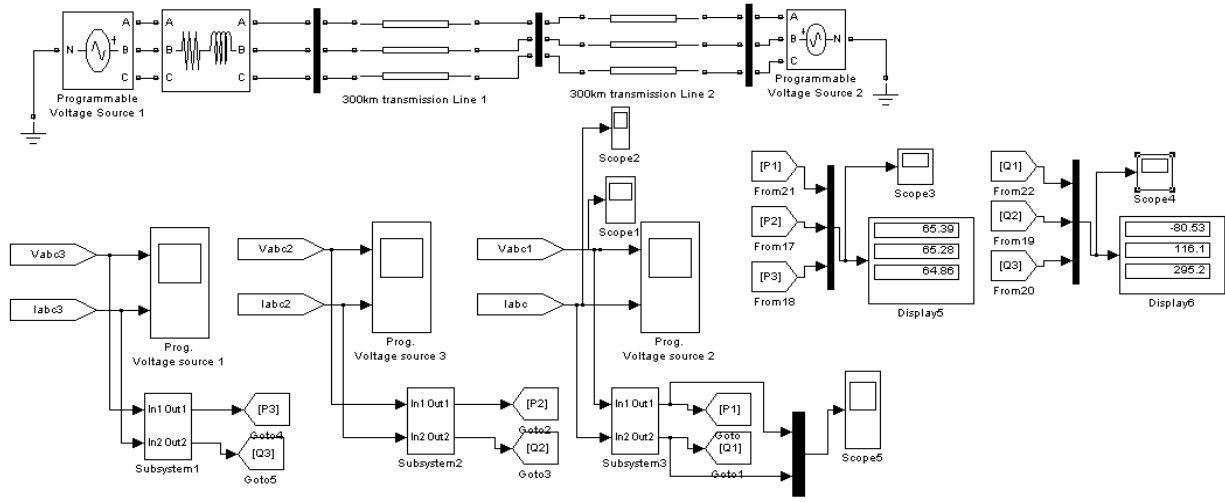

Figure 10 Circuit without TCSC

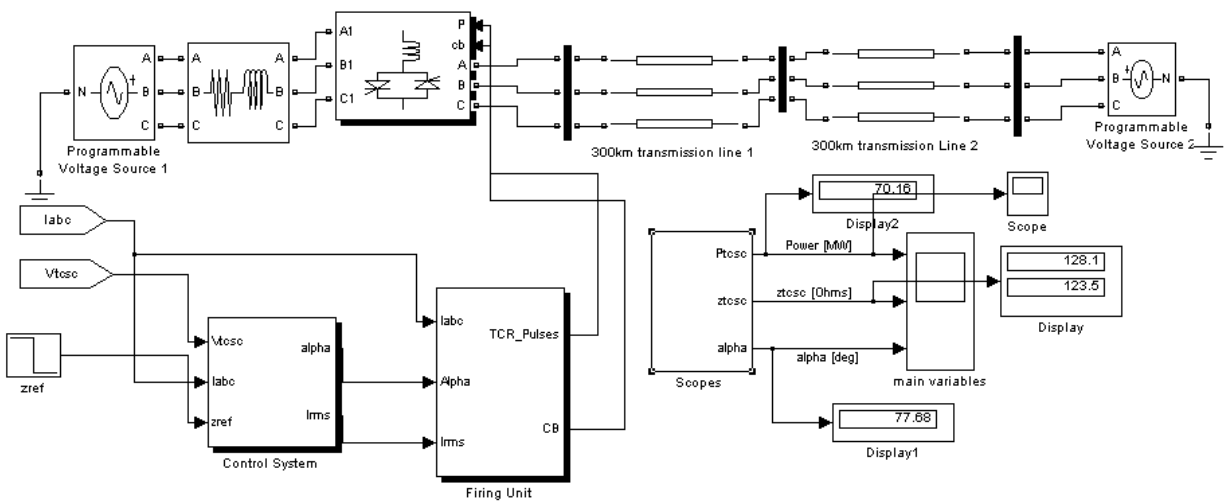

Figure 11 TCSC is at the Sending End of the Line

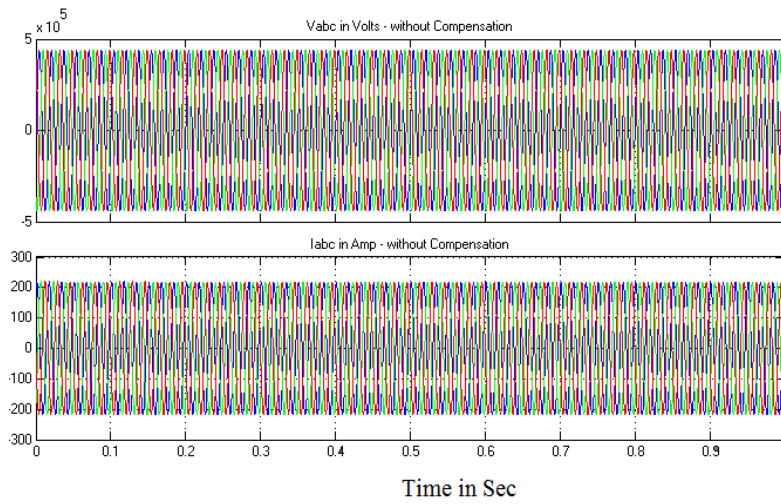

Figure 12 Vabc&Iabc – Without TCSC

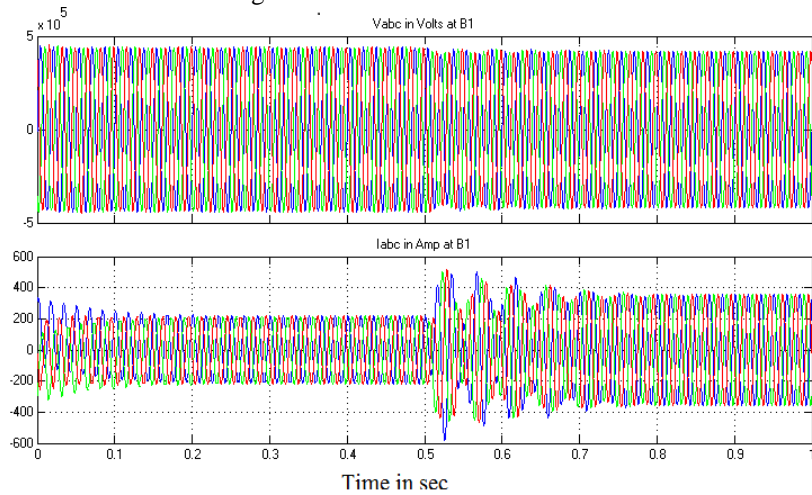

Figure 13 Vabc&Iabc – With TCSC

The Power transfer capability and the power flow of the long transmission line when the length is 300km, 400km and 500km are also verified without connecting the TCSC and with TCSC, which is shown in table 1. The fig.14 shows that the connection with and without TCSC in different locations and the power transfer capability.

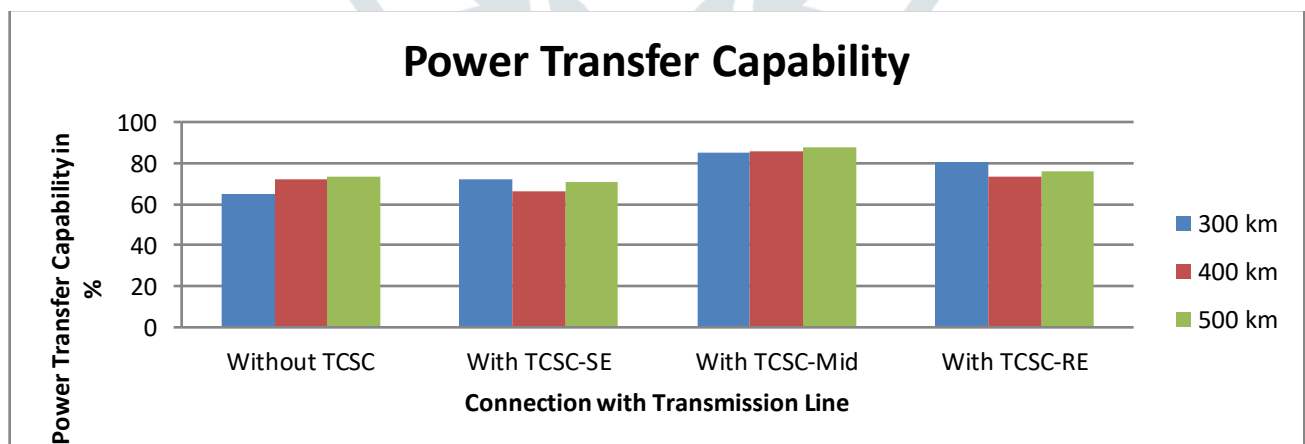

Figure 14 Comparison of PTC

TABLE 1 Real and Reactive Power at B1,B2& B3

Length In KM	At B1		At B2		At B3		PTC in %
	P in MW	Q in MVA _r	P in MW	Q in MVA _r	P in MW	Q in MVA _r	
TCSC is at Sending End							
300	112.8	-142.2	102	44.43	81.7	224.5	72.43
400	94.05	-204.6	82.78	52.68	62.29	296.1	66.23
500	90.82	-210.5	87.6	56.78	64.3	298.6	70.79
TCSC is at Middle							
300	100.5	-1.357	89.03	189.1	85.47	363.2	85.04
400	88.51	-48.16	76.02	216.8	75.83	400	85.67
500	82.65	-58.97	78.42	227.5	72.35	410	87.53
TCSC is at Receiving End							
300	97.5	126.1	89.66	255.3	78.79	448.3	80.8
400	70.28	91.31	61.65	274.1	51.59	511.3	73.41
500	65.87	85.6	60.25	286.3	50.23	529.8	76.26
Without TCSC							
300	60.8	-80.74	49.81	116	39.4	295.3	64.81
400	57.17	-131.4	55.71	147	41.16	386.8	71.99
500	55.2	-152.6	50.62	159.5	40.58	401.8	73.51

VII. CONCLUSION

The vital role of series FACTS devices, which are connected in long distance transmission lines, are to improve the power transfer capability of the transmission line and also to control the power flow in the power system network. In this proposed work TCSC is employed as a series FACTS device. TCSC is connected at the various locations such as sending end, middle and receiving end of the transmission line. The testing has done when the length of the transmission line are 300km, 400km and 500km long. The results were obtained with and without TCSC device. The simulation results reveals that the power transfer capability at the middle of the transmission line is better when comparing with the other ends and also the power flow was controlled throughout the line when compensation is given at the middle of the line. The results show that the impedance increases when the length of the transmission line is increased. The numerical results of the system were elaborated in the table 1. The simulation results were carried in MATLAB Simulink environment.

REFERENCES

- [1] Ali Raza, Haroon Farook, Manzoor Ellahi, Waqas Ali and Muhammad Nasir Khan, "Design and Implementation of TCSC for 500KV for power Transmission System", 3ctecno.2019. special issue.13, , Jan 2019
- [2] Akhilesh A. Nimje, Chinmoy Kumar Panigrahi and Ajaya Kumar Mohanty, "Enhanced of Power Transfer Capability Using SSSC", Journal of Mechanical Engineering Research Vol. 3 (2), pp. 48-56, February 2011
- [3] V.P.Rajderkar, V.K.Chandrakar, Comparison of Series FACTS Devices Via Optimal Location in a Power System for Congestion Management", IEEE, 978-1-4244-2487-0/09,2009
- [4] P.Vuorenpää, P.Järventausta, "Dynamic Modeling of Thyristor Controlled Series Capacitor in PSCAD and RTDS Environments", NORPIE/2008, Nordic Workshop on Power and Industrial Electronics, June 9-11, 2008.
- [5] H-S. Sun, S. Cheng, J. Wen, "Dynamic Response of TCSC and Reactance Control Method Study", Proceedings of POWERCON, 22-26 October, 2006, Chongqing, China. 1-5 p.
- [6] A.D. Del Rosso, C. A. Canizares, V. M. Dona, " A Study of TCSC Controller Design for Power System Stability Improvement.", IEEE Trans. on Power Systems, vol.18, no. 4, Nov. 2003, pp. 1487-1496.
- [7] C.R.Fuerte-Esquivel, E.Acha, and H.Ambriz-Perez, "A Thyristor Controlled Series Compensator Model for the Power Flow Solution of Practical Power Networks", IEEE Trans. Power Systems Vol 15(1), pp 58-64 Feb 2000.
- [8] Y. Ye, M. Kazerani, "Power Flow Control Schemes for Series-Connected FACTS Controllers," *Electric Power Systems Research*, **76**(2006), pp. 824–831.
- [9] P.Vuorenpää, T. Rauhala, P. Järventausta, "On Effect of TCSC Structure and Synchronization Response on Subsynchronous Damping", IPST 2007 Conference Proceedings, Lyon, France, June 4-7, 2007.
- [10] K. Kabiri, S. Henschel, H. W. Dommel, "Resistive Behavior of Thyristor-Controlled Series Capacitors at Subsynchronous Frequencies", IEEE Trans. Power Delivery, Vol. 19, No. 1, January 2004, pp. 374-379.
- [11] A.Kazemi, S. Jamali, M Habibi and S.Ramezan-Jamaat, " Optimal location of TCSCs in a power system by means of genetic algorithms considering loss reduction", IEEE power and energy conference 2006, pp 134-139, 28-29 Nov. 2006.
- [12] S.N. Singh, A.K. David, "Optimal location of FACTS devices for congestion management." *Electric Power System Research*, Vol.58, pp 71-79, 2001.
- [13] K.R.Padiyar, "FACTS Controllers In Power Transmission And Distribution", New Age International Publishers, New Delhi, 2007.

[14] Discover the World of FACTS Technology – Technical Compendium, Available at: http://www.energy.siemens.com/co/pool/hq/powertransmission/FACTS/FACTS_Technology_.pdf. Accessed on 10 Jan. 2017.

BIOGRAPHICAL NOTES



Dr. M. Karthikeyan received the B.E degree from Madurai Kamaraj University in 1997, M.E. degree from Vinayaka Missions University in 2007 and Ph.D degree from PRIST University in 2015. Currently he is working as Professor, Department of Electrical and Electronics Engineering, Sree Sakthi Engineering College, Karamadai, Coimbatore. He has more than 24 years of experience in various engineering colleges affiliated to Anna University. He is a life member of ISTE and member in Institution of Engineers (India). He has published more than 5 text books for Anna university affiliated college students. The major books are Power System Analysis, Electromagnetic Theory, Power System operation and control, Electromagnetic Fields and etc. He also reviewed chapters for Tata McGraw Hill published books of Electromagnetic Field, Modern Power System Analysis and etc. He published more than 24 international journals and attended more than 15 international / national conferences and registered 2 patents.

