



The Role of Optical Fibers in Communication Systems

Dr. RashmiRekha

Faculty of Physics, C. M. Sc. College
Darbhanga, Bihar.

Abstract:

Optical fibers are an integral part of modern communication systems, enabling high-speed data transfer and reliable connectivity. They are thin, transparent strands of glass or plastic used to transmit light signals over long distances.

Keywords: Optical fibers, communication systems, data transfer, light signals, connectivity.

I. Introduction:

The optical fibers like, little light highways! The magic behind them is something called total internal reflection, which is a fancy way of saying that light bounces around inside the fiber's core and stays put, instead of escaping. These fibers possess a unique outer layer referred to as cladding, which has a reduced refractive index. This layer is super important because it's what keeps the light contained and on track as it travels through the fiber. One of the main advantages of using optical fibers in communication systems is their high bandwidth capabilities. This means that they can transmit large amounts of data at very high speeds, making them ideal for applications such as internet, television, and telephone services. In this article, we'll discuss the properties and applications of optical fibers in communication systems.

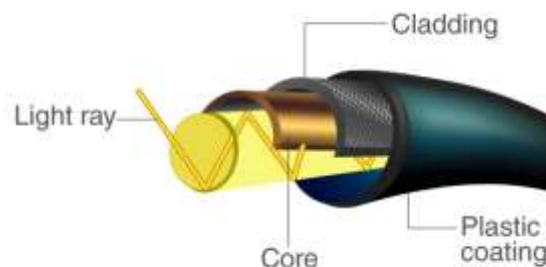

Optical fibers play a crucial role in modern communication systems, providing high-speed and reliable transmission of data, voice, and video signals. With ongoing research and development, it is likely that their applications will continue to expand, making them an essential component of our interconnected world. It has revolutionized the field of communication, enabling high-speed data transfer and reliable connectivity over long distances. Their properties of low attenuation, high bandwidth, and immunity to electromagnetic interference make them an ideal choice for various communication applications. As technology continues to advance, the use of optical fibers is expected to grow, further improving the efficiency and reliability of communication systems. Optical fibers are an essential component of modern communication systems, allowing for fast and reliable transmission of data, voice, and video signals. Furthermore, optical fibers are immune to electromagnetic interference, which facilitates a more dependable and secure transfer of information.

II. Properties of Optical Fibers:

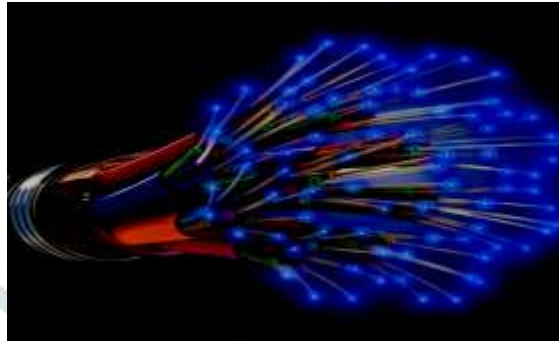

1. **Low Attenuation:** One of the key properties of optical fibers is their low attenuation, which means that they can transmit light signals over long distances without significant loss of signal strength. This is due to the low absorption and scattering of light in the fiber material.
2. **High Bandwidth:** Optical fibers have a much higher bandwidth compared to traditional copper wires. This facilitates the transfer of substantial volumes of data at elevated speeds, rendering them suitable for communication systems.
3. **Immunity to Electromagnetic Interference:** In contrast to copper wires, which are vulnerable to electromagnetic interference, optical fibers are resistant to these disturbances. This makes them a more reliable option for communication systems, especially in areas with high levels of electromagnetic activity.
4. **Compact and Lightweight:** Optical fibers possess a slender and lightweight design, facilitating their installation and transportation. This also allows for a higher density of fibers to be used in a given space, increasing the capacity of the communication system.
5. **Flexibility:** Optical fibers are highly flexible, allowing them to be bent and routed around corners without affecting the transmission of light signals. This makes them suitable for use in various communication applications, including undersea cables and networks.

III. Applications of Optical Fibers in Communication Systems:

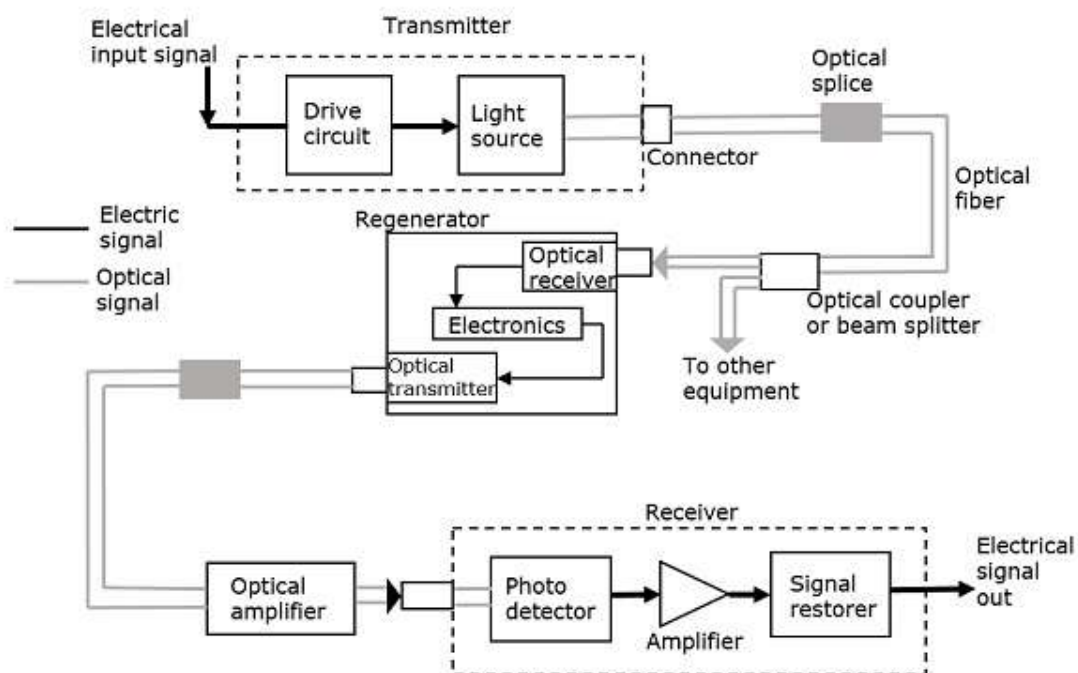

1. **Telecommunications,** where they are used to transmit voice, data, and video signals over long distances. They form the backbone of internet and telephone networks, providing high-speed and reliable connectivity.
2. **Cable Television:** Optical fibers are also used in cable television systems to transmit high-quality video signals to homes. This allows for a larger number of channels and better picture quality compared to traditional coaxial cables.
3. **Local Area Networks (LANs):** Optical fibers are used in LANs to connect computers and other devices within a building or campus. This allows for faster data transfer and more secure communication compared to traditional copper wires.

4. Fiber Optic Sensors: Optical fibers may also serve as sensors for measuring different parameters, including temperature, pressure, and strain. These sensors are used in a wide range of applications, including industrial processes and medical equipment.

5. Military and Aerospace Communication: Optical fibers are used in military and aerospace communication systems due to their immunity to electromagnetic interference and small size. They are also lightweight, making them suitable for use in aircraft and spacecraft.

IV. Conclusion:

The aspect of optical fibers is their low attenuation, which refers to the loss of signal strength as it travels through the fiber. This allows for longer distances between transmission points without the need for signal boosters, reducing the overall cost and complexity of the communication system. The development of new materials and manufacturing techniques has also enabled the production of specialized optical fibers, such as single-mode fibers, which are designed for long-distance transmissions, and multi-mode fibers, which are better suited for shorter distances and high-speed data transmission.

Despite their many advantages, optical fibers also have some limitations. They are fragile and can be damaged if not handled carefully, and their installation and maintenance require specialized equipment and expertise. However, with the continuous advancements in technology, these limitations are being addressed, making optical fibers an increasingly popular choice for communication systems.

References:

1. Agrawal, G. P. (2006). Fiber-optic communication systems. John Wiley & Sons.
2. Keiser, G. (2011). Optical fiber communications. McGraw-Hill Education.
3. Saleh, B. E. A., &Teich, M. C. (2007). Fundamentals of photonics. John Wiley & Sons.
4. Choudhury, P. (2016). Optical communication and networking. CRC Press.
5. Eickhoff, W., &Schäfer, H. (2015). Optical communications. John Wiley & Sons.
6. Khan, S. M. (2012). Fiber-optic communications technology. Pearson Education India.
7. Agrawal, A. K. (2012). Fiber-optic communication systems. Springer Science & Business Media.
8. Ramaswami, R., &Sivarajan, K. N. (2010). Optical networks: a practical perspective. Morgan Kaufmann.
9. Srivastava, A. (2014). Optical fiber communication systems with MATLAB® and Simulink® models. CRC Press.
10. Agrawal, G. P. (2013). Nonlinear fiber optics. Academic Press.