



AI POWERED SMART PILL DISPENSER FOR INTELLIGENT MEDICATION MANAGEMENT

¹Mayur Rajendra Badiger, ²Dr.Shwetha N, ³Jayanth HT, ⁴Ameen Abdulla Khan, ⁵Omkaar R

¹Student, ²Assistant Professor, ³Student, ⁴Student, ⁵Student
¹Department of Electronics and Communications Engineering,
¹Dr. Ambedkar Institute of Technology, Bengaluru, India.

Abstract : Medication non-adherence is a major concern in healthcare, especially among elderly patients and individuals requiring long-term medication. This paper presents the design and implementation of an AI powered smart pill dispenser system aimed at improving medication adherence, safety, and monitoring. The proposed system integrates embedded hardware with artificial intelligence to automate pill dispensing based on predefined schedules. Audio and visual alerts are generated to ensure timely medication intake, while sensors and control logic confirm accurate dispensing and prevent overdose. The system also enables analysis of medication adherence patterns and supports remote monitoring by caregivers through wireless connectivity. Experimental evaluation demonstrates reliable operation, accurate dosage delivery, and effective alert generation. The proposed solution enhances patient independence and contributes to safer and intelligent medication management in modern healthcare systems.

IndexTerms - Smart Healthcare, Pill Dispenser, Artificial Intelligence, Embedded Systems, IoT.

I. INTRODUCTION

Medication management plays a crucial role in healthcare, particularly for elderly individuals and patients suffering from chronic diseases. Improper medication intake such as missed doses, incorrect timing, or accidental overdosing can result in severe health complications and increased hospitalization. Conventional pill organizers and manual reminder systems rely heavily on user memory and discipline, which often leads to poor medication adherence.

With advancements in embedded systems, Internet of Things (IoT), and artificial intelligence, smart healthcare solutions have gained significant attention. Automated medication dispensing systems provide a promising approach to reduce human error and improve adherence. However, many existing systems lack intelligence, adaptability, and real-time monitoring capabilities.

This paper focuses on the development of an AI powered smart pill dispenser system that automates medication dispensing at predefined times. The system ensures accurate dosage delivery and incorporates alert mechanisms to notify users in case of missed doses. Artificial intelligence is utilized to analyze user medication patterns and adapt alert strategies accordingly. Sensors and control logic enhance reliability, while wireless connectivity enables remote monitoring by caregivers or healthcare professionals.

The proposed system is designed to be compact, user-friendly, and cost-effective, making it suitable for home healthcare applications. By automating routine medication tasks and enabling intelligent monitoring, the system improves medication adherence, reduces caregiver burden, and enhances patient safety.

II. SYSTEM ARCHITECTURE

The AI powered smart pill dispenser system consists of embedded hardware modules, sensing units, control logic, and artificial intelligence components integrated into a single architecture. A regulated power supply provides stable voltage to all system modules. The microcontroller functions as the central control unit and interfaces with a real-time clock to maintain accurate timing information for medication schedules. When the scheduled medication time is reached, the controller activates audio and visual alert mechanisms to notify the user. Simultaneously, it triggers the pill dispensing mechanism using motors or actuators to release the prescribed medication. Sensors continuously monitor pill presence and dispensing status to ensure accurate delivery and prevent multiple dispensing events.

An AI processing module analyzes medication adherence data to identify patterns such as missed or delayed doses. Based on this analysis, the system adapts alert intensity and frequency to improve compliance. Wireless communication enables transmission of

dispensing data to caregivers for remote monitoring. The closed-loop architecture ensures accuracy, safety, and reliability in automated medication management.

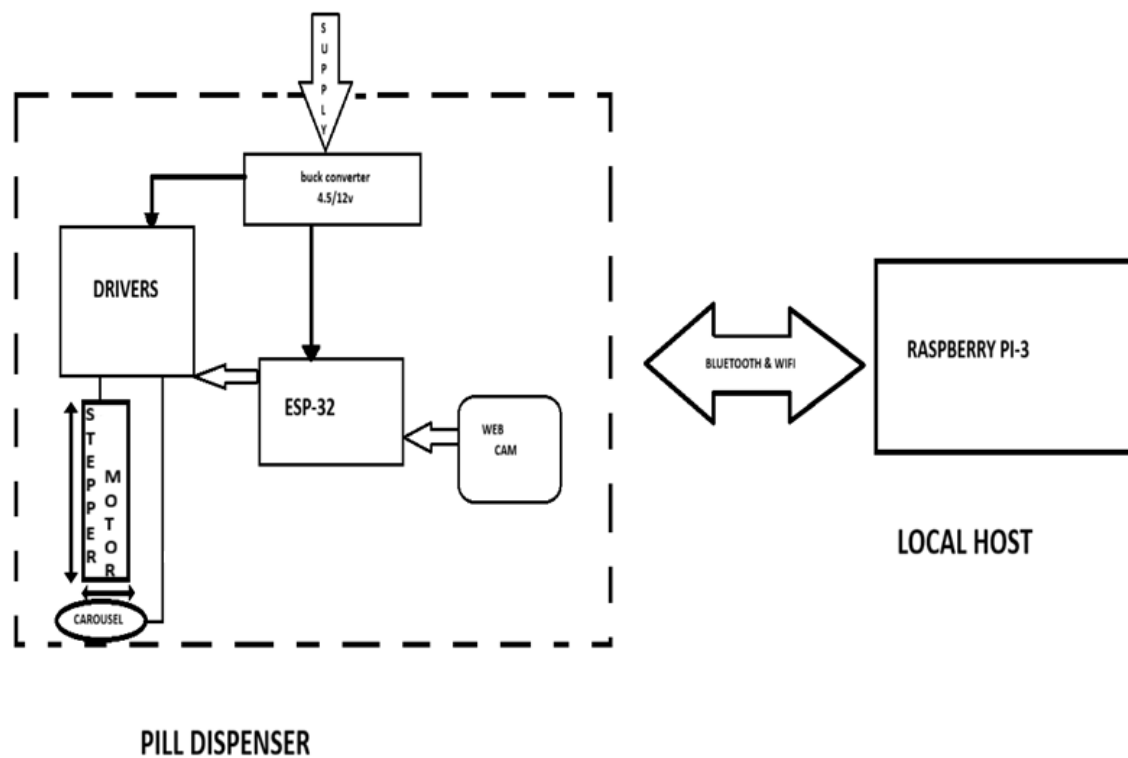

Fig. 1 Block Diagram of AI Powered Smart Pill Dispenser

III. METHODOLOGY

The development of the AI powered smart pill dispenser system follows a structured and systematic approach. Initially, system requirements were analyzed by studying existing medication management solutions and identifying their limitations. Functional requirements such as automated dispensing, accurate timing, alert generation, and overdose prevention were defined. Hardware components including the microcontroller, real-time clock, sensors, motors, and alert units were selected based on reliability and efficiency. Embedded software was developed to control medication scheduling, dispensing logic, and system monitoring. Artificial intelligence algorithms were integrated to analyze medication adherence behavior and generate adaptive alerts. The complete system was tested under different operating conditions to validate accurate dispensing, alert functionality, and safety mechanisms. Performance evaluation confirmed reliable operation and effective medication management. Iterative refinement was carried out to improve system robustness and usability.

IV. SYSTEM FLOWCHART

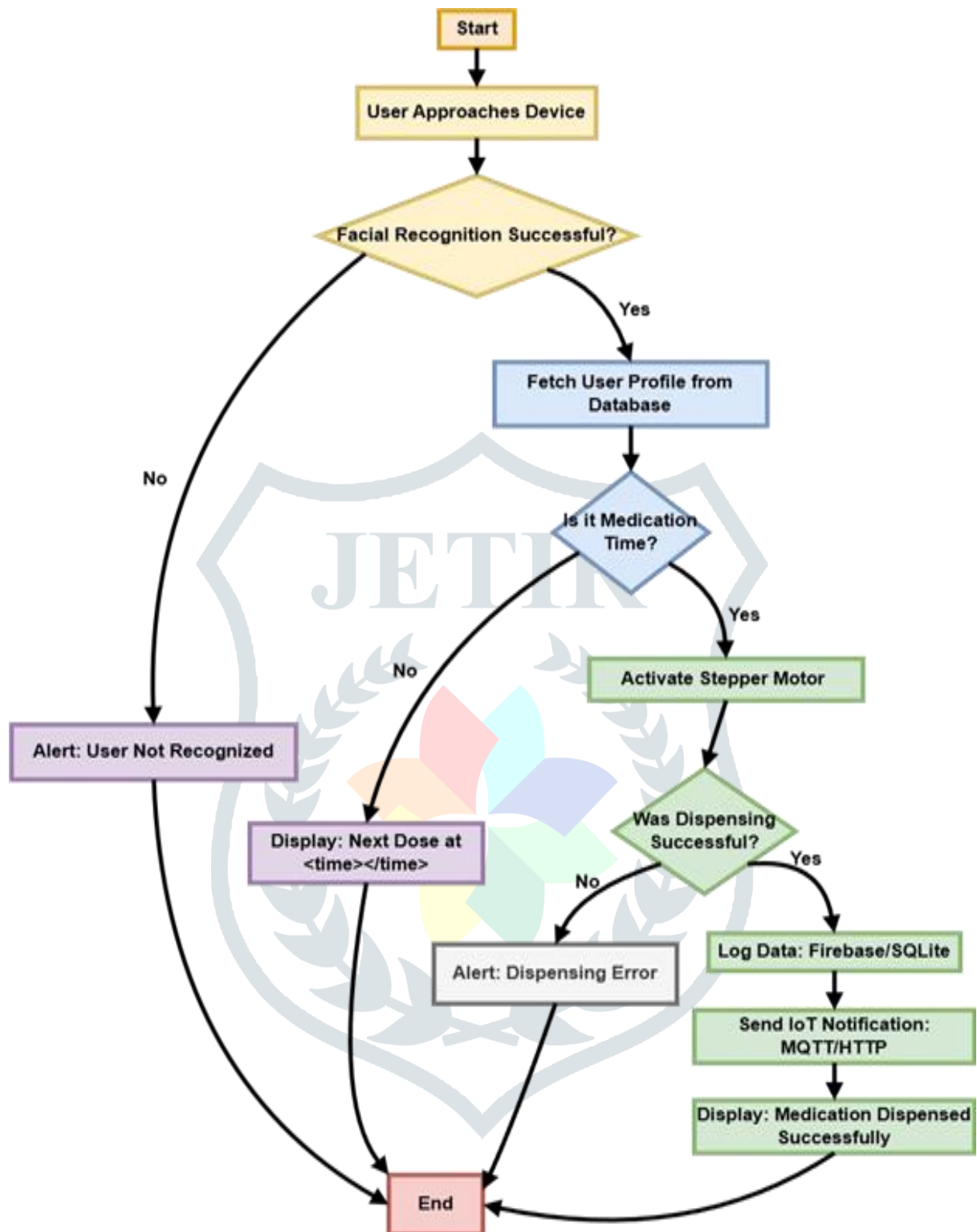

Fig. 2 Flowchart of AI Powered Smart Pill Dispenser System

V. RESULTS AND DISCUSSION

The experimental evaluation of the AI powered smart pill dispenser system demonstrated reliable and accurate performance. The system successfully dispensed medications at predefined schedules with minimal delay. Audio and visual alerts were generated effectively to notify users before dispensing.

Sensor feedback confirmed successful pill dispensing and prevented accidental overdose. The AI-based analysis enabled identification of missed doses and improved reminder strategies. Wireless monitoring allowed caregivers to track medication adherence remotely. Overall, the results indicate that the proposed system significantly improves medication adherence and safety.

VI. CONCLUSION AND FUTURE SCOPE

This paper presented the design and implementation of an AI powered smart pill dispenser system for intelligent medication management. The system automates pill dispensing, ensures accurate dosage delivery, and enhances adherence through intelligent alert mechanisms. Integration of artificial intelligence enables behavior analysis and adaptive reminders, while connectivity supports remote monitoring.

Future enhancements may include mobile application integration, cloud-based data analytics, advanced AI models for predictive adherence analysis, and support for multiple users. The proposed system offers a scalable and practical solution for home-based healthcare applications.

VII. REFERENCES

- [1] B. Das and K. K. Halder, "Real-Time Face Recognition Using ESP32-CAM for Monitoring Applications," *International Journal of Engineering Research and Technology*, 2024.
- [2] T. Diwan, G. Anirudh, and J. V. Tembhrne, "Object Detection Using YOLO: Challenges, Architectural Successors, Datasets and Applications," *International Journal of Computer Vision and Signal Processing*, 2023.
- [3] Imron, B. Satria, and S. Karim, "Cloud Storage for Object Detection Using ESP32-CAM," *International Journal of Advanced Computer Science and Applications*, 2024.
- [4] N. Cameron, "ESP32-CAM Hardware Architecture and Performance Analysis," *Journal of Embedded Systems and Applications*, 2023.
- [5] R. Want, "An Introduction to RFID Technology," *IEEE Pervasive Computing*, vol. 5, no. 1, pp. 25–33, 2006.
- [6] A. Al-Fuqaha, M. Guizani, M. Mohammadi, M. Aledhari, and M. Ayyash, "Internet of Things: A Survey on Enabling Technologies, Protocols, and Applications," *IEEE Communications Surveys & Tutorials*, vol. 17, no. 4, pp. 2347–2376, 2015.
- [7] S. K. Patel, A. N. Patel, and R. R. Patel, "Smart Healthcare Monitoring System Using IoT," *International Journal of Engineering Science and Computing*, vol. 7, no. 6, pp. 13872–13875, 2017.
- [8] M. S. Hossain and G. Muhammad, "Cloud-Assisted Industrial Internet of Things (IIoT): Enabled Framework and Future Challenges," *IEEE Access*, vol. 4, pp. 839–850, 2016.
- [9] J. Gubbi, R. Buyya, S. Marusic, and M. Palaniswami, "Internet of Things (IoT): A Vision, Architectural Elements, and Future Directions," *Future Generation Computer Systems*, vol. 29, no. 7, pp. 1645–1660, 2013.
- [10] P. Gope and T. Hwang, "BSN-Care: A Secure IoT-Based Modern Healthcare System Using Body Sensor Network," *IEEE Sensors Journal*, vol. 16, no. 5, pp. 1368–1376, 2016.

