

# The Fabrication of a Manually Operated Water Lifting Pump.

<sup>1</sup>Swapnil D. Kurhekar, <sup>2</sup>Niraj M. Walchale ,

<sup>1</sup>Asst. Professor, <sup>2</sup> Asst. Professor,

<sup>1</sup>Mechanical Engineering Department

<sup>1</sup>Sanmati Engineering College, Washim , India

## Abstract :

The main purpose of doing this project is to create a dual purpose machine which would help in lifting water and serve the purpose of doing exercise. In our mechanism we have used a bicycle. . The general bicycle consists of large sprockets which have 46 teeth to which pedal are attached. Drive is given to the bigger sprocket which by chain drive is attached to the small sprocket having 17 teeth .Sprocket mounted on circular shaft which is supported by pedestal bearing which are self-aligning ball bearing and also on this shaft rear wheel of bicycle is mounted .In this mechanism connecting media is used as v-belt. This v-belt is connected to rear wheel of bicycle and pulley of centrifugal pump which is attached to circular shaft of centrifugal pump. In this assembly centrifugal pump is fitted 20 mm above the ground with the help of steel frame. This arrangement has been made for proper alignment of v-belt.

**IndexTerms - Pedal, Centrifugal Pump, Pulley, Shaft, Impeller etc.**

## I. INTRODUCTION

Water-lifting devices are used to lift water to a height that allows users easy access to water. Lifting devices can be used to raise groundwater, rainwater stored in an under-ground reservoir, and river water. Communities should be able to choose from a range of water-lifting devices, and each option should be presented with its advantages, disadvantages and implications. For example, water lifting involves additional O&M activities and potential problems, compared to gravity systems, and the latter are often preferred if they are available and applicable to the situation. The following water-lifting devices are described in this manual. There are other water-lifting devices that are not described in this manual, such as the progressing cavities pump, the manual diaphragm suction pump, the treadle pump and the chain pump. Other devices, such as the air-lift pump, are not included because they are not applicable to drinking-water supply systems.

## I. RESEARCH METHODOLOGY

Water-lifting devices are used to lift water to a height that allows users easy access to water. Lifting devices can be used to raise groundwater, rainwater stored in an under-ground reservoir, and river water. Communities should be able to choose from a range of water-lifting devices, and each option should be presented with its advantages, disadvantages and implications. There are other water-lifting devices that are not described in this manual, such as the progressing cavities pump, the manual diaphragm suction pump, the treadle pump and the chain pump. Other devices, such as the air-lift pump, are not included because they are not applicable to drinking-water supply systems.

### a) RACK AND PINION

A rack and pinion is a type of linear actuator that comprises a pair of gears which convert rotational motion into linear motion. A circular gear called "the pinion" engages teeth on a linear "gear" bar called "the rack"; rotational motion applied to the pinion causes the rack to move relative to the pinion, thereby translating the rotational motion of the pinion into linear motion. As we know that input to any mechanism here in this displacement. In rack and pinion mechanism we are using linear displacement as input to get the rotational output at the dynamo shaft.

In this we can attach the rack to the speed breaker so that when the vehicle passes over it, some fixed set amount will displace it. Due to this rack will move down which will cause the rotation of the pinion. The pinion is mounted on the output shaft i.e. dynamo shaft which will consequently rotate on the rotation of the pinion. There are some benefits of these mechanisms such as this is one of the simplest possible. Mechanisms, the overall size of the mechanism is compact and doesn't require much maintenance.

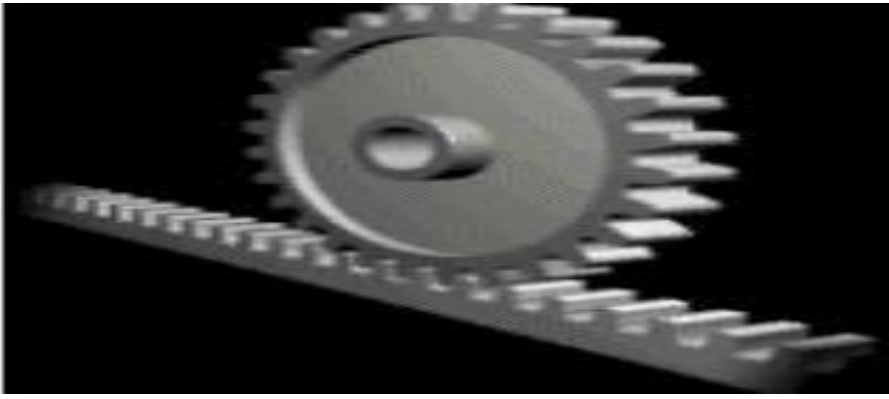

### b) SPROCKET CHAIN

Sprocket or sprocket-wheel is a profiled wheel with teeth, cogs, or even sprockets that mesh with a chain, track or other perforated or indented material. The name 'sprocket' applies generally to any wheel upon which radial projections engage a chain passing over it. It is distinguished from a gear in that sprockets are never meshed together directly, and differs from a pulley in that sprockets have teeth and pulleys are smooth. Sprockets are used in bicycles, motorcycles, cars, tracked vehicles, and other machinery either to transmit rotary motion between two shafts where gears are unsuitable or to impart linear motion to a track, tape etc. Perhaps the most common form of sprocket may be found in the bicycle, in which the pedal shaft carries a large sprocket-wheel, which drives a chain, which, in turn, drives a small sprocket on the axle of the rear wheel. Early automobiles were also largely driven by sprocket and chain mechanism, a practice largely copied from bicycles. Sprockets are of various designs, a maximum of efficiency being claimed for each by its originator. Sprockets typically do not have a flange. Some sprockets used with timing belts have flanges to keep the timing belt centered.



Fig Sprocket Chain

### III DESIGN CONSIDERATION.

After adopting the design procedure we have performed the work of fabrication in the college workshop. The fabrication is done of individual parts simultaneously. The fabrication parts are

- Water chamber
- Chain and sprocket mechanism
- Cylinder and piston
- Water container

#### a) Fabrication of cylinder

The cylinder is made up of galvanized iron .as it has no problem of corrosion. The cylinder is attached to two thick plates of 5 mm thickness and having 4 holes of 10 mm diameter each for the foundation bolt. Delivery pipe is 300 mm long and having diameter 25 mm.

Cylinder outer diameter = 140 mm

Cylinder inner diameter = 130 mm

Height of cylinder = 140mm



Fig Water Chamber.

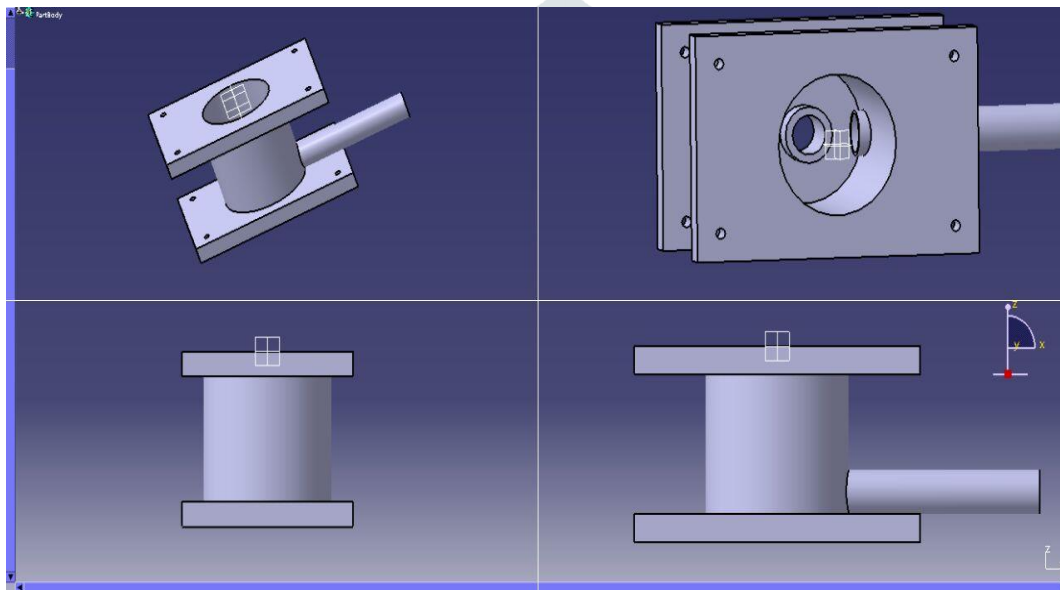

There are various basic relationships between the output or discharge rate ( $Q$ ), piston diameter ( $d$ ), stroke or length of piston travel ( $s$ ), number of strokes per minute ( $n$ ), and the volumetric efficiency, which is the percentage of the swept volume that is actually pumped

if the swept area of the piston is  $A = \frac{\pi d^2}{4}$

the swept volume per stroke will be  $V = As$

the discharge per stroke will be  $q = \eta_{vol} V$

the pumping rate (per minute) is  $Q = nq$

#### b) Sprocket and Chain arrangement

The manual input is obtained by moving handle. the motion obtained is transmitted to chain sprocket arrangement . The Sprocket is having following dimensions

Outer Diameter of Sprocket = 140 mm

Pitch of sprocket =

The smaller sprocket is located at a distance of 140 mm down on from main sprocket it is driven by chain passed over it. Its dimensions are

Outer Diameter of Sprocket = 140 mm



**Fig Sprocket and chain arrangement.**

#### **IV WORKING PRINCIPLE**

Reciprocating suction pump operates because of suction and compression inside cylinder.

**Suction Stroke:** When handle moves downward the piston rod moves upward and water enters into the cylinder through foot valve called as suction stroke.

**Compression Stroke:** During this stroke piston rod moves downward and water enters in the chamber. And piston comes to downward position. In this way pump operates.



**Fig Reciprocating suction pump**

#### **V CONCLUSION**

This project focused on design and fabrication of water pumping device, with emphasis on lightweight, portable appliances. . An innovative method of minimizing manual stress and thus reliably stabilizing the pumping was also presented. The project carried out by us made an impressive task in the domestic purpose. It is very useful for the small scale works. This project has been designed to perform the entire requirement task, which has also been provided

**VI REFERENCES**

1. Colin, J. (1999) "VLOM for Rural Water Supply: Lessons from Experience," Water and Environmental Health at London and Lough brough, WELL Study Task No. 162.
2. Erpf, K. (1998) The Bush Pump, The National Standard Handpump of Zimbabwe HTN/(SKAT) Network for Cost-effective Technologies in Water Supply and Sanitation/Swiss Centre for Development Co-operation in Technology and Management, St., Gallen, Switzerland.
3. Evans, J. "A Brief Introduction to Centrifugal Pumps," Pacific Liquid & Air Systems, Hololulu, HI Felder, R. & Rousseau, R. (1978) Elementary Principles of Chemical Processes, NewYork: John Wiley & Sons.
4. Skinner, B. (1996) "Hand pump standardization," 22ndWEDC Conference 'Reaching the Unreached: Challenges For The 21<sup>st</sup> Century' AOV International, "U3 Modified Deepwell Handpump," Noida, U.P., India .
5. University of Colorado, Boulder; Civil, Environmental and Architectural Engineering Department, "Access to water reduces poverty,"
6. ANSI/HI 6.6, 1994, "Reciprocating Pumps Tests," AmericanNational Standards Institute, Washington, D.C./Hydraulic Institute; Parsippany, New Jersey.ANSI/HI 8.1-8.5, 1994,
7. Handpumps Technology Note WaterAid, 2008 How to Make a Rope-and-Washer Pumpby Robert Lambert, ITDG Publishing, 1990.
8. Impact Of The Rope And Washer Pump In A Water And Sanitation Project, Rift Valley Province, Kenya Angharad Hughes, Stephen Burgess and Andrew Trevett
9. Linking Technology Choice with Operation and Maintenance, Chapter 4 Water Lifting Devices,WHO, 2003
10. Maintaining Handpumps Technical Brief Waterline Smart Water Solutions: Examples of innovative low cost technologies for wells, pumps, storage, irrigation and water treatment,Netherlands Water Partnership, 2006

