

Gain Flattened and C/L Band Amplified Spontaneous Emission Noise Re-injected L-band EDFA

Navjot Singh¹, Dr. Mahendra Kumar², ¹Research Scholar, ²Assistant Professor, ECE Department, Guru Kashi University, TalwandiSabbo, Punjab, India

Abstract: Explosive increase in internet services put peer pressure on conventional band grid (1530-1570 nm) and therefore L-band wide wavelength grid is required to cater the ever-increasing demands. In this work, accentuation is given to enhance the Gain flattening of ultra dense (25 GHz) L-band WDM system using single stage EDFA amplifier when ultra low power is launched from 16 and 32 channels. High Gain and Gain flattening is achieved by incorporating three Fiber Bragg Gratings (FBGs) for amplified spontaneous noise reinjection. Maximum ASE is emerged at 1565 nm for the 1575.69 nm to 1579 nm input wavelengths (16 channels) and 1572.58 to 1579 nm (32 channels) at -55 dBm ultra low carrier powers. To optimize different parameters of L-band EDFA, different physical parameters such as core radius, EDF link lengths, launched powers are varied and results are analyzed in terms of Gain, and Gain flatness. Maximum gain is found out to be 34.12 dB at optimal physical parameters of the EDF with Gain Flatness of ± 0.45 dB in case of 16 channels and ± 1.41 in case of 32 channels.

Keywords- L-band EDFA, ASE, PCE, FBG, Gain,

Introduction

With the evolvement of high capacity data communication systems, Long band erbium-doped fiber amplifiers (L-EDFAs) are getting more attention in recent times [1][2]. Major advantage of the L-band EDFA is that it provides the user to realize a system with wide bandwidth of 45 nm [3]. But, from the reported works, it is evident that the Long band EDFA has low pump conversion efficiency (PCE) and lies at the tail of the EDFA amplification window [4][5][6]. Efficiency of the pump and gain of the EDFA is enhanced in the L-band, either by using the long span of erbium fiber or by increasing the ion concentration of the amplifiers fiber [7]. Numerous works has been witnessed in the gain enhancement of L-band EDFA amplifiers. One of the best techniques was accomplished through seed signal injection of conventional band [8]. In Long band EDFA, prominent and premier technique of amplified spontaneous noise was used by utilizing forward and backward ASE to get the improved gain and less noise figure [9]. This process was done through the narrowband Fiber Bragg Gratings (FBG) or fiber reflectors mirrors [10]. Numerous works has been reported on the Gain flatness of L-band amplifiers using C-band light injection [11], by weak gain-clamped technique [12], a ring laser cavity with fiber bragg grating [13], ASE self-pumping technique [14], and automatic gain controlled erbium-doped fiber amplifier using spontaneous emission [15] etc. However, it is prominent that these systems suffer from less Gain, high Gain fluctuations, complexity and high cost.

In this work, a Long band erbium doped fiber amplifier is proposed with high gain 34.12 ± 0.405 dB by incorporating the three fiber bragg gratings (FBGs) for amplified spontaneous noise reinjection and Gain flatness enhancement.

2 Principle of operation

For the enhancement of Gain flatness, and Gain in long band erbium doped fiber amplifier, multiple fiber gratings (FBG1, FBG2) are incorporated to make Fabry-perot (F-P) lasing resonance cavity for the reflection of amplified spontaneous emission noise in forward and backward direction. Reflecting port's center frequency decides the lasing wavelength and also it is important to note that this wavelength acts as secondary pump source to L-band EDFA amplifier. L-band EDFA also gets additional pump (secondary pump) with external pump sources due to this wavelength which is present due to lasing resonance in F-P cavity structure. As discussed in [9], EDFA based on F-P controlled theory, Gain controlled is given as (closed form)

$$G(\lambda) = e^{\{[\alpha(\lambda)+g^*(\lambda)]\bar{n}-[\alpha(\lambda)+l(\lambda)]\}L}$$

L is the length of EDF, wavelength of signal is λ , g^* , l and α are emission coefficient, background loss and absorption coefficient of erbium doped fiber respectively. Population inversion (average) is $\bar{n} = \left(\frac{1}{L}\right) \int_0^L n(z)dz$ over the lasing cavity.

Lasing conditions directly derive population inversion (average) in laser controlled erbium doped amplifier. This is derived even without knowledge of distribution of actual optical power along cavity length. Effective cavity loss in F-P configuration is expressed as

$$L_c = \frac{(-10 \log \sqrt{r_1 r_2} + \delta_c)}{L}$$

Reflectivity r_1 and r_2 are of the fiber bragg gratings, accumulated insertion losses of FBGs and splices is represented by δ_c . r_1 and r_2 as well as δ_c are the major effective cavity loss deciding factors. Average population inversion is expressed as [9]

$$\bar{n} = \frac{\alpha(\lambda_B) + l(\lambda_B)}{\alpha(\lambda_B) + g^*(\lambda_B)} + \frac{L_c}{4.34\gamma[\alpha(\lambda_B) + g^*(\lambda_B)]}$$

Center wavelength (reflected) of FBG is λ_B , for F-P configuration γ is 2 [9]. Effective cavity loss's (L_c) function is \bar{n} , where λ_B is pump wavelength independent.

In laser controlled F-P configuration EDFA, there are two effects encountered in L band such as low population inversion and strong ASE noise due to lasing oscillation of fiber bragg gratings. Low population inversion gives rise to issues like high noise figure and a low gain flatness. For effective gain control, longer lasing wavelengths are needed and lower cavity losses are also required. But to lower the noise figure and to increase gain flatness, shorter lasing wavelengths as well as high cavity losses are appropriate but decrease the gain significantly [9]. Therefore, a trade off is there between gain flatness, gain and noise figure.

Amplifiers spontaneous emission is significant effect in L-band controlled F-P lasers in which FBGs are employed. In L-band EDFAs, C-band ASE noise occurs due to 980 nm pump. Strong ASE emerges due to long length of EDF and pump due to transition energy levels of ${}^4I_{13/2}$ and ${}^4I_{15/2}$ energy levels. ASE at 1533 nm act as extra pump (secondary pump) due to lasing signal. Combination of ASE signal and external pump enhance L-band EDFA performance in terms of Gain flattening, Gain and noise figure. Also it is evident that pump at 980 nm is better for L-band EDFA as compared to 1480 nm for getting high Gain and larger population inversion.

In this study, it is perceived that pumping employing 980 nm to L-band EDFA generate ASE in C-band as shown in Figure 2 and when this ASE is fed to L-band EDFA again as additional pump, it further introduce a ASE effect in L-band as shown in Figure 3 which is important to increase Gain and population inversion. A wavelength of 1565 nm at which ASE is observed in this work after injecting C-band ASE to co-propagating direction with wavelength division multiplexed channels. A novel design is represented by incorporating third FBG after WDM multiplexer and utmost goal of this FBG is to help the system for attaining enhanced Gain flatness. Basic function of this FBG is to attenuate the WDM

signals prior to the insertion into L-band EDFA so that output amplitude different of WDM channels decreases. Overall gain is given as

$$G(\lambda_{WDM}) = e^{\{[\alpha(\lambda_{WDM})+g^*(\lambda_{WDM})]\bar{n}-[\alpha(\lambda_{WDM})+l(\lambda_{WDM})+A_s(\lambda_{WDM})]\}L}$$

L is the length of EDF, WDM wavelengths are λ_{WDM} , g^* , l and α are emission coefficient, background loss and absorption coefficient of erbium doped fiber respectively. A_s is the attenuation introduced by third FBG to specific wavelengths grid for attaining better Gain flatness. Figure 1 depicts the Er^{3+} diagram and also function of FBGs for optimized Gain and Gain flatness.

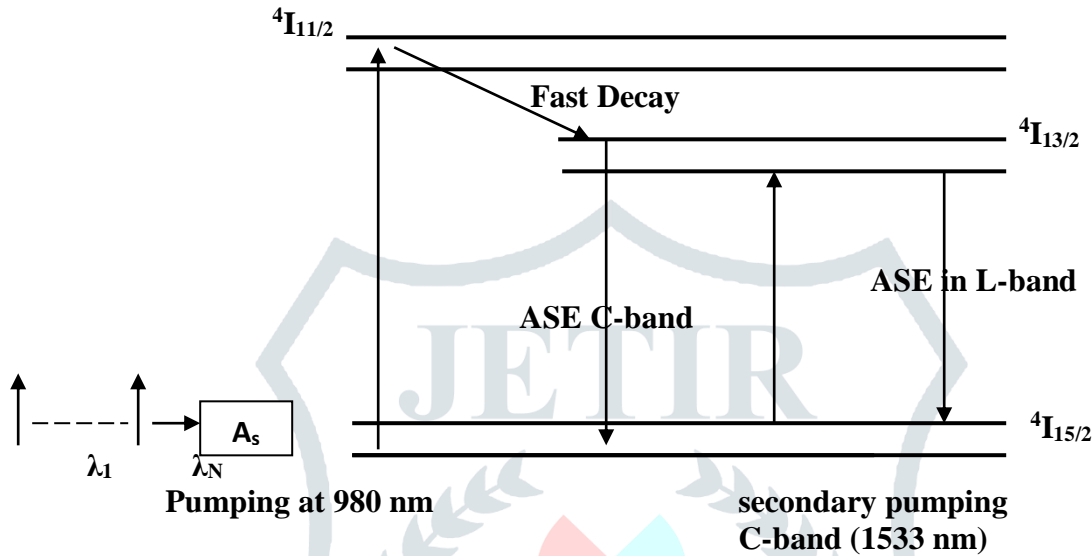

Figure 1 Principle of L-band EDFA ASE induced system employing FBGs (Er^{3+} energy diagram)

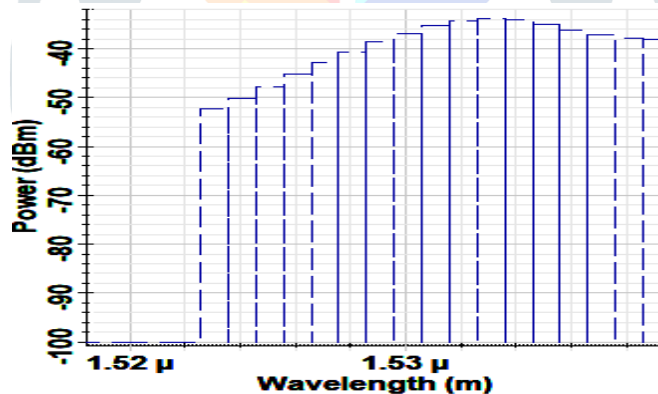

Figure 2 ASE emerged at 1533 nm and FBG1 reflected spectrum when 980 nm primary pump fed to L-band EDFA

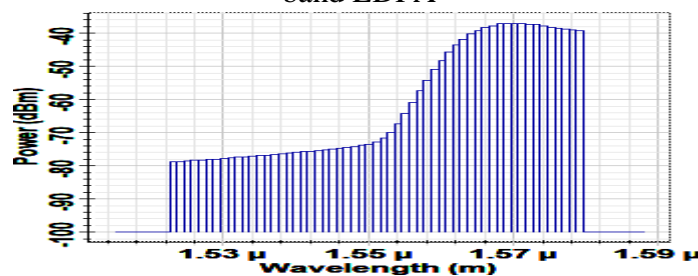

Figure 3 FBG2 reflected spectrum due to L-band EDFA maximum ASE emergence at 1565 nm

2 System setup

In this work, a bidirectionally pumped long band erbium doped fiber amplifiers is proposed using two fiber bragg gratings with amplified spontaneous reinjection and third FBG is incorporated to enhance Gain flatness in WDM system as depicted in Figure 4.

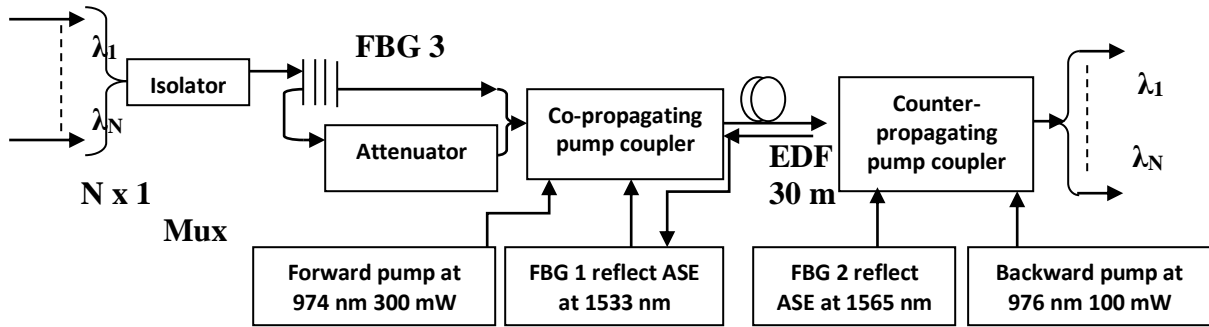

Figure 4 Proposed system setup

Speed of the operation is fixed to 10 Gbps from binary data bits generator. A continuous wave laser at ultra low power (-50 dBm) power and wavelength grid of L-band is incorporated in the system. Ultra dense frequency spacings (25 GHz) are also fed between WDM channels. Each transmitter consists of binary bit generator, non-return to zero, laser source and intensity modulator. All channels (16, 32) are multiplexed and passed through optical isolator to prevent optical sources from the back flowing optical intensity due to ASE. FBG 1 is placed after multiplexer to provide attenuation of 1.5 dB to specific grid of wavelengths which will be amplified more in EDFA as shown in Figure 5. Combination of reflected and transmitted WDM signals fed to optical co-propagating pump coupler and a pump 1 at 974 nm wavelength is also coupled to this module. Here, FBG 2 is acting as the reflector of backscattered ASE signal at 1533 nm and combined with pump 1.

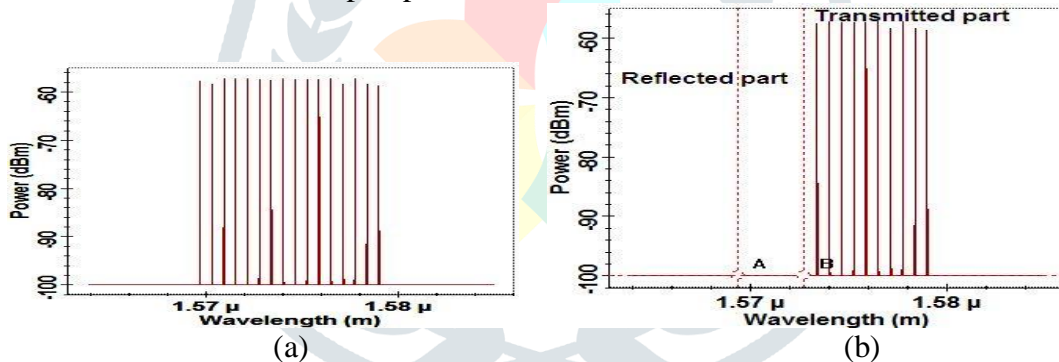

Figure 5 Optical spectrum of L-band wavelengths after (a) WDM (b) after FBG 1

We have chosen the 1533 nm wavelength to be reflected because of maximum intensity at this point. An erbium doped fiber with 200 ms metastable lifetime is taken. Various physical parameters are varied such as core radius, input power, doping radius and length of the EDF. Simulation parameters are shown in Table 1 to clear the factors that are considered for the proposed work.

Table 1: Simulation parameters of the demonstrated work

Parameters	Values
Lasers	Tunable laser source
WDM channels and power	16, 32 and -50 dBm
Data speed	10 Gbps
FBGs used	3
Number of FBGs to reinject ASE	2
Length of EDF fiber	varied from 5m to 35 m
Core radius of EDF	varied from 0.7 um to 1.9 um
Input power	varied from -55 dBm to 5 dBm

Er ion density	1.9e+025 m ⁻³
Numerical aperture	0.4

Output of EDF fiber send to the counter propagating coupler and power of pump 2 at wavelength 976 nm is combined here. FBG 3 is employed to reflect the forward scattered amplified spontaneous noise and power is combined with pump 2. Finally signal passed through the isolator and gain of signal is accessed by dual port WDM analyzer.

Results and discussions

In this research work, we emphasized on the Gain enhancement, Gain flattening of the long band erbium doped amplifier with the use of amplified spontaneous emission in C-band and L-band reinjection through FBGs. To accomplish the work, Optiwave optisystem is considered. Effect of various physical parameters of erbium doped fiber such as radius of core, length of the EDF fiber, launched power, forward/backward ASE power emergence are investigated in terms of Gain, noise figure. First and foremost, effect of launched power is analyzed on L-band EDFA. Tunable lasers at L-band (1575.89 – 1579 nm) wavelengths are incorporated in the system with 10 MHz laser linewidth. Power is varied from -55 dBm to 5 dBm and iterated in the EDF fiber which connected with bidirectional pumping. Results are analyzed in terms of output power and readings are noted from wavelength division multiplexed analyzer. Figure 6 depicts the performance of the system at varied levels of input power levels in terms of Gain and noise figure. Results revealed that there is increase in output power from -55 dBm to -45 dBm and it starts decreasing beyond -45 dBm. This is due to the less emergence of ASE on high power levels and saturation of the amplifier. Highest Gain value of $34.13 \text{ dB} \pm 0.45$ is achieved at input power level of -55 dBm with noise figure of 7.20 dB. Moreover, in case of noise figure, the power of the noise is approximately similar at all power levels except the 5 dBm. So, it is recommended to use -55 dBm due to highest Gain and acceptable level of noise figure. It is also observed that at -25 dBm maximum Gain flatness $\pm 0.15 \text{ dB}$ has been seen but maximum Gain reduces to 31.57 dB.

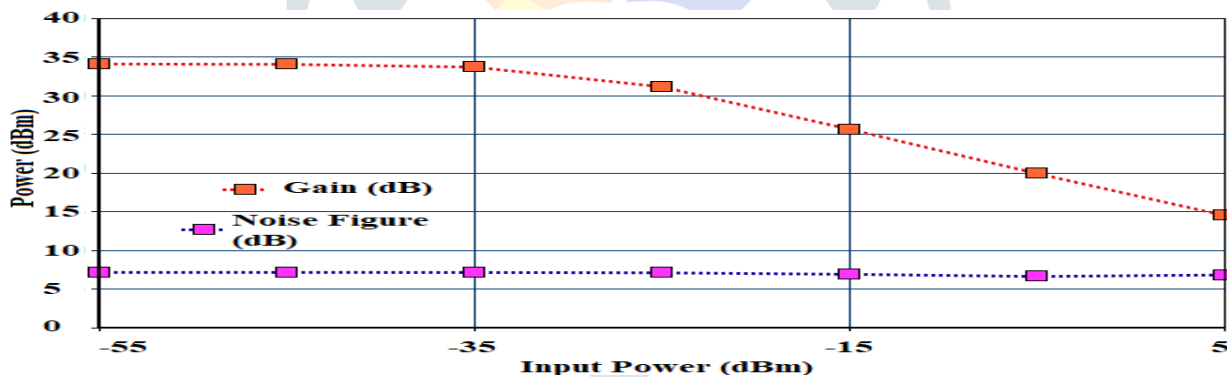

Figure 6 Variation of Gain and noise figure of proposed L-band EDFA with respect to input power

Amplified spontaneous emission noise is a prominent power degrading issue in the erbium doped fiber amplifiers. However, in this work, the use of ASE has been done to enhance the Gain through the FBGs. This is done by re-injecting the ASE in the EDF fiber with the combined power of pumps. It is seen that there are two type of ASEs in the system. One is forward ASE and second is backward ASE. Figure 2 represents the output of optical spectrum analyzer to depict the backward/forward ASE. It is perceived from Figure 2 that maximum backward ASE is emerged at the wavelength of 1533 nm (C-band) and in Figure 3, the maximum forward noted ASE is near about 1565 nm (L-band). Thus, in proposed work, both C/L band ASEs at 1533 nm (backward) and 1565 nm (forward) are re-injected through the two FBGs (2 and 3) in the EDF fiber.

Figure 7 depicts the representation of forward ASE and backward ASE at different input powers. It is interesting to observe the increase in launched power cause reduction in the forward ASEs (1565 nm) but backward (C-band) ASE increases as the input power increases. Power level of backward ASE is greater

than the forward ASE at every level of incident light. ASEs of both bands are almost near from -55 dBm to -35 dBm input power but beyond these values backward ASE abruptly increases and forward ASE falls. Lowest and highest level of ASE is observed at power of 5 dBm for forward and backward ASE emergence respectively.

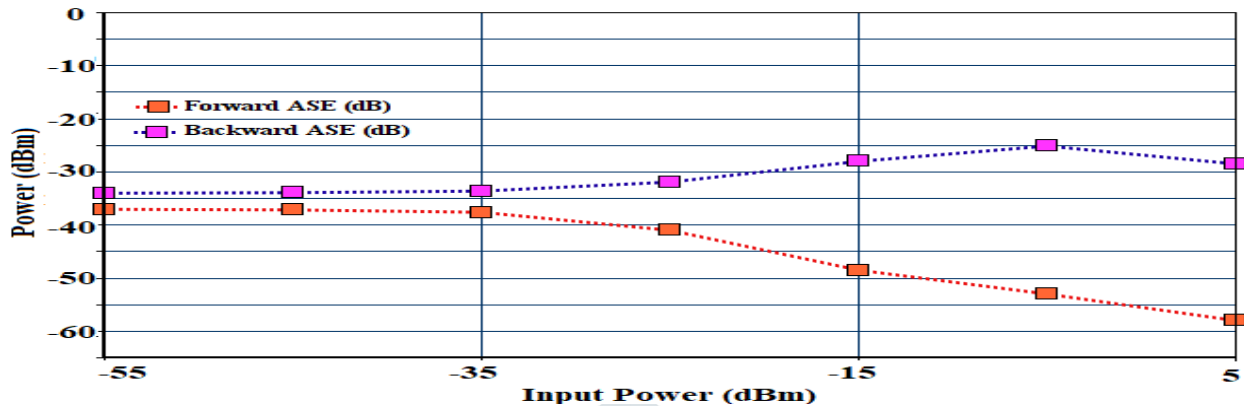

Figure 7 Graphical representations of forward ASE and backward ASE at different input powers

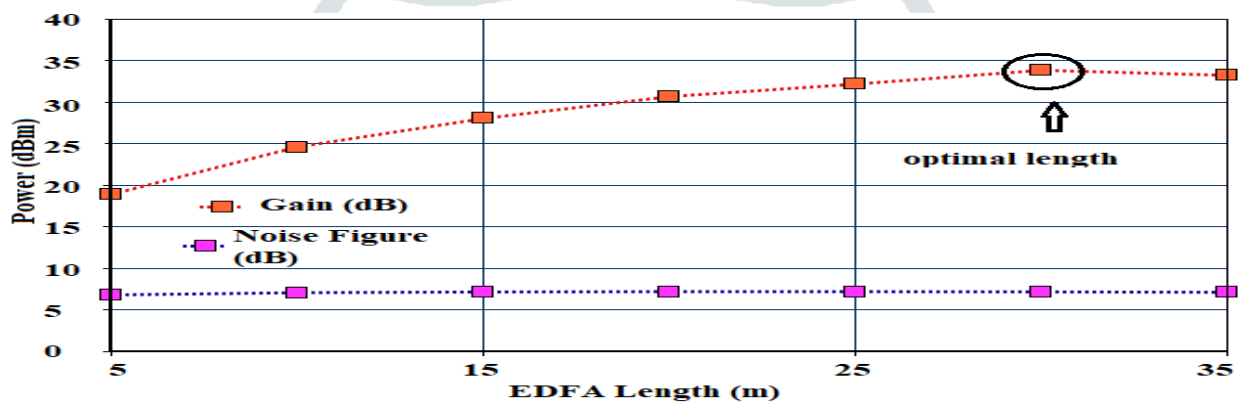

Figure 8 Effect of EDF lengths on Gain and noise figure of proposed L-band EDFA

Figure 8 represents the effect of changing the length of the erbium doped fiber on the Gain and noise figure. EDF length has a significant effect on the overall gain of the system and it is reported that longer lengths cause more output power and inturn increase the Gain of the system. In our proposed work, the length of the EDF tends to fluctuate between 5 m to 35 m and Gain is noted down on these values. It is observed that the highest Gain (34.12 dB) is seen at the length of 30 m and value of noise figure at this point is 7.20 dB. All the values of the Gains and noise figures according to the different lengths of the erbium doped fiber. It is recommended to use 30 m length of EDF for maximum Gain.

Further, a performance comparison has been carried out for different values of core radius. Core radius is varied from 0.7 micron meter to 1.9 micron meter of erbium doped fiber to check the gain and noise figure. From the Figure 9, it is perceived that the at the initial small core radius values (0.7 – 1.1 μm), Gain tends to increase and after 1.1 μm it starts decreasing. Highest Gain is found at the core radius value of 1.1 μm.

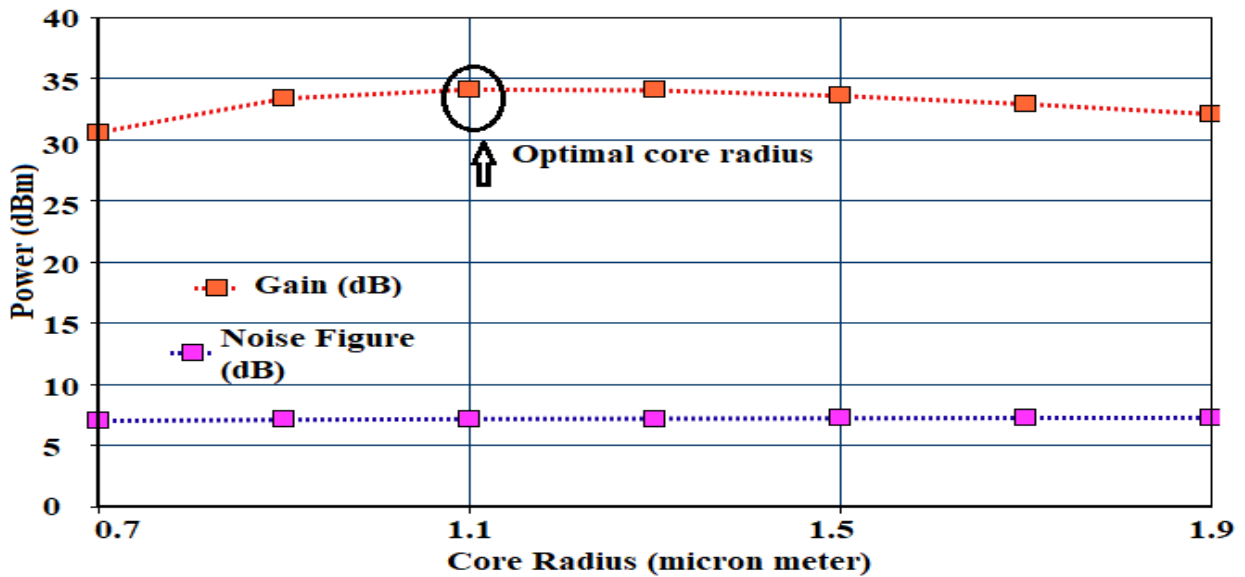

Figure 9 EDF’s core radius effects on ASE re-injected L-band EDFA in terms of Gain and noise figure

Numerical aperture of the fiber also varies with the change in the core radius. Enhanced value of Gain with acceptable noise figure is reported at the 1.1 μm and thus recommended to use this core radius. From the aforementioned performed evaluations and results, it is observed that the optimal length of erbium doped fiber is 30 m with the launched power of -55 dBm. Also the core radius should be considered 1.1 micron meter.

Figure 10 represents the L-band EDFA Gain with and without dual C/L band ASE re-injection. Also comparison of noise figure is also represented and it is perceived that there is maximum Gain of 34.12 dB in case of ASE reinjection and 31.26 dB when no ASE is employed. Noise figure of 7.20 dB and 8.12 dB is observed in case of ASE re-injected and without re-injection system respectively.

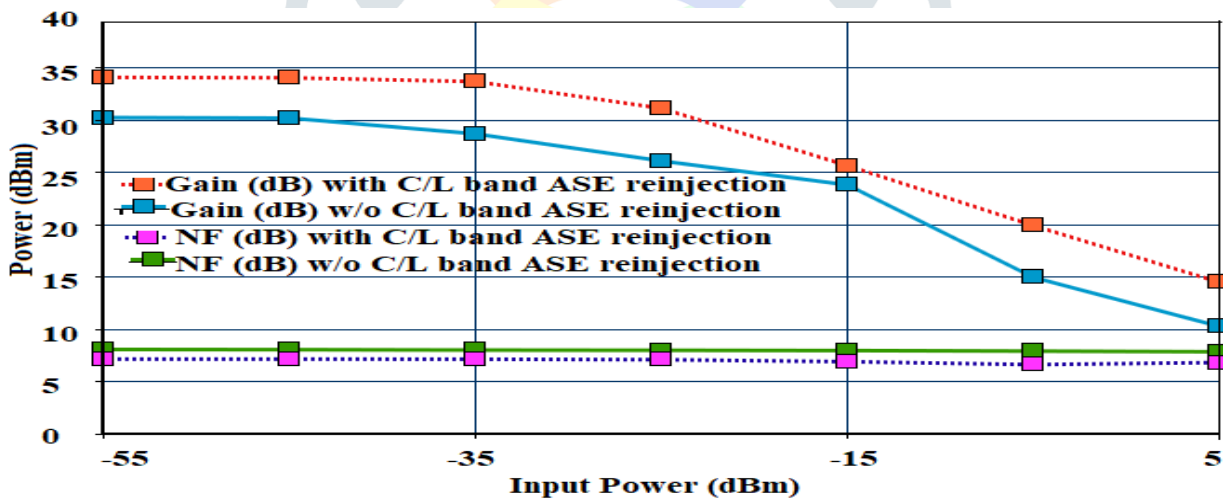

Figure 10 Comparison of Gain and noise figure in with and without C/L ASE re-injected L-band EDFA

(THz)		(dB)	
Frequency	Gain (dB)	Noise Figure	
189.862	33.732376	7.2036	
189.887	33.697842	7.23756	
189.912	33.669209	7.50087	
189.937	33.693543	7.47597	
189.962	33.706444	7.46249	
189.987	33.72857	7.4398	
190.012	33.840635	7.32716	
190.037	33.921923	7.38965	
190.062	33.891411	7.41959	
190.087	33.914083	7.39635	
190.112	34.000617	7.30924	
190.137	34.014392	7.2949	
190.162	33.9645	7.60951	
190.187	33.924669	7.64877	
190.212	33.987461	7.5854	
190.237	34.126655	7.44564	

Gain (dB)	
Min value	33.669209
Max Value	34.126655
Total	33.865629
Ratio max/min	0.45744544
(THz)	
Gain flatness	

Figure 11 Representation of Gain and noise figure of 16-WDM channels

Multiple channels such as 16 and 32 WDM channels with 25 GHz ultra dense channel spacing are investigated in terms of Gain and noise figure. Gain and noise figures are approximately similar in 16 and 32 channels however there is difference in Gain flatness and values are ± 0.45 dB as shown in Figure 11 and ± 1.14 dB respectively.

Conclusion

In this work, the effect of different physical parameters of the erbium doped fiber amplifier on the L-band wavelengths of WDM system (16, 32 channels) has been studied by incorporating the dual C/L band amplified spontaneous emission noise re-injection through the cost effective FBGs. With the incorporation of the three FBGs in the system, there is significant increase in the values of the Gain and also enhancement in Gain flatness. Maximum Gain is achieved at the input power level of -55 dBm and the maximum ASE is emerged at 1533 nm (backward) and 1565 nm (forward). Further, core radius, erbium doped fiber length is varied along with the input power to examine their effects on the Gain of the system. It is perceived that the input power of -55 dBm, core radius of 1.1 μ m and EDF length of 30 m provides the maximum Gain of 34.12 dB with the noise figure of 7.20 dB and thus, is considered as the optimal parameters. Gain Flatness of ± 0.45 dB in case of 16 channels and ± 1.41 in case of 32 channels is observed. To the best of author’s knowledge, no work has been demonstrated yet on ultra low input power (-55 dB), ultra dense (25 GHz), 16, 32 channels WDM system which provide high Gain (34.12 dB) and enhanced Gain flatness (± 0.45 dB) like our proposed system in cost effective way by utilizing FBGs as well as ASEs in L-band EDFA system.

References

- [1] S.W. Harun, T. Subramaniam, N. Tamchek, H. Ahmad, “Gain and noise figure performances of L-band EDFA with an injection of C-band ASE”, *J. Teknol.*, vol. 40, pp. 9-16, 2004.
- [2] N. Singh, M. Kumar, A. Verma, “Automatic Gain-Controlled HOA with Residual Pumping”, *Journal of optical communications*, <https://doi.org/10.1515/joc-2017-0185>, 2017.
- [3] A. Altuncu, A. Başgümüş, “Gain enhancement in L band loop EDFA through C band signal injection”, *IEEE Photonics Technol. Lett.*, vol. 17, pp. 1402–1404, 2005.
- [4] J. Yang, X. Meng, C. Liu, “Accurately control and flatten gain spectrum of L-band erbium doped fiber amplifier based on suitable gain-clamping”, *Opt. Laser Technol.*, vol. 78, pp. 74–78, 2016.
- [5] H. Chen, M. Leblanc, G.W. Schinn, “Gain enhanced L-band optical fiber amplifiers and tunable fiber lasers with erbium doped fibers”, *Opt. Commun.*, vol. 216, pp. 119–125, 2003.
- [6] M.S. Zainudin, N.A.M.A. Hambali, G.C. Seong, M.S.A. Hurera, N. Roshidah, M.H.A. Wahid, M.M. Shahimin, A.Z. Malek, “Comparative characteristics between L-Band EDFA, L-Band EDFA utilizing single FBG and dual stage L-Band EDFA utilizing dual FBG configurations”, *Appl. Mech. Mater.*, vol. 815, pp. 348–352, 2015.
- [7] P. Myslinski, D. Nguyen, J. Chrostowski, “Effects of concentration on the performance of erbium-doped fiber amplifiers”, *Journal of Lightwave Technology*, vol. 15, pp. 112-120, 1997.
- [8] Y. Zhang, X. Liu, J. Peng, W. Zhang, “Wavelength and power dependence of injected C-band laser on pump conversion efficiency of L-band EDFA”, *IEEE Photonics tech. letters*, vol. 14, pp. 290-292, 2002.
- [9] F. E. Durak, A. Altuncu, “The effect of ASE reinjection configuration through FBGs on the gain and noise figure performance of L-Band EDFA”, *Optics communications*, vol. 386, pp. 31-36, 2017.
- [10] C.L. Chang, L. Wang, “Y.J. Chiang, A dual pumped double-pass L-band EDFA with high gain and low noise”, *Opt. Commun.*, vol. 267, pp. 108–112, 2006.
- [11] Seongtaek Hwang, Kyuman Cho, “Gain Tilt Control of L-Band Erbium-Doped Fiber Amplifier by Using a 1550-nm Band Light Injection”, *IEEE photonics technology letters*, vol. 13, no. 10, 2001.
- [12] Jiuru Yang, Xiangyu Meng, Changxing Liu, and Chunyu Liua, “Gain-flattened two-stage L-band erbium-doped fiber amplifier by weak gain-clamped technique”, *Optical Engineering*, vol. 54, no. 3, 2015.
- [13] S. W. Harun, N. Tamchek, and H. Ahmad, “Gain and noise performances of an l-band EDFA utilizing a ring laser cavity with fiber bragg grating”, *Microwave and optical technology letters*, vol. 36, no. 1, 2003.
- [14] M.A. Mahdi and H. Ahmad, “A novel ASE self-pumping technique for gain-enhanced L-band erbium-doped fiber amplifiers”, *Optical Fiber Technology*, vol. 8, pp. 146-152, 2002.
- [15] Jyi-Lai Shen, Yueh-Chien Lee, and Chia-Chih Huang, “L-band automatic-gain-controlled erbium-doped fiber amplifier utilizing C-band backward-amplified spontaneous emission and electrical feedback monitor”, *Applied optics*, vol. 48, no. 5, 2009.