

# POWER MUYLIPLICATION USING FLYWHEEL TO PRODUCE ELECTRICITY

<sup>[1]</sup> S.Vamsi Krishna , <sup>[2]</sup>Kalva Charan Tej, <sup>[3]</sup> Naveen Reddy Pothula <sup>[4]</sup>B LAXMI NARASIMHA

<sup>[1]</sup>Assistant Professor, <sup>[2]</sup>Assistant Professor, <sup>[3]</sup>Assistant Professor, <sup>[4]</sup>Student [IV-Year Mechanical]

<sup>[1]</sup>sravs03@gmail.com <sup>[2]</sup>Charantej.kalva@gmail.com, <sup>[3]</sup>reddy.n52@gmail.com, ,

<sup>[4]</sup>[bogalaksminarasimha@gmail.com](mailto:bogalaksminarasimha@gmail.com)

**Abstract**— Electricity production using conventional methods consume lot of energy, utilize from the fuels and which in turn converted from one source of energy to another. To produce free energy experiments conducted on the perpetual motion states that it is practically impossible to run a machine on the perpetual motion 100 percent . Instead of pursuing on perpetual motion, when we support the perpetual motion with slight energy boost just before the halt their will be energy efficiency in certain existing electrical production systems. From the case study “POWER MULTIPLICATION BY FLYWHEEL” By Mr.changanti bhaskar Flywheel energy storage systems (FESS) employ kinetic energy stored in a rotating mass with very low frictional losses. Electric energy input accelerates the mass to speed via an integrated motor-generator. The energy is discharged by drawing down the kinetic energy using the same motor-generator. This process of converting different types of energy is the modern way of producing power or electricity. Flywheel once reached certain RPM will continue motion because of inertia This paper deals with the concept of producing electrical energy using flywheel. So when we combine both above systems then there will be partial perpetual motion which produce electricity with the efficiency of almost 320 time the power or fuel consumed to produce the power.

**Index Terms**-- Electricity Generator, Flywheel, Perpetual Motion, Flywheel, Power Multiplication, Conventional Energy, Free Energy, Gravity Power System, Generator, vacuum, green power, Batteries

## I. INTRODUCTION

As we know the necessity of electricity, it very essential to invent new techniques for the power generation and it is better not to use the non-renewable resources like coal which we cannot retrieve back, releases harmful gases when it is burnt. Keeping all these in mind world has to come forward with new ways of power generation systems to make the environment green. So the alternative source of power generation methods should be introduced with very high efficiency. Here we all know that energy can not be created nor destroyed, but can be converted from one form to another.

Electricity can be generated by rotating the alternator or the motor generator. Energy utilized to rotate the motor generator will be different in different systems.

## II. METHODOLOGY

### A. Electricity Generation:

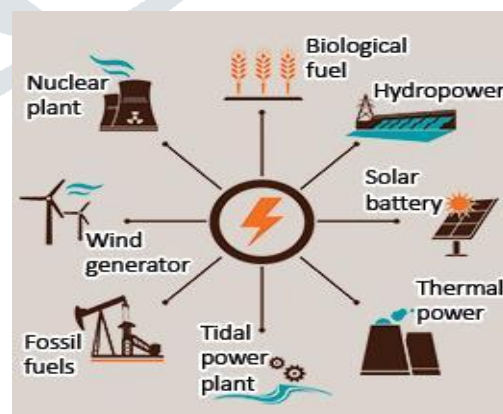

Fig. 1

### B. Flywheel Energy Storage system:

Flywheel energy storage (FES) works by accelerating a rotor (flywheel) to a very high speed and maintaining the energy in the system as rotational energy. When energy is extracted from the system, the flywheel's rotational speed is reduced as a consequence of the principle of conservation of energy adding energy to the system correspondingly results in an increase in the speed of the flywheel. Most FES systems use electricity to accelerate and decelerate the flywheel, but devices that directly use mechanical energy are being developed. Advanced FES systems have rotors made of high strength carbon-fiber composites, suspended by magnetic bearings, and spinning at speeds from 20,000 to over 50,000 rpm in a vacuum enclosure. Such flywheels can come up to speed in a matter of minutes reaching their energy capacity much more quickly than some other forms of storage.

### Generation 4 Flywheel

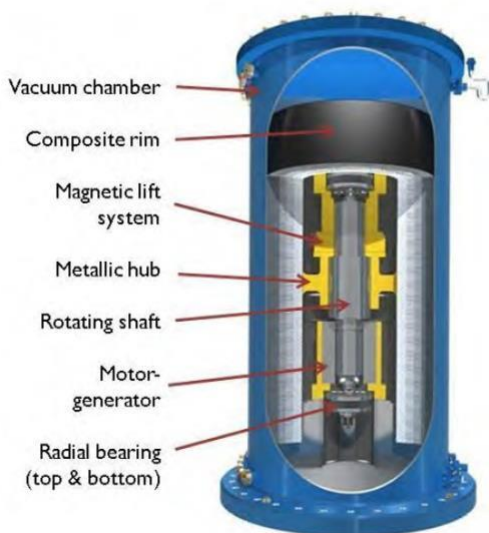

Fig.2

### C. Working Principle:

Flywheel kinetic energy (Inertia) will be converted to mechanical energy and the mechanical energy will be converted to electrical energy by using a Motor generator, electricity will be produced. And the power will be obtained in dc.

### D. Working:

This generator consists of Flywheel energy storage system (FESS) with slight modification like, instead of using it for the power back up system as utilized in satellites by NASA, we use to generate continues flow of electricity unto the inertia of the flywheel. Larger the Flywheel greater the kinetic energy and generation of electricity is high and efficient. This flywheel is connected to Motor generators on both sides. One is to rotate it to its full potential and another is to take the mechanical energy from the flywheel to produce electricity.

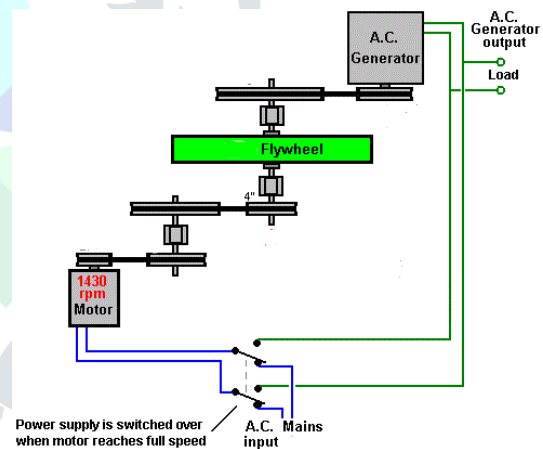

Fig. 3

### E. Magnetic Levitation:

Magnetic levitation, maglev, or magnetic suspension is a method by which an object is suspended with no support other than magnetic fields. Magnetic force is used to counteract the effects of the gravitational acceleration and any

other accelerations. The two primary issues involved in magnetic levitation are lifting forces: providing an upward force sufficient to counteract gravity, and stability: ensuring that the system does not spontaneously slide or flip into a configuration where the lift is neutralized. Magnetic levitation is used for maglev trains, contactless melting, magnetic bearings and for product display purposes.

## CONCLUSION

With replacement of the conventional ball bearings in the FESS the fly wheel will be able to store more energy and more efficient the system will be. World begin to consume lot of energy than it is essentially required, so high efficient

power generation systems are required to balance the demand for the electricity. Indirectly the consumption of non-renewable sources will be reduced and low pollution etc.

## REFERENCES

- [1] L. Zhou and Z. Qi, —Review of Flywheel Energy Storage System, Proceedings of ISES Solar World Congress 2007, Beijing, China, Sept. 2007, pp.2815-2819.
- [2] H. Ibrahim, A. Ilinca, and J. Perron, —Energy Storage Systems—Characteristics and Comparisons, J. of Renewable and Sustainable Energy Reviews,
- [3] Filatov and E. Maslen, “Passive magnetic bearing for flywheel energy storage systems”, IEEE Trans. Magn., vol. 37, No. 6, pp. 3913-3924, 2001

