

# Fault Monitoring and Protection of Three Phase Load

Pratik paradkar<sup>1</sup>, Saurabh shahu<sup>2</sup>, Ishwer kolhe<sup>3</sup>, Vaibhav Kayarkar<sup>4</sup>, Dipak Wyzode<sup>5</sup>, Prof.Anurag Ukande<sup>6</sup>

<sup>1,2,3,4,5</sup>Student Suryodaya collage of Engineering and Technology, Nagpur  
Prof ,Department of Electrical Engineering, Suryodaya collage of Engineering and Technology,Nagpur.

## ABSTRACT

In our paper protection of three phase induction motor or any three phase devices Protection of three phase operating devices against overvoltage, overload, over temperature, and under voltage, occurring in the course of its operation is very important, because it is used intensively in industry for various purposes. Three phase operating devices can be protected using some components, such as timers, contactors, voltage, and current relays. This classical method involves mechanical dynamic parts. Computer and microcontrollers based protection methods have eliminated most of the mechanical components. We are introducing accurate monitoring of the parameter and protecting the load from undesired values of the parameter. We are also providing self-diagnosis. If the parameter recovers then system will auto reset itself? Moreover, the voltages, currents, speed, and temperature values of the device, and the problems occurred in the system, are monitored and warning messages are shown on the computer screen. In our paper we are going to monitor and control the load using single controller with various faults measuring techniques related to the three phase power. We will also give a provision to auto reset the system after faults restores.

**Keywords:** PIC16F886 microcontroller, faults, overtemperature, singlephasing, monitoring, overvoltage, undervoltage, earth fault.

## INTRODUCTION

Protection of three phase operating devices against overvoltage, overload, over temperature, and under voltage, occurring in the course of its operation is very important, because it is used intensively in industry for various purposes. Three phase operating devices can be protected using some components, such as timers, contactors, voltage, and current relays. This classical method involves mechanical dynamic parts. Computer and microcontrollers based protection methods have eliminated most of the mechanical components. We are introducing accurate monitoring of the parameter and protecting the load from undesired values of the parameter. We are also providing self-diagnosis. If the parameter recovers then system will auto reset itself?

Moreover, the voltages, currents, speed, and temperature values of the device, and the problems occurred in the system, are monitored and warning messages are shown on the computer screen. Microcontroller had developed less cost, provides higher accuracy as well as safe and visual environment. The three phase devices experiences several types of electrical faults like over/under voltage, over load, open circuit, unbalanced voltage, and single phasing and earth fault. Currently independent systems and controllers are used to monitor and control the load, which results a heavy power consumption and installation space. In our paper we are going to monitor and control the load using single controller with various faults measuring techniques related to the three phase power. We will also give a provision to auto reset the system after faults restores.

## METHODOLOGY FOLLOWED

### Block diagram:

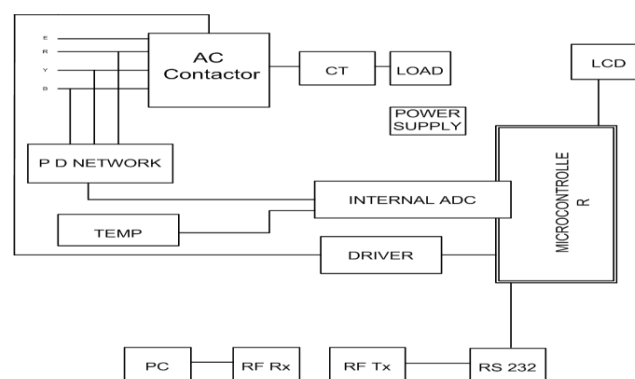

Figure: -Block Diagram of Project COMPONENTS :

## Step Down Transformer

The transformer is one of the simplest of electrical devices. Its basic design, material, and principles have changed little over the last one hundred year, yet transformer design and material continue to be improved. Transformers are essential in high voltage power transmission providing an economical means of transmitting power over large distances.

## Voltage Regulator 7805

Features, Output current up to 1A , Output voltage of 5,6,8,9,10,12,15,18,24v, Thermal overload protection Short circuit protection, Output transistor safe operating area protection

## Rectifier

A rectifier is an electrical device that converts alternating current (AC), which periodically reverses direction, to direct current (DC), current that flows in only one direction, a process known as rectification. Rectifier has many uses including as components of power supplies and as detectors of radio signals. Rectifier may be made of solid state diodes, vacuum tube diode, mercury arc valve, and other components.

## Filter

Capacitive filter is used in this project. It removes the ripples from the output of rectifier and smooth the D.C. Output received from this filter is constant until the Main voltage and load is maintained constant. However, if either of the two is varied D. C. voltage received at this point changes. Therefore a regulator is applied at the output stage.

## Transistor

A transistor is a semiconductor device used to amplify and switch electronic signals. It is made of a solid piece of semiconductor material, with at least three terminals for connection to an external circuit. A voltage or current applied to one pair of the transistor's terminal changes the current flowing through another pair of terminal. Because the controlled (output) power can be much more than the controlling (input) power, the transistor provides amplification of a signal. Today, some transistors are packaged individually, but many more are found embedded in integrated circuits.

## LED

LED are semiconductor device. Like transistor, and other diodes, LED is made out of silicon. LEDs are based on the semiconductor diode. When the diode is forward biased (switched on), electron are able to recombine with holes and energy is released in the form of light. This effect is called electroluminescence and the color of the light is determined by energy gap of the semiconductor.

## LM35

The LM35 series are precision integrated-circuit temperature device with an output voltage linearly – proportional to the Centigrade temperature, the LM35 device has an advantage over linear temperature sensors calibrated in Kelvin, as the user is not required to subtract a large constant voltage from the output to obtain convenient centigrade scaling. The LM35 device does not require any external calibration or trimming to provide typical accuracies of  $\frac{1}{4}^{\circ}\text{C}$  at room temperature and  $\frac{3}{4}^{\circ}\text{C}$  over a full  $-55^{\circ}\text{C}$  to  $150^{\circ}\text{C}$  temperature range. Lower cost is assured by trimming and calibration at the wafer level. The low-output impedance, linear output and precise inherent calibration of the LM35 device makes interfacing to readout or control circuitry especially easy. The device is used with single power supplies, or with plus and minus supplies. The LM35 device draws only 60  $\mu\text{A}$  from the supply, it has very low self-heating of less than  $0.1^{\circ}\text{C}$  in still air.

## Resistors

A resistor is a two-terminal electronic component designed to oppose an electric current by producing a voltage drop between its terminals in proportion to the current, that is, in reactance with ohm's law

$$V = IR$$

## CAPACITOR

A capacitor or condenser is a passive electronic components consisting of a pair of conductors are separated by a dielectric. When a voltage potential difference exists between the conductors, an electric field is present in the dielectric. This field stores energy and produces a mechanical force between the plates. The effect is greatest between wide, flat, parallel, separated conductors.

### Relay

An electromagnetic switch, consist of a coil, 1 common terminal, 1 normally closed terminal, and one normally open terminal. When the coil of an SPDT relay is at rest, the common terminal and the normally closed terminal have continuity. When the coil is energized, the common terminal and the normally open terminal have continuity.

### Potential transformer

It is a potential transducer to monitor voltages of three phases. Potential transducer is used for converting the higher value of the main supply to lower value that can be determined by the PIC controller.

### LCD display

LCD stands for Liquid Crystal Display. LCD is finding wide spread use replacing LEDs(seven segment LEDs or other multi segment LEDs) because of the following reasons:The declining prices of LCDs. The ability to display numbers, characters and graphics.

### Working:

The three phase supply is applied to this device. This three phase supply is going to the step down transformer and potential transformer. The step down transformer is converted this three phase supply into 12v that is 440v into 12v .This 12v supply is going to the resister the resister convert this 12v supply into 5v. The rectifier converts AC input into its equivalent DC output. The 5v supply is going to the microcontroller but this 5v supply is not pure dc then we can connect filter then the filter remove the ripple and noise. The capacitor improves the power factor of this device. The 12v supply is going to the relay and the relay is operated.

### There are 4 fault identify from this system

- 1.Open circuit and short circuit
- 2.Over voltage and under voltage
- 3.Temperature fault
- 4.Earth fault

In open circuit fault the supply is open then the load is trip and in short circuit fault the any supply is short circuited then the load is trip. In over voltage fault the incoming supply is above 280V then the load is trip and in under voltage fault the incoming supply is below 180V then the load will be trip. In temperature fault we kept temperature 100<sup>0</sup>c the motor heat up above the 100<sup>0</sup>c then the motor will be trip. In earth fault the earth fault generate naturally so the earth fault is coming so motor will be trip. In three phase fault the any phase is shorted or open then the motor will be trip.

### Advantage

- 1.Single Microcontroller.
- 2.Power consumption is low.
- 3.Use for all three phase devices.
- 4.Self-monitoring.
- 5.Self-diagnosis.
- 6.Auto Reset.

### Application

- 1.It is used in industry.
- 2.It is used in colleges.
- 3.It is used in hospital.
- 4.It is used in factory.

### Conclusion

Due to daily increased load of power system it is important to maintain system Reliability .As transformer plays important role in power system by maintaining reliability it is important that we should keep transformer from daily fault

occurring in it just by observing its key parameter so that such fault cannot result in bigger failure also apart from these sharing of data information is also essential using new technology at reduced cost. System to expert systems can be used to achieve all the parameters test and analysis of automation every system is automated in order to face new challenges in the present day situation. Automated systems have less manual operations, so that the flexibility, reliabilities are high and accurate. Hence every field prefers automated control systems. Especially in the field of electronics automated systems are doing better performance.

## FUTURE SCOPES

System can be monitored using internet using LAN & WAN connectivity Various Systems Can be Monitored Using Single module More than 1 system can be monitored using single monitoring module

## REFERANCES

- IEEE Transactions on Energy Conversion 10/2008; 23(3-23):734 - 741. DOI:10.1109/TEC.2008.921558 · 3.35 Impact Factor
- M.Sudha and P. Anbalagan, 2009.A Protection Scheme for Three Phase Induction-Motor from Incipient Fault Using Embedded Microcontroller Asian Journal of Scientific Research, 2: 28-50
- Energy conservation and management Volume 48, issue 3, March 2007
- “Online Off-Site Condition Monitoring Of Three Phase Induction Motor by Using GSM Technology”, N. B. Sheikh, Prof. S. S Duhamel, S. S. Hade, K. P.Varade, (ISSN 2250-2459, ISO 9001:2008 Certified Journal, Volume 3, Issue 4, April 2013)
- GSM based Distribution Transformer Monitoring System, Ashman Sharma (109EE0305), RajeshBehura (109EE0260), Department of Electrical Engineering, National Institute of Technology Rourkela