

Design of monitoring system for fault diagnosis in vehicles

Shivam Sudarshan Verma

Assistant Professor

School of Mechanical Engineering Lovely

Professional University

Phagwara, Punjab

Abstract

Nowadays, the numbers of accident are so high and uncertain. Accident can occur anytime and anywhere and can cause worst damage, serious injury and even death. These accidents are mostly cause by delay of the driver to hit the brake. As per the report by WHO about 1.3 million people dies each year in a road accident. Apart from it, about 30 million people suffer non-fatal injuries, with many incurring a disability as a result of their injury. In this project a system is proposed in for monitoring the various parameters and with proper actuators for the reduction of accidents. The proposed system will allow operator to monitor vehicle parameters such as RPM, diagnose and prevent fault. Apart from it is incorporated with Automatic Braking System which can eliminate operator failure by applying brake automatically if any obstacle comes in range. Thus, it will ensure the safety as well.

1. Introduction

Vehicle is wonderful machine, one of the engineering marvelous. At the same time a complex machine to handle having a lot of components, sometimes makes it difficult very difficult to handle and diagnose fault if occurs in vehicle. Nowadays, the numbers of accident are so high and uncertain. Accident can occur anytime and anywhere and can cause worst damage, serious injury and even death. These accidents are mostly cause by delay of the driver to hit the brake. As per the report by WHO about 1.3 million people dies each year in a road accident. Apart from it, about 30 million people suffer non-fatal injuries, with many incurring a disability as a result of their injury.

The proposed system will allow operator to monitor vehicle parameters such as RPM, diagnose and prevent fault. Apart from it is incorporated with Automatic Braking System which can eliminate operator failure by applying brake automatically if any obstacle comes in range. Thus, it will ensure the safety as well.

2. Objective

The main objective of the system is to prevent accidents. Most of the accidents in vehicles is due to delay in braking or sometimes due to driver's negligence. The system is incorporated with automatic braking system will prevent accidents by automatically applying the brake.

Moreover, it can also detect temperature of engine oil so that it can prevent any fault due increased engine oil temperature and also to ensure safety.

The proposed system will allow operator to monitor vehicle parameters, diagnose and prevent fault. Thus, it will help operator to know the state of vehicle and ensure safety as well.

The system will be able to control the brake pedal if the operator fails to hit the brake when required. Ultimately it will ensure the safety.

Also, it will display the vehicle operating parameters such that faults can be minimized and eliminated. Also, it will help finding out the probable faults by analyzing the parameters.

The objectives are achieved by using the components as per the Table 1.

TABLE 1 Components and its purposes

Components	Purpose
Hall Sensor (A3144) sensors	To measure RPM Temperature DHT11
Sound Buzzer	To measure temperature For Emergency alarms
Micro-controller (ESP8266 node MCU) and Arduino	Data processing and Sending data to the internet and controlling the brake actuator
Ultrasonic Sensor	To detect any obstacle
Brake pedal	To demonstrate the braking
DC gear motor and motordriver	To actuate the brake pedal
12 V DC source	To provide Power to the Motor and Voltage Regulator
7805 voltage regulators	To convert 12 volts to 5 volts to power sensors and Arduino also

3. Working

The components were connected as per the circuit diagram (Figure1). Then suitable coding was done on the microcontroller was the proper operation.

Ultrasonic sensors are being used for the automatic braking system. It sends out a signal that pings off objects in front of it to determine distance. It can see up to maximum of 4 m in front of the car, but it can't tell what it's seeing. So far, this is just how your car knows that there's an obstacle in front of you.

So now your car has determined that you're about to hit the obstacle. It will first give you alert. Then it can also sense that you're not doing a thing about it. You're not jamming on the brake. It's time for your car to take things into its own hands.

So, it will first check the velocity of the car using the hall sensor, in present model it is not incorporated, due to constraints. If driver slows down the car or the speed is slowed down to the safety speed, then no actions will be taken.

But if the speed is still high, then it will check for the status of the brakes by taking the potentiometer value attached in the brakes as the input, in present model it is not incorporated, due to constraints. If the potentiometer value/voltage value is changed means the driver already applied the brakes, then no actions will be taken. But if the brakes are not applied then it will send signal to the DCGEAR motors to pull the brakes. Also, a signal will be sent to the Buzzer/horn to alarm the driver. This way it can prevent the accident and ensure safety.

DHT 11 sensors are being used for monitoring the temperature of engine oil. The engines are designed in such a way that the oil temperature should be in the range of 90°C to 100°C. By Ink and Node MCU were used for data acquisition.

The functioning of voltage regulator and motor driver is explained above, the motor driver is used to power the motor whenever there is a signal from the Arduino, the motor driver finds useful because Arduino cannot power the required output with 5 volts so we need an extra source. Similarly, the sensors used require 5 volt each, which is not possible to power all of them with Arduino, so voltage regulator IC 7805 is used.

The functioning of hall sensor is mentioned above to measure the RPM, here in our system, we have used a fan as wheel onto which a is mounted a magnet. The hall sensor will be placed such that to maintain the line of sight with magnet. So, for 10 rotation time will be noted, and RPM will be calculated using the formulae,

$$\text{RPM} = 10 * 1000 / (\text{time} * 60).$$

Here the time noted is in milli second.

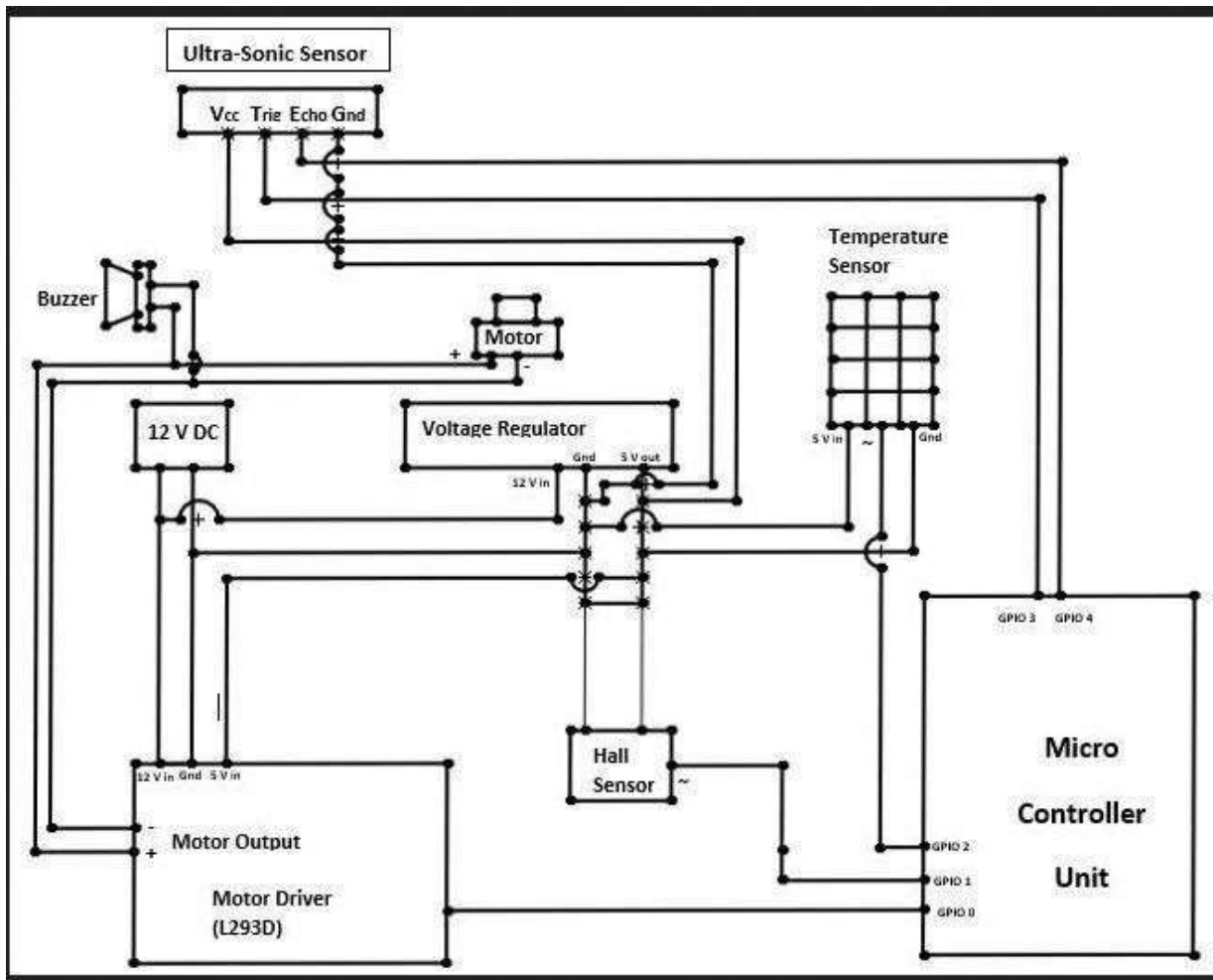

Figure 1 Circuit Diagram

4. Conclusion and future scope

The proposed system has been developed to prevent the fault before it occurs by tracking the features incorporated within it. Also, the system is useful in diagnosing the fault. It will ease the mechanic work because the probable cause can be determined if the breakdown occurs due to inadequate RPM or inadequate temperature. Apart from it, having an automatic braking system incorporated within it ensures the occupant safety and prevents accidents.

In this present project we have used the Bylnk app, due to which many constraints are there: instant update of the real-time data is not allowed, update happens in few seconds, app visuals are not user-friendly, notification did not work when app is closed. So, in the future, a new application can be developed by eliminating the above-stated problems. One special feature of the app will be parental control, where a guardian can check and limit the speed of the vehicle.

The number of sensors used are DHT (to measure temperature), hall (to measure RPM) and ultrasonic (to detect obstacle). To improve further, sensors like a potentiometer (to check brake, accelerator, clutch pedal functionality), flame sensor (to detect fire), strain gauge (to check suspension working), GPS (to locate location) can be used.

The design of pedals can be improved and embedded with actuator to maintain robustness, compactness and usability. It could be done using gear assembly and using a special made actuator according to the need.

References

- [1] Alonso, L., Pérez-Oria, J., Fernández, M., Rodríguez, C., Arce, J., Ibarra, M. and Ordoñez, V., 2010, September. Genetically tuned controller of an adaptive cruise control for urban traffic based on ultrasounds. In *International Conference on Artificial Neural Networks* (pp. 479-485). Springer, Berlin, Heidelberg.
- [2] Alonso, L., Milanés, V., Torre-Ferrero, C., Godoy, J., Oria, J.P. and De Pedro, T., 2011. Ultrasonic sensors in urban traffic driving aid systems. *Sensors*, 11(1), pp.661-673.
- [3] Primadi, U.R., Prasetya, D.A. and Eng, S.T.M., 2019. *Sistem Monitoring RPM Motor Listrik Melalui Perangkat Telepon Pintar Berbasis IoT* (Doctoral dissertation, Universitas Muhammadiyah Surakarta).
- [4] John Turner. *Automotive Sensors*. Momentum Press. 2009
- [5] John Vetelino, Aravind Reghu. *Introduction to Sensors*. Taylor and Francis. 2017
- [6] Marco Schwartz. *Internet of Things with ESP8266*. Packt Publisher. 2016
- [7] Upskill Learning. *ESP8266: Get Started with ESP8266 Programming Node MCU Using Arduino IDE*. 2016
- [8] Yongzhe Kang, et. al. *Online multi-fault detection and diagnosis for battery packs in electric vehicles*. J. Applied Energy. 2019
- [9] Xia B, et. al. *A correlation based fault detection method for short circuits in battery packs*. J. Power Sources. 2017
- [10] Zhang J, Lee J. *A review on prognostics and health monitoring of Li-ion battery*. J Power, 2011